



# केंद्रीय भंडारण निगम

(भारत सरकार का एक उपक्रम)

CENTRAL WAREHOUSING CORPORATION

(A Govt. of India Undertaking)

**TENDER NO: 10T/20-21**  
**(E- Tendering Mode Only)**

**FOR**

Name of Work: “Major repairs and strengthening to Gable walls of Godown No. 2A to avoid differential settlement and remedial measures including Piling at CW Gadag-II,( Karnataka)”

**CENTRAL WAREHOUSING CORPORATION,  
REGIONAL OFFICE, BANGALORE  
SUPERINTENDING ENGINEER**

**Address: LF-10, 4th Cross Road, Saraswathipuram,  
Nandini Layout, Bangalore-Pin -560096.**

**PH No.: 080-23598861; 23598866; 23598863**

**Email ID: [engg.blrcwc@cewacor.nic.in](mailto:engg.blrcwc@cewacor.nic.in) ;  
[rmlr@cewacor.nic.in](mailto:rmlr@cewacor.nic.in)**

**Website- [www.cewacor.nic.in](http://www.cewacor.nic.in)**

Corporate Office, 4/1, Siri Institutional Area, August Kranti Marg, Hauz Khas, New Delhi

**Abbreviation of the words used in Tender document**

NIT	=	Notice Inviting Tender
CWC	=	Central Warehousing Corporation
CPWD	=	Central Public Works Department
MES	=	Military Engineering Services
PWD	=	Public Works Department
PSU	=	Public Sector Undertaking
EMD	=	Earnest Money Deposit
CPP	=	Central Procurement Portal
PF	=	Provident Fund
SD	=	Security Deposit
LD	=	Liquidated damage
GCC	=	General Condition of Contract
BIS	=	Bureau of Indian Standard
IRC	=	Indian Roads Congress
CTE	=	Chief Technical Examiner
MORTH	=	Ministry of Road Transport & Highway
DSR	=	Delhi Schedule of Rates
SOR	=	Schedules of Rates
PERT	=	Programme Evaluation Review Technique.
MD	=	Managing Director
ICD	=	Inland Container Depot
OCY	=	Open Container Yard
BG	=	Bank Guarantee
FD/FDR	=	Fixed Deposit Receipt
IPC	=	Indian Penal Code
PC	=	Prevention of Corruption
EOT	=	Extension of Time
OPC	=	Ordinary Portland Cement
PPC	=	Pazzolana Portland Cement
RMC	=	Ready Mixed Concrete
IIT	=	Indian Institute of Technology
T&P	=	Tools & Plants
CAR Policy	=	Contractor's all Risk Policy
WC Policy	=	Workmen Compensation Policy
ESI	=	Employees State Insurance
PQ	=	Pre Qualifying
GST	=	Goods and Services Tax
CGST	=	Central Goods and Services tax
SGST	=	State Goods and Services tax/
IGST	=	Integrated Goods and Services tax
UGST	=	Union Territory Goods and Services tax
LAR	=	Last Approved Rates
PQC	=	Pavement Quality Concrete
WBM	=	Water Bound Macadam
WMM	=	Wet Mix Macadam
DBM	=	Dense Bituminous Macadam
DPC	=	Damp Proof Course
CC	=	Cement Concrete
RCC	=	Reinforced Cement Concrete
DLC	=	Dry Lean Concrete
MT	=	Metric Tonne



## CENTRAL WAREHOUSING CORPORATION

(A Govt. of India Undertaking)

### Regional Office-Bangalore

LF-10, 4<sup>th</sup> Cross Road, Saraswathipuram, Nandini Layout, Pin -560096

NO.CWC/RO-BLR/Engg /NIT/20-21/10

Date: 25-02-2021

### PRESS NOTICE INVITING E- TENDER NO.10T/20-21

CWC invites online tender from the contractors for the following work: -

Sr. No	Name of Work	Estimated Cost in Rs.	Last date of online Submission of tender
1	Major repairs and strengthening to Gable walls of Godown No. 2A to avoid differential settlement and remedial measures including Piling at CW Gadag-II,( Karnataka)	35,87,578/-	11.03-2021

Detailed Tender Notice along with conditions of contract and Notice Inviting E-Tender may be seen and downloaded from the CWC website [www.cewacor.nic.in](http://www.cewacor.nic.in) or e-tender website [www.cwceprocure.com](http://www.cwceprocure.com) or CPP Portal <http://eprocure.gov.in/epublish/app>. Further Corrigendum/Addendum to this Tender, if any, will be published on these websites only and any press advertisement in newspapers shall not be issued for the same.

**SUPERINTENDING ENGINEER**

# CENTRAL WAREHOUSING CORPORATION

(A Govt. of India Undertaking)

## Regional Office-Bangalore

LF-10, 4<sup>th</sup> Cross Road, Saraswathipuram, Nandini Layout, Pin -560096

NO.CWC/RO-BLR/Engg /NIT/20-21/10

Date:25-02-2021

### NOTICE INVITING TENDER NO. 10T/20-21

#### (E-tendering mode only)

Online percentage rate E-tender in two bid system is invited for the below mentioned works from Contractors of appropriate class of CPWD/Railways/MES/State PWD/other Government Organization/ Public Sector Undertakings & their Subsidiaries or having worked/ working with aforesaid Government Departments/ Agencies: -

Tender No.	10T/20-21
Name of Work	Major repairs and strengthening to Gable walls of Godown No. 2A to avoid differential settlement and remedial measures including Piling at CW Gadag-II,( Karnataka)
Estimated cost put to tender	Rs. <b>35,87,578/-</b> (Rupees Thirty five Lakh eighty seven thousand five hundred seventy eight Only)
Earnest Money	Rs. 71,800/-( Rupees Seventy one thousand eight hundred Only)
Cost of tender document (Non-refundable)	Rs. 590/- including GST
Time Allowed for completion of work	<b>3.0</b> Months from the date of Start as defined in Letter of Acceptance (LOA).
Tendering Processing Fee (Non-refundable)	Rs. 885/-including GST
Last date & time of submission of cost of tender & e-tender processing fee and downloading of tender document (tech. & price bid)	10/03/2021up to 15:00 Hrs.
Last date & time of submission of Tender & EMD	11/03/2021up to 15:00 Hrs.
Date & time of opening of Technical Bid	11/03/2021at 15:30 Hrs.
Date & Time of opening of Financial Bid	Date of opening will be intimated separately for technically qualified Tenderers.

Tender documents including contract conditions and schedule of work may be down loaded by the intending contractors, who wish to participate, from **CWC website [www.cewacor.nic.in](http://www.cewacor.nic.in) or e-tender website [www.cwceprocure.com](http://www.cwceprocure.com) or CPP Portal <http://eprocure.gov.in/epublish/app>.**

## **ELIGIBILITY CRITERIA:**

Contractor who fulfils the following requirements shall be *eligible to quote the rates*.

### **A) Mandatory Documents**

#### **1. EMD, Cost of Tender & Tender Processing Fees:**

Contractor must submit the following:

- a. The EMD to be paid in favour of **Central Warehousing Corporation, New Delhi only through e-payment gateway of e-procurement** and receipt of the same should be scanned and uploaded on the e-tendering website [www.cwceprocure.com](http://www.cwceprocure.com) along with e-tender documents.
- b. Cost of tender to be paid **only through e-payment gateway of e-procurement system. Proof to be submitted/uploaded with the tender.**
- c. Tender processing fee (Non- refundable) would be paid mandatorily to M/s ITI Ltd. through e-payment through the portal [www.cwceprocure.com](http://www.cwceprocure.com).

#### **2. EXPERIENCE CERTIFICATE:**

Tenderer should have completed successfully at least one similar nature of work " (i.e **Any Civil Works including cement concrete works, RCC Works, Piling works OR Masonry works or Finishing works OR road works OR Any Civil Works including cement concrete works, RCC Works, Piling works OR Masonry works or Finishing works OR road works OR Construction of Godowns or Industrial sheds or Building Works along with associated works of drain, road , circulating area**)" of value not less than Rs.**12.56 Lakhs**(Rupees Twelve lakh fifty six thousand)(35% of the advertised Estimated Cost) during the last **four** financial years (i.e. 2016-17, 2017-18, 2018-19 & 2019-20) and current Fy. Year 2020-21 up to the date of tender submission. Certificate should include the name of work, agreement number, date of start, actual date of completion & gross amount of work done up to the completion.

**Note:**

- (1) It should be noted that credentials for the works executed for Private Organisations shall not be considered.**

#### **3. TURNOVER:**

The sum total (arithmetic sum) of tenderer's turnover/ revenue (income) from operations for the last three financial years (i.e.2017-18, 2018-19& 2019-20) should be of value not less than Rs. **32.29Lakhs (Rupees Thirty Two Lakhs twenty nine thousand) ;(90% of advertised Estimated Cost)**. The information shall be supported by CA certificate & audited Balance Sheets and of Profit & Loss Statements of specified last three financial years. In case Balance Sheet and Statement of Profit & Loss for the immediate preceding financial year have not been prepared/audited, the account for one more preceding financial year can be submitted.

4. Tenderer shall also submit an Affidavit duly attested by Notary as per **ANNEXURE\_IV** certifying that the documents submitted along with the tender are under his knowledge and are authentic, genuine, copy of their originals and no part of them is false, forged or fabricated.

**NOTE - Tenderer not fulfilling the above requirement of mandatory documents or submission of clarification with respect to mandatory documents, shall be summarily rejected.**

**B) Other Documents**

5. **PRE-CONTRACT INTEGRITY PACT:**  
Tenderer will have to sign the pre-contract integrity pact as per the enclosed proforma at **ANNEXURE\_V** for contracts having estimated value of **Rs. 2.00 crore or more and duly signed copy has to be submitted with the tender.**
6. **NET WORTH:**  
Tenderer should submit positive net worth certificate duly certified by a practising Chartered Account as per **ANNEXURE\_I** based on the latest financial year for which accounts i.e. Profit & Loss Account and Balance Sheet has to be enclosed with the tender.
7. **GST Registration:**  
Contractor must have valid GST registration certificate from the concerned authority (as applicable) and copy to be enclosed with the tender.
8. **PAN Card:**  
Tenderer must enclose copy of PAN card along with the tender.
9. **PF Registration:**  
Tenderers must have valid PF Registration certificate from the concerned authority and copy to be enclosed with the tender.
10. **ORGANISATION DETAILS:**  
In case the Tenderer is a proprietorship firm, they will submit an affidavit as per **ANNEXURE\_II**  
In case the Tenderer is a partnership firm, a certified copy of the partnership deed shall be submitted by the Tenderer.  
In case the Tenderer is a company (whether Private or public), a certified copy of Certificate of Incorporation together with Memorandum and Article of Association shall be submitted).  
Certificate of Registration with Registrars of Company (ROC) in case of Ltd. / Pvt. Ltd. company/PSU, if required shall be submitted by the Tenderer.  
In other cases, certified copy of Certificate of Incorporation shall be submitted by the Tenderer.
11. Tenderer shall submit a Power of Attorney in favour of signatory(ies) duly attested by the notary as per **ANNEXURE\_III**. This format is for the purpose of guidance only and deviation in the wording can be accepted.

**12. COMPLIANCE TO BID REQUIREMENT**

Tenderer shall submit a declaration as per **Annexure-VI** with the technical bid confirming that he/she/they has understood the tender documents and his/ her/ their bid complies with the tender requirements / terms & conditions of the tender documents, he/she/they has/have quoted the rates without any condition and deviation and the rates quoted are as per the tender documents.

**13. A Bar chart/ PERT network indicating various milestones and date of completion vis-a-vis deployment of resources to be enclosed with the tender.**

**14.** Form of Declaration to be given by the bidder as per format along with tender on non-judicial stamp paper of minimum value of Rs. 100/- (**Annexure-IX**).

**15.** Technical bids would be opened **at 3.30 p.m. on 11/03/2021** and the same would be examined by the committee of the CWC officers. In the event of any of the documents found fabricated/ tempered/ forged/ altered/ manipulated/ false during the evaluation of bid at any stage, it will lead to rejection of the bid and forfeiture of EMD of the tenderer. CWC reserve its rights to disqualify the tenderer and to blacklist/ debar for future participation for the next five years.

In the event of any of the documents found fabricated/ tempered/ forged/ altered/ manipulated/ false in the bid even after the award of the contract, it will lead to termination of the contract, forfeiture of EMD or Performance Security/ Security Deposit whichever is available at the time of termination. CWC reserve its rights to disqualify the tenderer and to blacklist/ debar for future participation for the next five years.

**16.** In case the contractor fails to submit the requisite Performance Guarantee even after the period specified in Clause 1 of Schedule 'F' from the date of issue of letter of acceptance (LOA) , the contract shall be terminated duly forfeiting EMD and other dues, if any payable against the contract. The failed contractor shall be debarred from participating in re-tender for that work.

**17. Date of opening of Financial bids shall be intimated later on.**

**18.** Tenderers or their authorized representative who may wish to be present, may attend the opening of the technical bids whereas financial bids by only those who are found eligible in technical bids.

**19.** Corrigendum/Addendum to this Tender, if any, will be published on website [www.cewacor.nic.in](http://www.cewacor.nic.in), [www.cwceprocure.com](http://www.cwceprocure.com) and Central Procurement Portal (CPP) <http://eprocure.gov.in/epublish/app> only. Newspaper press advertisement shall not be issued for the same.

**20.** It is works contract. There is no EMD & Tender cost exemption to MSME bidders.

**21. Tenderer / bidder shall quote their rate inclusive of GST, ESI, EPF, Building & construction workers cess and any other taxes, levies, duties as applicable on complete work, after study the relevant clauses. CWC will not entertain any claim what so ever in this respect. This should be included in the rates quoted by contractor.**

22. For any difficulty in downloading & submission of tender documents please contact: -

M/s Indian Telephonic Industries Limited,  
C-62, 2<sup>nd</sup> Floor, Preet Vihar, Opp. To Metro pillar 79,  
New Delhi-110092

**May call following help line numbers at 011-49424365/0-8800115946**

23. **Address of Site of work and its brief is as below.**

Site of work	CW-Gadag Unit II, Karnataka
Address of Site of work	Central Warehousing Corporation, KIADB Industrial Area, Narsapur Gadag-582102
Nearby Major Railway Stations.	Gadag Junction
Nearest City/District	Gadag.
Nearest Airport	Hubbali Airport

**SUPERINTENDING ENGINEER**



# Index

SN	SECTION	CONTENT	Ref: Page No.
1.		CHECK LIST TO BE FILLED BY BIDDER & SUBMITTED ALONGWITH THE TENDER	10-11
2.		PQ PERFORMA TO BE FILLED BY BIDDER & SUBMITTED ALONGWITH TENDER.	12-13
3.	Section-I	INSTRUCTIONS TO TENDERERS	14-24
4.	Section-II	MINIMUM CRITERIA FOR ELIGIBILITY OF THE TENDERERS	25-26
5.	Section-III	SPECIAL CONDITIONS OF CONTRACT	27-41
6.	Section-IV	TENDER FORMS & ANNEXURES	42-60
7.	Section-V	GENERAL CONDITIONS OF CONTRACT (CPWD Conditions of Contract)	61-152
8.	Section-VI	Directives of Hon'ble National Green Tribunal	153-154
9.	Section-VII	Model Rules for the Protection of Health and Sanitary Arrangements for Workers	155-161
10.	Section-VIII	C.P.W.D. Contractor's Labour Regulations	162-192
11.	Section-IX	OPERATIVE SCHEDULES	193-201
12.	Section-X	TECHNICAL CONDITIONS/SPECIFICATIONS	202-215
13.	Section-XI	WORK REGISTER AND TESTING PROFORMAS	216-235
14.	Section-XII	LIST OF MANDATORY TESTS	236-244
15		Schedule of quantities	245-250
16		Price Bid Format	251
17		Technical Drawings (Building Plan & Elevation)	



**CENTRAL WAREHOUSING CORPORATION**  
(A Govt. of India Undertaking)

**CHECK LIST TO BE FILLED BY BIDDER & SUBMITTED ALONGWITH THE TENDER**

SL. No.	Documents to be submitted by the tenderer along with their bid	Check & confirm of having attached these documents along with Bid (Yes/No)	
1.	Earnest Money Deposit (EMD): <b>only through e-payment gateway of e-procurement system.</b>		
2.	Proof of tender cost paid <b>only through e-payment gateway of e-procurement system</b>		
3.	Experience Certificate FOR EXECUTING WORKS of similar nature as per tender eligibility criteria issued by Government organisations.		
4.	Chartered Accountant Certificate certifying his Annual Turnover and complete audited balance sheet and statement of Profit & Loss for preceding three financial years.		
5.	Affidavit on stamp paper duly attested by the notary as per <b>ANNEXURE_IV</b>		
6.	Pre-Contract Integrity Pact as per <b>ANNEXURE_V</b> duly signed by tenderer.		
7.	Certificate of Net Worth duly certified by the Chartered Accountant as per <b>ANNEXURE_I.</b>		
8.	GST registration Certificate (as applicable).		
9.	Permanent Account Number (PAN) Card.		
10.	PF Registration certificate.		

11.	a) Affidavit for sole proprietary firm as per <b>ANNEXURE_II</b> or b) Copy of Partnership deed of a partnership firm or c) Certificate of Incorporation, Memorandum of Association & Articles of Association for company along with resolution of the company for authorizing the Director/ authorised signatory to sign the document.		
12.	Certificate of Registration with Registrars of Company (ROC). in case of Ltd. / Pvt. Ltd. company/PSU, if required.		
13.	Power of Attorney in favour of signatory (ies) duly attested by notary as per <b>ANNEXURE_III</b> , if required.		
14.	Compliance to Bid requirement as per Annexure-VI.		
15.	Bar Chart duly signed.		
16.	Affidavit by the tenderer as per <b>ANNEXURE_IX</b> .		
17.	Valid Contractor Registration Certificates or Proof of having worked/ working with CPWD/Railways/MES/State PWD/other Govt. Organization/ Govt. Sector Construction Agency/Public Sector Undertaking& their Subsidiary.		
18.	List of permanent technical persons.		
19.	List of Plant & Machinery.		
20.	Pre-Qualifying (PQ) Proforma.		
21.	Bank Details (Account No., Bank Name, MICR No, RTGS No. & copy of cancelled cheque).		
22.	Electrical license, if required.		
23.	Submission of complete tender document, duly signed.		

## Pre-Qualifying (PQ)-Proforma/Comparative Statement

**(To be filled by bidder and submitted along with tender document)**

<b>Name of Work: Major repairs and strengthening to Gable walls of Godown No. 2A to avoid differential settlement and remedial measures including Piling at CW Gadag-II,( Karnataka)</b>		
<b>Tender No: 10T/20-21</b>		<b>DATE- 25/02/2021</b>
<b>NAME OF THE FIRM :.....</b>		
S. No.	Description	Details
1.	Name, Address, Organization ID, Tel. / Fax No. & e-mail address of Bidder	
2.	Attested copy of Firm Details (Proprietorship/Partnership/private limited / limited )	
3.	Attested Copy of Power of Attorney details to sign the Tender Document.	
4.	Earnest Money Deposit (EMD) of <b>Rs.71,800/- only through e-payment gateway of e-procurement system.</b>	
5.	Cost of Tender Documents of <b>Rs. 590/-only through e-payment gateway of e-procurement system</b>	
6.	PF Registration.	
7.	GST Registration (as applicable)	
8.	PAN No. of the firm	
9.	Contractor Registration	
10.	Chartered Accountant's (CA) Certificate for Annual financial turnover/revenue (income) from operations of specified preceding three years.	
11.	Annual Financial turnover/revenue (income) from operations (as per P&L Account)	
	a) FY-2017-18	
	b) FY-2018-19	
	c) FY-2019-20	
12.	<b>Financial Eligibility Criteria: -</b> The sum total (arithmetic sum) of tenderer's turnover/ revenue (income) from operations for the last three financial years ( <b>i.e2017-18, 2018-19&amp; 2019-20</b> ) should be of value not less than <b>Rs.32.29 LAKHS (90% of advertised Estimated Cost)</b> the information shall be supported by CA certificate & audited Balance Sheets and of Profit & Loss Statements of specified last three financial years. In case Balance Sheet and Statement of Profit & Loss for the	

	immediate preceding financial year have not been prepared/audited, the account for one more preceding financial year can be submitted. Please see NIT condition no, 3 of eligibility Criteria's	
13.	<b>Experience with respect to similar nature of work: -</b>  Tenderer should have completed successfully at least one similar nature of work.i.e“ <b>Any Civil Works including cement concrete works, RCC Works, Piling works OR Masonry works or Finishing works OR road works OR Construction of Godowns or Industrial sheds or Building Works along with associated works of drain, road , circulating area</b> ” of value not less than Rs.12.56 Lakhs(35% of the advertised Estimated Cost)duringthe preceding <b>four</b> financial years ( <b>i.e 2016-17, 2017-18 , 2018-19&amp; 2019-20) &amp; current year (2020-21)</b> up to the date of tender submission. Certificate should include the name of work, agreement no., date of start, actual date of completion & gross amount of work done up to the completion.	
13 A	<b>NOTE: (1) It should be noted that credentials for the works executed for Private Organisations shall not be considered.</b>	
14.	Bar Chart	
15.	Pre-Contract Integrity Pact as per <b>ANNEXURE_V</b> duly signed by tenderer.	
16.	Compliance to Bid requirement as per Annexure-VI.	
17.	Bank Detail i.e. Cancelled Cheque, Name of Bank, Account Number, MICR No., RTGS No., Bank Telephone	
18.	Affidavit ( <b>ANNEXURE_IV</b> ) to be submitted by the bidder as per format along with tender.	
19.	Affidavit ( <b>ANNEXURE_IX</b> ) to be submitted with tender.	
20.	Certificate of Net Worth duly certified by the Chartered Accountant as per <b>ANNEXURE_I</b> .	
21.	Details of any other information	
Note: 1:- Tenderers have to fill the complete details in Pre-Qualifying Proforma.		
Note: 2. The documents pertaining to above details should be scanned and uploaded in the e-tendering website at the time of online tender submission.		
Note: 3. RTGS/ NEFT E-payment Challans with UTR no. <u>duly authenticated by Bank</u> may also be scanned & uploaded along with tender submission.		
Note: 4. Affidavit ( <b>ANNEXURE_IV</b> ) must be submitted by the bidder.		

**Tenderer: Please see clause- 1,5,28,29,30,31,40 & 53 of 'Instructions to Tenderers'.**

**SECTION – I**  
**(INSTRUCTIONS TO TENDERERS)**



## CENTRAL WAREHOUSING CORPORATION

(A GOVT. OF INDIA UNDERTAKING)

---

Regional Office- LF-10, 4<sup>th</sup> Cross Road, Saraswathipuram, Nandini Layout, Pin -560096.

Corporate Office, 4/1 Siri Institutional Area, August Kranti Marg, Hauz Khas, New Delhi

---

### INSTRUCTIONS TO TENDERERS

**Online percentage rate E-tenders are invited on behalf of Central Warehousing Corporation for:**  
“Major repairs and strengthening to Gable walls of Godown No. 2A to avoid differential settlement and remedial measures including Piling at CW Gadag-II,( Karnataka)”

1. Tenderer should upload all the required documents with the tender under valid digital signature. Uploading of tender with digital signature shall imply that all tender terms & conditions are accepted by the tenderer.
2. Tenderer digital signature on the E- Tender form will be considered as their confirmation that they have read and accepted all the conditions laid down in the tender documents, unless specific deviation is quoted in the technical bid.
3. E- Tender form is not transferrable and the same is to be submitted with digital signature/ signed & scanned copy by the pre- authorized personnel of the tenderer. Tender is to be submitted through e-tender-mode only at website [www.cwceprocure.com](http://www.cwceprocure.com) along with scanned copies of credential papers.
4. For whatsoever reasons, if any part of CWC tender document is not uploaded/submitted by the Tenderer, other than financial and technical offers and requisite Pre-Qualifying credentials, in that case the missing part of the tender document shall be treated as read and acceptable to Tenderer. **Missing part of CWC tender document shall not be called for re-submission, however, the same shall form part of contract agreement and shall be binding on Tenderer.**
5. **The tender without the prescribed earnest money, shall be summarily rejected.**
6. Any request for recovery from outstanding bills for earnest money against present tender will not under any circumstances be entertained. Tenders submitted with earnest money in the forms other than specified in NIT shall not be considered.
7. No interest shall be allowed on the Earnest Money.
8. Earnest money of the unqualified Tenderers shall be released after finalization of Technical bid in case of Two Bid System of tendering. EMD of technically qualified but unsuccessful Tenderer will be refunded after the award of Tender. EMD of unsuccessful Tenderers shall be released after finalization of tender in case of Single Bid System of tendering. The Tenderer is advised to provide name of bank, account number, branch code and RTGS code for account maintained by them/him for any financial transaction,

if found necessary.

9. For the successful Tenderer, earnest money will be retained as part of the security deposit in terms of **CLAUSES OF CONTRACT**. The earnest money of other Tenderers shall, save as herein before provided, be returned to them, but CWC shall not be responsible for any loss or depreciation that may happen thereto while in their possession, nor be liable to pay any interest thereon.
10. The Tender notice and Notice Inviting Tender shall form the part of contract document. The successful Tenderer/s shall be required to execute an agreement with CWC in prescribed Proforma at ANNEXURE VII within a maximum period of 15 days after date of issue of Work Order for carrying out the work as per the agreed conditions. **Failure to do so shall constitute a breach, in which case, CWC would be at liberty to not only terminate the contract but also forfeit EMD and Performance Guarantee if any.** The cost of stamp paper for the agreement will be borne by contractor. The contract agreement shall consist of:

The Press Notification, Tender Notice, Notice Inviting Tender, Instructions to Tenderers, all the documents of tender & contract for works including special conditions of contract, technical specifications and drawings, if any, forming the part of tender documents as issued/ downloaded by the Tenderer from the websites at the time of invitation of tender and acceptance thereof together with any correspondence with them leading there to and also the correspondence related with verification of credentials.

11. The contract operations and proceeding in connection with the works at all times be conducted during the continuance of contract in accordance with the laws, ordinances, rules and regulations for the time being in force and the contractors shall further observe and comply with the bylaws & regulations of the Government of India, State Government, local Municipalities and other authorities having jurisdiction over area involved in connection with the works of site & over operations such as those as carried out by the contractor/s and shall give all notices required by such by-laws & regulations. The hospital and medical regulations in force for the time being shall also be complied with by the contractor/ contractors and his workmen.
12. The contractor shall be responsible for the observance of the rules and regulations under the Mines Act and Mineral Rules and Indian Metallurgical rules and regulations of State Government concerned as amended from time to time.
13. The contractor shall at all times keep the CWC indemnified against all penalties that may be imposed by the Government of India or State Government for infringement of any other clauses of the mines act and rules made there under in respect of the quarries from which the quarry material for these works is procured.
14. The Tenderer/s shall not increase his/their rate in case CWC negotiates for reduction of rates. Such negotiations shall not amount to cancellation or withdrawal of original offer and rates originally quoted will be binding on the Tenderer/s.



15. The Tenderer/s shall submit an analysis of rates, if called upon to do so.
16. Contractor is required to get himself registered as per Building & Other Construction Workers Cess Act 1996, PF Registration, Goods and Service Tax, etc, as per Govt. of India law.
17. Time is the essence of the contract. In order to complete the work within the scheduled time, the Tenderer is required to submit copy of GST registration certificate, PAN Card, a PERT/ BAR CHART for major mile stones for various activities indicating the time required for the same along with tender documents /Performance Guarantee.
18. Copies of the drawing and documents pertaining to the works will be open for inspection by the Tenderers in the office of the Superintending Engineer RO Bangalore.
19. Tenderers are advised to inspect and examine the site and its surroundings and satisfy themselves before submitting their tenders as to the nature of ground and sub-soil (so far as is practicable), the form and nature of the site, the means of access to the site, the accommodation they may require and in general shall themselves obtain all necessary information as to risks, contingencies and other circumstances which may influence or affect their tender. In case of hindrances, if any, because of telephone line, electric cables, overhead lines etc. passing over the site, the contractor shall be entitled for extension of time under clause 5 of the agreement (GCC). No claim of extra payment and damages of any sort shall be entertained on this account. A Tenderer shall be deemed to have full knowledge of the site whether he/ they inspects it or not and no extra charges consequent on any misunderstanding or otherwise shall be allowed. The Tenderer shall be responsible for arranging and maintaining at his own cost, all materials, tools and plants, water, electricity access, facilities for workers and all other services required for executing the work unless otherwise specifically provided for, in the contract documents. Submission of a tender by a Tenderer implies that he has read this notice and all other contract documents and has made himself aware of the scope and specifications of the work to be done and of conditions and rates at which stores, tools and plants etc. will be issued (if any) to him by the Corporation and local conditions and other factors having a bearing on the execution of the work.
20. The Competent Authority on behalf of Central Warehousing Corporation does not bind himself to accept the lowest or any other tender and reserves to himself the authority to reject any or all the tenders received without the assignment of any reason. All tenders in which any of the prescribed condition is not fulfilled and any condition including that of conditional rebate is put forth by the Tenderer shall be summarily rejected.
21. The Competent Authority on behalf of Central Warehousing Corporation does not bind himself to accept the lowest tender and reserves to himself the right of accepting the whole or any part of the tender and the Tenderer shall be bound to perform the same at the rate quoted.

22. Tenders containing any condition leading to unknown/indefinite liabilities shall be summarily rejected.
23. Canvassing whether directly or indirectly in connection with tenders is strictly prohibited and the tenders submitted by the contractors who resort to canvassing will be liable to rejection.
24. In the financial bid the prices/ rates must be filled after downloading the financial bid document in the prescribed format issued through online e-tendering website. The financial bid should be saved and duly filled up and uploaded to the e-tendering site using **digital signatures** for signing the documents/ (signed and uploaded).
25. On acceptance of the tender, the name of the accredited representative(s) of the contractor who would be responsible for taking instructions from the Engineer-in-charge / Engineer shall be communicated to the Engineer-in-Charge.
26. Under Income Tax Act, 1961, a deduction for income tax along with surcharge as applicable will be made from sums paid on account and final payments for carrying out the work under this contract.
27. The Tenderer shall be required to pay cess @ 1% of cost of construction work in accordance with each bill payable on account of such construction to the **concerned State Govt. (Labour Deptt.)**. Cost of material shall be outside the purview of cess, when supplied under a separate schedule items. CWC shall not entertain any claim whatsoever in this respect.
28. The tenderer shall scan and upload the proof of submission of EMD, Cost of tender, CA Certificate & balance sheets with Profit & Loss account of specified preceding three financial years in respect of financial turnover, Power of Attorney, Affidavit of Proprietorship/Memorandum & Article of Association, PF Registration Certificate, Pan card, Bar chart, Goods and Service Tax Registration Certificate, similar nature works completion certificates, Annexure-IV, Net Worth certificate, Pre-contract integrity Pact if required, Annexure-VI and Annexure-IX.
29. **No additional mandatory documents will be entertained after tender opening, except clarification documents required if any, regarding already submitted documents with tender. Any documents submitted suomoto by the Tenderer through e-mail/ post/ hand delivery, etc, shall neither be entertained nor considered for evaluation.**
30. **For deciding eligibility of tender, it is mandatory for Tenderer to submit Affidavit (as per ANNEXURE IV), EMD, Financial Turnover (Balance Sheets with Profit & Loss Account of specified preceding three years as per NIT) and Similar nature of work experience certificates of requisite magnitude (as per NIT) failing which the tender shall be summarily rejected.**
31. **All other documents like Pre-Contract Integrity Pact, Net Worth, Goods and Services Tax Registration Certificate, PAN Card, PF Registration, Organisation details, Power of Attorney, Annexure VI, Bar/PERT Chart, Form of declaration as per format Annexure IX, List of plant & machinery, list of permanent technical persons, Bank details etc. as per NIT/pre-qualifying Proforma/ comparative statement, are also required to be**

submitted along with tender.

**NOTE:** (a) CWC (Corporation), if necessary, can ask the tenderer for any specific clarification relating to qualifying documents/conditions within the specified time of 07 days. For this purpose, the procedure stated below is to be followed and the specific clarification is required to be uploaded on the same portal as per the procedure prescribed therein.

(b) The tenderer has the option to respond or not to respond to these queries.

(c) The request for clarification by the Corporation and the response of the tenderer shall be in writing and no change in price or substance of the tender shall be sought, offered or permitted.

(d) If the tenderer fails to respond, within the stipulated time period or the clarification(s)/document (s) with respect to mandatory documents submitted is non-conforming to requirement of tender conditions, no further time will be given for submitting the same and the tender will be summarily rejected.

(e) All other documents should also be uploaded by the tenderer. However, if the tenderer has not uploaded any of the other documents as per NIT/pre-qualifying Proforma/ comparative statement, lowest tenderer should submit the same with submission of Performance Guarantee, If the lowest tenderer fails to do so than no Agreement in between CWC and contractor will be executed and it will lead to rejection of bid and forfeiture of EMD & Performance Guarantee.

For obtaining clarification, following procedure is to be followed:

(i) An icon for clarification shall appear on “Bid details” page (in front of each of the tenderer’s name) at Corporation’s end after opening of Technical /Financial Bid.

(ii) Corporation shall click on clarification icon for the desired tenderer and enter the details of clarifications sought within the prescribed time.

(iii) After entering the details of clarification sought by the Corporation, same icon shall appear at tenderer’s end for replying to the particular clarification sought by the Corporation. The system will also send the alert to the tenderer at his registered e-mail address about the clarification sought by the Corporation.

(iv) Tenderer will click on clarification icon and will reply to the same and upload the required clarification/documents in support of clarification sought, if any, within the prescribed time. Tenderer cannot ask for any clarification from the corporation.

(v) Once the prescribed time expires, clarification icon from tenderer site shall also disappear automatically.

(vi) After expiry of prescribed time, Corporation shall download the clarification/documents in support of clarification submitted by the bidder.

32. If the tender is made by **Proprietary firm**, it shall be signed by the proprietor with his full name and full name of his firm with its current address.
33. If the application is made by a firm in **Partnership**, it shall be signed by all partners of the firm above their full names and current addresses or by a partner holding the power of attorney for the firm by signing the applications in which case a **certified copy** of the power of attorney shall accompany the application. **A certified copy of the**

**Partnership deed**, current address of the firm and the full names, and current addresses of all the partners of the firm shall also accompany the application.

34. If the application is made by a **limited company or a limited corporation**, it shall be signed by a duly authorized person holding the power of attorney for signing the application in which case a **certified copy of the Power of Attorney** shall accompany the application. Such limited company or corporation will be required to furnish satisfactory evidence of its existence, before the contract is awarded.
35. In the event of any of the documents found fabricated/ tempered/ forged/ altered/manipulated/false during the evaluation of bid at any stage, it will lead to rejection of the bid and forfeiture of EMD of the tenderer. CWC reserve its rights to disqualify the tenderer and to blacklist/ debar for future participation for the next five years.

In the event of any of the documents found fabricated/ tempered/ forged/ altered/manipulated/false in the bid even after the award of the contract, it will lead to termination of the contract, forfeiture of EMD or Performance Security/ Security Deposit whichever is available at the time of termination. CWC reserve its rights to disqualify the tenderer and to blacklist/ debar for future participation for the next five years.

36. 36.1 Notwithstanding anything contained in the clause above, the Tenderer shall execute the Power of Attorney in prescribed format as mentioned in Annexure III and shall conform to the following :-
- 36.2 A company, while executing Power of Attorney must make conformity with the board resolution and the charter documents giving the power to issue the said Power of Attorney including further sub delegation of the same by the said POA holder only.
- 36.3 “Unless notified in writing to the Tendering Authority, the Authority shall recognize only that POA holder for the purposes of tender submission and matters related thereto whose notice and necessary POA document was submitted to the Authority at the time of tender submission”.
- 36.4 While for a partnership firm either all the partners of the partnership firm shall execute and confirm the Power of Attorney if executed or there shall exist a Power of Attorney in favour of the Partners executing the Power of Attorney for the delegation of power on behalf of the Tenderer.
- 36.5 The Power of Attorney being executed by the Tenderer herein shall be executed in favour of only its Partner or Director or Salaried employee. And in case the POA is being executed by the Tenderer in favour of its salaried employee, the said employee should have worked for at least more than one year continuously with the Tenderer and the Tenderer should furnish the following.

- Name
- Designation
- Mobile/Contact no.
- employment letter /agreement issued by the firm

- Identity card with number, issued by the firm
- Information about the wages paid i.e (Salary slips)
- Form-16
- PAN card
- PF Number
- Power of Attorney as per ANNEXURE III

36.6 CWC will not be bound by the Power of Attorney furnished by the Tenderer and acceptance of the same shall be at the sole discretion of the CWC.

36.7 There can validly exist only a single Power of Attorney at any given time. The Power of Attorney executed and accepted by CWC shall stand revoked on issuance of any new Power of Attorney issued within the rules herein, with regard to this particular Project.

36.8 During the subsistence of contract if the Power of Attorney holder is found to be creating mischief or involved in any illegal or unlawful activity, CWC will at its sole discretion reject the Power of Attorney of such person submitted by the Tenderer and the Tenderer would be required to issue a fresh Power of Attorney within the rules herein in favour or authorized person, stated above, within a period of 10 days of being so notified.

37. Should a Tenderer find discrepancies or omissions in the drawings or any of the Tender forms or should he be in doubt as to their meaning, **he should at once notify (within 10 days of start of tender sale) to the authority inviting tenders, who may send a written intimation to all Tenderers.** It should be understood that every endeavour has been made to avoid any error which can materially affect the basis of the tender and the successful Tenderer shall take upon himself and provide for the risk of any error which may subsequently be discovered and shall make no subsequent claim on account thereof.
38. The CWC will not be bound by any power of attorney granted by the Tenderer or by change in the composition of the firm and subsequent to the execution of the contract. It may, however, recognize such power of attorney and changes after obtaining proper **legal advice, the cost of which will be chargeable to the Contractor.**
39. If a Tenderer expires after the submission of his tender or after the acceptance of his tender the CWC shall deem such tender as cancelled. If a partner of a firm expires after the submission of their tender or after the acceptance of their tender, the CWC shall deem such tender as cancelled, unless the firm retains its character. However, in such cases, the amount of earnest money will be refunded to the legal heir on production of successor certificate.
40. **In E-Tendering, Bids in physical form in tender box/by post shall not be accepted.**
41. **Submission of tender and credential documents through E-Tender website [www.cwceprocure.com](http://www.cwceprocure.com) is sole risk & responsibility of the Tenderer. Any claim on this account will not be entertained. Hence, Tenderer should ensure that tender along with all requisite credential papers should be submitted / uploaded on the e-tender website on or before tender submission date and time.**

42. The Tenderer shall have to submit an affidavit as per **ANNEXURE\_IV** along with the tender.
43. The time allowed for carrying out the work will be **3.0 Months** from the date of start as defined in Schedule 'F' or from the first date of handing over the site, whichever is later in accordance with the phasing, if any, indicated in the tender documents.
44. Tender documents consisting of plans, technical specifications, the schedule of quantities of the various classes of work to be done and the set of terms and conditions of the contract to be complied with by the contractor whose tender may be accepted and other necessary documents, can be seen in the office of the **Superintending Engineer/Regional Manager, CWC, RO Bangalore** between 11.00 a.m. to 4.00 p.m. from 25/02/2021 to 11/03/2021 on every working day except on Sundays and Public Holidays.
45. The contractor, whose tender is accepted, will be required to furnish performance guarantee of **5% (five percent)** of the tendered amount within the period **specified in Schedule 'F'**. This guarantee shall be in the form of cash (in case guarantee amount is less than Rs. 10,000/-) or deposit at call receipt of any schedule bank/Banker's cheque of any schedule bank/ demand draft of any scheduled bank (in case guarantee amount is less than Rs.1,00,000/-)/or Govt. Securities or Fixed Deposit Receipts or Guarantee Bonds of any Scheduled Bank or the State Bank of India in favour of **Regional Manager, CWC, RO Bangalore** in accordance with the prescribed form. In case the contractor fails to deposit the said performance guarantee within the period as indicated in Schedule 'F', including the extended period if any, the earnest money deposited by the contractor shall be forfeited automatically without any notice to the contractor.
46. **The contractor should quote the rate online in prescribed proforma available with the tender in Excel format and Digitally sign.** In the event of signing the tender by the Tenderer in an Indian language, the percentage above or below the Estimated Cost and tendered amount in case of percentage rate tenders and total amount in case of item rate tender should also be written in the same language. In the case of illiterate contractors, the rates or the amounts tendered to be attested by a witness.
47. The Tenderer, apart from being a contractor of appropriate class must associate himself with agencies of the appropriate class which are eligible to tender, for (i) Electrical (ii) Sanitary and Water Supply Installation and (iii) Horticulture.
48. The contractor shall not be permitted to tender for works in the Central Warehousing Corporation in which his near relative is posted as Accounts Officer or as any officer in any capacity between the grade of Chief Engineer and Assistant Engineer (both inclusive). He shall also intimate the names of persons who are working with him in any capacity or are subsequently employed by him and who are near relatives to any officer in the Central Warehousing Corporation or in the Ministry of Consumer Affairs, Food & Public Distribution, Govt. of India, New Delhi. The Corporation reserves the right to debar the TENDERER from participating in future bidding processes of the CORPORATION for a minimum period of five years, which may be further extended at the discretion of the CORPORATION for any breach of this condition.

49. No Engineer employed in Engineering or Administrative duties in Engineering Division of the Corporation is allowed to work as a contractor and also an employee of contractor for a period of **two years** after his retirement from Corporation service, without the previous permission of the Central Warehousing Corporation in writing. This contract is liable to be cancelled if either the contractor or any of his employees is found at any time to be such a person who had not obtained the permission of the Central Warehousing Corporation as aforesaid before submission of the tender or engagement in the contractor's service.

50. **Conditions of Contract and Specifications:**

50.1 Works will be carried out according to the Conditions of Contract, CPWD Specifications with upto date correction slips along with special conditions of contract, technical specifications and approved drawings of CWC issued with this tender document. For roads and pavements, MORTH Specifications shall be followed. If, however, any particular item or issue is not covered by these specifications and special specifications, then the work shall be carried out in accordance to relevant BIS (IS) Codes and Code of practice.

50.2 The following publication can be obtained from Secretary, Indian Road Congress, Jam Nagar House, New Delhi, book shops:

- I) MORTH Standard Specification (latest revised edition) for Road and bridge work; along with up to date correction slips for roads and pavements.

50.3 CPWD Specifications & DSR with up to date correction slips can be obtained from CPWD office, Nirman Bhawan, New Delhi.

50.4 The bid document shall be taken as complimentary and mutually explanatory of one another but in case of ambiguity or discrepancy, shall take precedence as per Conditions Of Contract.

51 The contractor shall submit list of works which are in hand (Progress) in the following form:

Name of Work	Name and Particulars of Divisions of Department/ Organisation where work is being executed	Amount of work	Position of work in Progress	Remarks
1	2	3	4	5

52. The special conditions of contract shall be read in conjunction with General Conditions of Contract. Where the provisions of special conditions of contract are at variance with above mentioned documents, the special conditions of contract shall prevail.

53. It is brought to the notice of tenderers that their tender will not be considered if they fail to fulfil the minimum eligibility as indicated in Annexure-A.

54. **The Price Variation Clauses namely- Clause 10 C, Clause 10CA & Clause 10CC, for Mobilisation Advance Clause 10B(ii), plant machinery and shuttering material advance**

**Clause 10B (iii) and for Interest & Recovery Clause 10B(iv) & (v) of Conditions of Contract are not applicable in this contract work. The Price quoted by the tenderer and accepted by CWC shall remain firm during the currency of contract including the extended period if any. No claim whatsoever shall lie against the Corporation on account any variation/ Escalation etc. in the rates.**

- 55. The Clause 2A for 'Incentive for Early Completion' is not applicable in this contract work.**
- 56. The validity of the tender will be ninety (90) days from the date of opening of Technical Bid.**
- 57. Tender form should be purchased by the bidder who is participating in the tender i.e. Tender form should be in the name of bidder. Otherwise, tender offer will be summarily rejected.**

Superintending Engineer

For and on behalf of  
Central Warehousing Corporation



**SECTION – II**  
**(MINIMUM CRITERIA FOR ELIGIBILITY OF THE TENDERERS)**

**Name of Work:** Major repairs and strengthening to Gable walls of Godown No. 2A to avoid differential settlement and remedial measures including Piling at CW Gadag-II,( Karnataka)

**MINIMUM CRITERIA FOR ELIGIBILITY OF THE TENDERERS**

- 1) **EMD, Cost of Tender & Tender Processing Fees:** The EMD to be paid in favour of **Central Warehousing Corporation, New Delhi only through e-payment gateway of e-procurement** and receipt of the same should be scanned and uploaded on the e-tendering website [www.cwceprocure.com](http://www.cwceprocure.com) along with e-tender documents.  
Cost of tender to be paid **only through e-payment gateway of e-procurement system.**  
**Proof to be submitted/uploaded with the tender.**  
Tender processing fee (Non- refundable) would be paid mandatorily to M/s ITI Ltd. through e-payment through the portal [www.cwceprocure.com](http://www.cwceprocure.com).
- 2) **EXPERIENCE CERTIFICATE:** Tenderer should have completed successfully at least one similar nature of work " i.eAny Civil Works including cement concrete works, RCC Works, Piling works OR Masonry works or Finishing works OR road works OR Construction of Godowns or Industrial sheds or Building Works along with associated works of drain, road , circulating area)" of value not less than Rs. **12.56 Lakhs**(Rupees Twelve Lakh Fifty Six Thousand)(35% of the advertised Estimated Cost) during the last **four** financial years (i.e. 2016-17, 2017-18, 2018-19 & 2019-20) and current Fy. Year 2020-21 up to the date of tender submission. Certificate should include the name of work, agreement number, date of start, actual date of completion & gross amount of work done up to the completion.  
**NOTE:** It should be noted that credentials for the works executed for Private Organisations shall not be considered.
- 3) **TURNOVER:** The sum total (arithmetic sum) of tenderer's turnover/ revenue (income) from operations for the last three financial years (i.e2017-18, 2018-19& 2019-20) should be of value not less than Rs. **32.29 Lakhs (Rupees Thirty Two Lakh Twenty Nine thousand) ;(90% of advertised Estimated Cost).**  
The information shall be supported by CA certificate & audited Balance Sheets and of Profit & Loss Statements of specified last three financial years. In case Balance Sheet and Statement of Profit & Loss for the immediate preceding financial year have not been prepared/audited, the account for one more preceding financial year can be submitted.
- 4) **AFFIDAVIT (ANNEXURE-IV)** duly filled up and signed on stamp paper.  
**NOTE:** i) Tenderer not fulfilling the above requirements or submission of clarification documents with respect to mandatory document, shall be **summarily rejected.**  
II) In case the tenderer does not submit **turnover** for any of the specified financial year(s), then the turnover for that year shall be taken as "NIL" for the purpose of evaluation of tenderer.  
III) For judging the technical eligibility only those works which had been executed for the Govt. or Semi-Governmental Organisation, State Govt., PSU & their subsidiary shall be considered and the tenderer will submit the certificate to this effect from the officer concerned duly signed under the official seal. **It should be noted that credentials for the works executed for Private Organizations shall not be considered.**  
IV) The work experience certificate of works executed on back to back basis/ sub-letted works shall not be considered.

**SUPERINTENDING ENGINEER**

**SECTION – III**  
**(SPECIAL CONDITIONS OF CONTRACT)**

## SPECIAL CONDITIONS OF CONTRACT

**The scope of work includes: Construction of central warehousing Corporation Godown as per Technical Specifications and Special, General & Technical Conditions of Contract.**

Key Component of Scope are:

- a. ) Demolishing of failed wall panels,
- b. ) Demolishing existing Lintels and tie beams in end panels.
- c. ) Demolishing damaged drains and plinth protections
- d. ) Demolishing Existing flooring as well as WBM in godowns and verandah and disposing the backfilled B.C soil inside the flooring areas.
- e. ) Demolishing wall foundations of verandah.
- f. ) Boring Pile foundation for new columns.
- g. ) Constructing new RCC Columns and connecting the same with old columns by anchoring at 3 levels.
- h. ) Connecting new columns with each other and plinth, lintel and tie level.
- i. ) Rebuilding demolished foundations of verandah (upto the new columns) as per the drawings and specifications of CWC.
- j. ) Filling complete Verandah floor area with fine sand and godown flooring area with good earth and consolidating the same.
- k. ) Providing and laying WBM in Gr.I&II with screening material as base course for flooring.
- l. ) Reconstruction of damaged failed wall panels with CC block masonry and constructing new gable wall with CC Block masonry in new columns.
- m. ) Providing Plinth band and anchoring the same by drilling holes in adjacent columns.
- n. ) Providing lintel band and anchoring the same by drilling holes in adjacent columns.
- o. ) Providing tie band and anchoring the same by drilling holes in adjacent columns.
- p. ) Laying of Cement concrete flooring in godowns and verandahs with floor hardners and cutting grooves.
- q. ) Making cement concrete apron of CC 1:1.5:3 in place of plinth protection at gable wall side of godown 2A.
- r. ) Reconstructing demolished/damaged drains and plinth protections in other godowns.
- s. ) Carrying out other miscellaneous repair works in doors of all godowns.

1.0 **GENERAL**

- 1.1 The contractor will engage the experienced **Technical representatives** of concerned discipline on the project, who should have the full knowledge of work and are capable of getting executed the work and removing defects as pointed out by the Engineer-in-charge. The deployment of the technical representatives and recovery, in case the contractor fails to do so, shall be in accordance with the **Schedule-F**.
- 1.2 The contractor shall procure all construction materials well in advance so that there is sufficient time for testing of the materials and clearance of the same before incorporation in the works. In case untested material is used by the contractor and later on the same is found not meeting to specification requirement, then, the executed work with said material shall be dismantled and re-executed at the cost of contractor.
- 1.3 Wherever there is a reference to I.S. Code/Specifications or any other code, it shall refer to latest code with correction slips as in vogue on the date of tendering.
- 1.4 The contractor shall make his programme of work in consultation with the Engineer-in-Charge keeping in view the availability of materials and unavoidable hindrance. No claim whatsoever will be entertained due to delay on this account.
- 1.5 Before commencement of work, the contractor shall take levels and record them in prescribed Level book. The levels taken shall be got verified from Engineer-in-Charge or his representative.
- 1.6 The work shall be carried out in a manner complying in all respects with the requirements of prevalent byelaws of the local Municipality/Municipal Corporation.
- 1.7 The rates quoted by the Tenderers/contractors shall be inclusive of GST or all applicable taxes, Building and other Construction Workers Welfare Cess, levies, duties on materials or services and on complete works in respect of this contract shall be payable by the contractor and Central Warehousing Corporation will not entertain any claim whatsoever in this respect. This should be included in the rates quoted by the contractor.
- 1.7.1 However, contractor is required to submit tax invoice as per rules under GST law.
- 1.7.2 CWC shall deduct GST at source at applicable rates in case transactions under this contract are liable to GST deduction at source.
- 1.7.3 Under GST regime, the contractor is required to correctly and timely disclose the details of output supply to GST as per GST rules in his GST return. Non-compliance would result in mis-matching of claims and denial of input tax credit to CWC. Notwithstanding, anything contained in the agreement/contract in case of such default by the contractor, the amount of input tax credit denied in GST alongwith interest and penalty shall be recovered from the contractor.
- 1.7.4 Unless expressly stated, otherwise, where any identifiable cost saving are realized during the currency of contract by virtue of deduction:
- (i) In rate of tax on supply of goods and services.
  - (ii) Any benefit of input tax credit accrued to the contractor, contractor shall be passed on such benefit to CWC by way of commensurate reduction in prices.

## 2.0 **PERIOD OF COMPLETION**

The work is required to be completed within time schedule from the date of issue of acceptance letter as given below: -

Total period of completion: **3 Months (in figures) ThreeMonths (in words)from the 15<sup>th</sup> day after issue of Letter of Acceptance (LOA).**

2.1 The contractor shall stick to the final completion date and will be liable to action for any delay due to contractor as per Conditions of Contract for stage as well as overall completion of the work.

2.2 In case of termination of contract, available EMD, PG & Security Deposit with the department against the said contract will be forfeited.

## 3.0 **Delay or Deferments**

3.1 Where the Contractor has to work along with other agencies in and around the area allotted for his works, he shall execute all his works in complete **coordination and cooperation** with all such agencies so that at no time either his work or the works of other agencies is stopped or delayed. In case of any dispute in this regard the decision of CWC or their representative will be final and binding on the Contractor. No claim for idle labour, plant and machinery under any circumstances will be entertained by the CWC.

3.2 During the execution of this work, the Warehouse will be operational. Contractor has to execute all works in complete coordination and cooperation with all activities confined to the area within the scope of this work, so as not to affect the operation of Warehouse under any circumstances. In case of any dispute in this regard, the decision of CWC or their representative will be final and binding on the contractor. Contractor shall also note the work shall progress as per the phased development, if any.

## 4.0 **Measurements for Works/Record Measurements**

4.1 The contractor shall ensure that measurements for all work which may be partially or wholly hidden in the course of construction are duly recorded in the Measurement book before that portion of work becomes inaccessible for measurement.

4.2 For works running/on account payments can be made on the basis of detailed measurements recorded in the measurement books for the actual work executed. The bills will be submitted by the contractor as per Bill Proforma enclosed, and the date of submission of the bills will be considered as the date of acceptance of bill/ signing of bill which is to be recommended & forwarded by the Engineer-in-Charge concerned for arranging payment.

## 5.0 **Payment to be made by CWC**

5.1 **The clauses 10 B (ii),(iii),(iv),(v),10C, 10 CA, 10CC and 2A under Clauses of Contract have been deleted and no claim by the contractor in this regard will be entertained.**

5.2 The contractor will submit running account bills of value not less than **5% value of the contract amount** towards the work done (excluding secured advance, if any).

5.3 For payment of Running Account Bills, the mandatory documents, like copy of paid challans of PF/ ESI, Royalty (if applicable), paid bills of water & electricity, copy of **Workmen Compensation Policy**, copy of labour license, Theoretical Consumption Statement of Cement, Steel & Bitumen, Invoice of cement, steel & bitumen, test reports, Proof of deployment of Site Engineer etc, shall be required at the time of 1st RA bill & final bill. For intermediate RA bills, above documents if not available due to reasons stated by contractor with undertaking to comply, may be relaxed by Engineer-in-charge. However, contractor must comply the statutory and other provisions. Contractor shall indemnify the CWC against all losses / damages due to non-compliance of above provisions at intermediate stage of any.

5.4 Income tax as well as works contract tax or any other tax/ levy as applicable by the Central / State Govt. shall be recovered on the gross amount of each bill.

#### **6.0 Procurement, Storage, and Payment of Cement, Steel and bitumen, etc,**

6.1 The contractor shall procure Portland Pozzolana Cement (PPC) as per IS-1489 Part-I in all the works except Cement Concrete pavement works wherein Ordinary Portland Cement (OPC) of grade 43 (as per IS:269:2015) and /or 53 grade (as per IS: 269:2015) shall be used. The PPC & OPC cement to be used shall be of approved make as specified in the list of Approved Makes (enclosed with Technical Specifications).

6.2 The contractor shall procure steel reinforcement bars conforming to IS 1786:2008 pertaining Fe415D or Fe500D, structural steel conforming to IS-808 and bitumen should conform to I.S. code 702 and 703 as per the item/drawing from manufacturer's of approved make as specified in the list of Approved Makes (enclosed with Technical Specifications).

The storage of cement should be done by contractor as per IS-4082-1996 (recommendation on stacking and storage of construction materials at site). Sheds having capacity as decided by Engineer-in-Charge to store the cement shall be provided by contractor for which no extra payment shall be made. All such sheds/store, after completion of work shall be removed by contractor at his own cost and site shall be cleared.

6.3 The cement & steel reinforcement shall be brought at site in bulk supply of approximately 50 tonnes & 10 tonnes respectively or more or as decided by the Engineer- in-charge. Each bag of cement must weigh 50 kg, subject to variation as per BIS code, bearing manufacturer's name & ISI marking.

6.4 The contractor shall be responsible for the watch & ward, safety of the Cement store/shed, Bitumen & Steel. The contractor shall facilitate the inspection of the same by the Engineer-in-charge at any time. The material supplied by the contractor should be in countable position and properly stacked.

6.5 The steel reinforcement shall be stored by the contractor at site of work in such a way as to prevent distortion & corrosion and nothing extra shall be paid on this account. Bars of different sizes and lengths shall be stored separately to facilitate easy counting and checking.

- 6.6 For checking nominal mass, tensile strength, bend test, re-bend test etc. specimen of sufficient length shall be cut from each size of the bar at random at frequency not less than that specified below:

Size of bar	For consignment below 100 tonnes.	For consignment over 100 tonnes
Under 10 mm dia.	One sample for each 25 tonnes or part thereof.	One sample for each 40 tonnes or part thereof.
10 mm to 16 mm dia.	One sample for each 35 tonnes or part thereof.	One sample for each 45 tonnes or part thereof.
Over 16mm dia.	One sample for each 45 tonnes or part thereof.	One sample for each 50 tonnes or part thereof.

- 6.7 Proper daily record of cement, steel, paint and bitumen consumption shall be maintained at site by the Contractor. The register shall be duly signed by the Contractor/ authorised representative of contractor and the same will be checked by the site engineer/ Engineer in charge from time to time. In case concrete is being obtained from RMC plant, then, the record of cement of the same shall be kept based on the computerized receipt of mix proportion of each lot. The actual issue and consumption of cement & steel on work shall be regulated and proper accounts maintained as provided in clause 10 of the contract. The theoretical consumption of cement shall be worked out as per procedure prescribed in clause 42 of the contract and shall be governed by conditions laid therein.
- 6.8 **Return of Empty Cement Bags:-**Cement issued to the contractor or procured by the contractor will be in gunny bags/paper bags/polythene bags. The empty gunny bags / polythene bags shall be the property of the contractor.
- 6.9 Payment for steel reinforcement shall be made on the basis of standard weight of the bars used as per approved drawings. in case weight of bars is more than or less than the standard weight but within the tolerance limit as specified in BIS, the payment will be restricted to lesser weight in case of steel having less weight than the specified and standard weight, in case steel having more weight than specified.
- 6.10 Cement, Steel & Bitumen brought to site and remaining unused after completion of work shall not be removed from site without written permission of the Engineer-in-charge.
- 6.11 No claim whatsoever shall be entertained by CWC on account of delay in non-availability of these materials in the market.
- 6.12 Clodding of cement and rusting of steel should be avoided to the maximum extent possible. For such clodding of cement and/or rusting of steel which may render the same unusable, the contractor shall be responsible to make good such quantities the loss at his own cost.
- 7.0 **R.C.C. & Plain Cement Concrete work:**
- 7.1 Hard stone aggregate of different sizes shall be crushed or broken from hard stone conforming to CPWD Specifications for work subject to para below. Where CPWD



Specifications for R.C.C. or any item or work are silent, the provisions of the Latest Code of Bureau of Indian Standard for plain and reinforced cement concrete for general building construction I.S. 456--2000. or the concerned I.S. specifications or code of practice shall apply.

7.2 When an R.C.C. slab or a flat slab is projected beyond the wall/beam line, the payment for such projected part of the R.C.C. work shall be made under the corresponding item of R.C.C. slab/flat slab. The payment for the centering and shuttering of the projected portion shall also be made under the item of centering & shuttering for the slab/ flat slab. Nothing shall be paid for the edge shuttering of the slab/flat slab project or otherwise. All exposed edges shall be finished as per specifications without extra payment.

#### 8.0 **Testing of Materials**

8.1 Contractor will be required to establish a field laboratory for new works. The setting of field laboratory for the new works of value more than Rs.2 crore is a mandatory requirement. Contractor shall be responsible for setting up laboratory facilities, equipment's and arranging technical manpower at his cost, as directed by the Engineer-in-charge for conducting site/field test. All the equipment's shall be BIS approved makes and will be got checked/ calibrated regularly. All equipment's of the laboratory shall be kept in good working conditions. If contractor fails to provide field laboratory for new works within one month of commencement of work, shall attract a penalty of Rs. 25,000 per month recoverable from the running bills. In all routine tests, which can be normally done in the field laboratory/in situ, testing charges will be borne by the contractor. In case contractor fails to conduct field laboratory test for new works than all required tests shall be carried out in the reputed/approved outside laboratory. So far as conducting required test for upgradation/ repairing works, same would be carried out in the reputed/approved outside laboratory. The Payment of testing charges of such tests will be borne by the contractor in both the cases.

8.2 The contractor has to produce a Manufacture Test Certificate (MTC) from manufacturer to the Site Engineer for the cement, steel, bitumen etc, for every consignment procured, failing which no consignment of cement, steel and bitumen etc will be accepted by the Site Engineer.

8.3 The testing and acceptance of criteria for cement and steel and any other materials supplied by the contractor should be as per BIS codes/Technical Specification or as decided by the Engineer-in-charge as per the stipulated testing frequency given in enclosed list or CPWD Specifications.

8.4 Sample of material for testing will be supplied free of cost by the contractor, including its transportation to the approved test houses/laboratory, as directed by the Engineer-In-charge or inspecting officials.

8.5 For outside testing, test of materials and stipulated samples shall be carried out by one of the following laboratories/ tests houses (1) IIT (2) NIT (3) National Test Houses (4) National Council of Cement & Building Material (5) Govt. Engg. College/National Accreditation Board Approved Lab (NABL), as per decision of the Project Incharge/ Site Engineer. The testing charges shall be borne by the contractor.

- 8.6 All Routine tests on various materials shall be carried out as per the List of Mandatory Tests (enclosed) at the cost of the contractor. Wherever if same is not specified then it will be carried out as per decision of Site Engineer which will be final and binding.
- 8.7 In addition to the tests required under above clauses thereof, the engineer or his representative may order tests to be carried out by an independent person appointed by him at such place or in such laboratory as he may determine in accordance with the appropriate clauses of relevant standard specifications and the cost of such tests shall be borne by the contractor.
- 8.8 Testing record shall be maintained as per standard Testing Performa enclosed in tender document for proper testing and their record by the contractor.
- 8.9 In case, test results indicate that the cement, steel & bitumen arranged by the contractor does not conform to the relevant BIS codes, the same shall stand rejected and shall be removed from the site by the contractor at his own cost within a week's time of written order from the Engineer-in-charge to do so.
- 9.0 Plant & Machinery Required for the Works**
- 9.1 It will be the responsibility of the Contractor to arrange all plant & machinery, trucks, vibratory, Road roller, etc, required by him for execution of works.
- 9.2 The contractor will also arrange for getting permission (for their use) if required from local or other concerned authorities for use as well as for their transportation to site.
- 9.3 All expenditure incurred in this connection will be borne by the Contractor.
- 10.0 Arrangement of Water for execution of works**
- 10.1 The contractor will have to make his own arrangements for obtaining water to be used for execution of the works or CWC may supply water if available, for execution of work as per provision of Clause 31 or 31 (A), respectively of Conditions of Contract. However, CWC may allow labourers to use the drinking water facility of the Warehouse, if necessary.
- 10.2 CWC may permit to contractor to install borewell at site at his own cost for execution of work. In this case contractor will ensure compliance of statutory requirements of the regulatory authority. After completion of the work, he shall restore the ground to its original condition after the borewell/s is/ are dismantled as per Clause 32 of Conditions of Contract.
- 11.0 Arrangements for Electric connection, Lighting & other purpose**
- 11.1 If for reasons of urgency, the work has to be executed at night, contractor shall make his own arrangement for illuminating the site. Nothing extra will be paid for doing works at night.

- 11.2 Contractor will have to make his own arrangements for arranging electricity if the same is required for illumination purposes or for running of any plant or machinery and nothing extra will be paid for the same.
- 11.3 CWC may allow electric power, if available, on actual electric energy consumption by putting separate electric energy meter with due permission of Site Engineer.
- 12.0 **Maintenance after Completion**
- 12.1 All works executed under this agreement shall be maintained by the contractor at his own cost for a period of **12 (twelve) months** from the actual date of completion or during defect liability period as per Clause 17 of General Conditions of Contract.
- 13.0 **Miscellaneous**
- 13.1 Customary standards/local traditions will not be the criteria for the standards. All works shall be up to the CPWD standards and as ordered by Engineer in-charge and where any doubt may exist the specifications as given in the CPWD Specifications Vol.-I & II should be followed. Should there be any difference in the particular specifications for individual items of work and the description of the item as given in the schedule of quantities the latter shall prevail. In case of items not covered by the general specifications referred to above or particular specifications attached reference shall be made to the appropriate B.I.S. code and the decision of the Engineer-in-Charge shall be final and binding on the contractor.
- 13.2 CWC may provide space for setting up construction plants, T & P, site office, laboratory, storage of material, labour, etc, free of cost if the surplus land is available with prior permission from the Engineer In-charge during the construction period of the project.
- 13.3 No areas outside work site/ depot will be made available to the contractor for storage of construction materials and construction of site office etc, and if required, contractor will make his own arrangement for the same by personal negotiation with the owners at his own cost.
- 13.4 The rates for different items of work shall be for all heights and depths, except where otherwise specified.
- 13.5 The contractor shall quote his rate taking into account the restrictions, if any, on entry/exist of vehicles and labour to/from the site of work as laid down by Central Warehousing Corporation and other Govt. authorities. If any entry fee/other charges are levied by any authority on entry of the vehicle/material/labour same shall be paid by the contractor. No claim or compensation on this account shall be entertained from the contractor.
- 13.6 The contractor must take all precautions to avoid accidents by exhibiting day and night necessary caution boards, speed limit boards, red flags and red lights and providing barriers. He shall be responsible for all damage and accidents caused due to negligence on his part. No hindrance shall be caused to traffic during execution of work.

- 13.7 Any damage done by the contractor or his work-men to any existing work during the course of execution of the work, tendered for, shall be made good by him at his own cost.
- 13.8 The contractor shall maintain in good condition all work executed till the completion of entire work allotted to the contractor.
- 13.9 The contractor shall clean the site thoroughly of all rubbish etc. left out of his materials on completion of the work and roughly dress the site around the building line to the satisfaction of the Engineer-in-Charge.
- 14.0 **Handling of Materials**
- 14.1 No lead is payable on water for works done under any section of DSR or for the work done under any Non Scheduled Item (NSI) Rate.
- 14.2 If food grains/ goods stored in the Warehouse are lost, stolen or damaged during execution of construction work by the contractor or his labourers, the cost of the same @ twice of the prevailing market rate will be recovered from the Contractor's dues and Contractor will have no claim whatsoever on this account.
- 14.3 During execution of work, if CWC materials (i.e., cables and pipelines, drains etc, are damaged then same will be set right by contractor at his cost within a reasonable time as decided by the Engineer-in-charge. In case contractor fails to rectify the damages caused during construction/ under their custody, the cost of the damaged material shall be recovered from the contractor @twice of prevailing market from the contractor dues/ bills and contractor will not have any claim whatsoever on this account.
- 14.4 The contractor shall consult the Engineer-in-Charge in writing regarding collection and stacking of materials required for the work. He should not stack materials at any places other than those approved by the Engineer-in-Charge. No excavated earth or building material shall be stacked on area where other buildings roads, services or compound wall are to be constructed.
- 15.0 **Adherence to labour law and regulations**  
The Contractors, who are working in the establishments through Contract Labour and/or employing labour themselves directly should get themselves registered with the Assistant Labour Commissioner concerned as required under Contract Labour (Regulation and Abolition) Act 1971 and obtain a license from the Assistant Labour Commissioner concerned and produce the same to Engineer-in-charge, in compliance to above and the Conditions of Contract. However, a copy of application for obtaining labour license may be submitted to Engineer-in-charge within the period as specified in Schedule 'F'.
- 16.0 **Employment of labour from scarcity area**  
If the Government declares a state of scarcity of famine to exist in any village situated within 15 kms of the work, piece worker/contractor shall employ upon such parts of the works as unskilled labour any person found suitable and certified to him by the Engineer-in-charge or by any person to whom the Engineer-in-charge may have delegated in writing, to be in need to relief and shall be bound to pay to such person wages not below the minimum which

Government may have fixed in this behalf. Any dispute which may arise in connection with the implementation of this clause shall be decided by the CWC whose decision shall be final and binding on the piece worker/ contractor.

#### 17.0 **Provision of altered/additional items**

If the altered/additional work required to be executed as per CWC's requirements, for which there are no established rates in Schedule of Rates, the same shall be payable as per provisions stated hereunder: -

- a) As far as possible the rates for such items shall be derived from agreed schedule of rates on pro-rata basis.
- b) If direct working out is not possible, the contractor shall be paid on the basis as under: -
  - (i) Material, labour either or both: Reasonable cost of materials plus reasonable cost of labour inclusive of tools, plants and machinery and plus 15% of so derived cost, to cover contractor profit, supervision, overheads, establishments, etc.
  - (ii) Engineer-in-Charge's decision regarding reasonable labour cost and reasonable material consumption/and cost shall be final and binding on contractor.
- c) The rates can also be derived based on the Last Approved Rate (LAR) of similar items of same area or nearby area.

#### 18.0 **Completion Drawings**

18.1 Completion drawings of all the completed works for showing the layout of the area with dimensions, slopes and details of building, reinforcements used, pavement, drain, cable trenches, machine foundations, etc, shall be prepared by the contractor at his own cost.

18.2 Contractor will supply **three copies** of completion drawings along with soft copy in CD / Pen-drive with the final bill. In case contractor does not submit the completion drawing within **30 days** of completion of the work or alongwith submission of final bill (whichever is later), he shall be liable to pay a sum **as prescribed in Schedule F** and in this respect the decision of the Engineer-in-charge shall be final and binding on the contractor.

#### 19.0 **Storage of inflammable articles**

No inflammable materials, such as petroleum, oil, etc, within the meaning of the Indian Petroleum Act and Indian Explosives Act shall be stored at site or adjacent land until the approval of the CWC and necessary license under the Act has been obtained by the contractor. All due precautions as required under the Acts shall be taken by the contractor.

#### 20.0 **Night Work**

If the CWC is however satisfied that the work is not likely to be completed in time except by resorting to night work, by special order, the contractor would be required to carry out the work even at night, without conferring any right on the contractor for claiming for extra payment for introducing night working. The decision of the Site Engineer in this regard will be final and binding on the contractor.

**21.0 Notice to Public Bodies: -**

The contractor shall give to the Municipality, Police and other authorities, all notices that may be required by the law and obtain all requisite licenses for temporary obstructions, enclosures and pay all fees, taxes and charges, which may be leviable on account of his own operations in executing the contract. He should make good any damage to adjoining premises whether public or private and provide and maintain any light, etc, required at night and no extra payment will be made on this account.

**22.0 Plea of custom: -**

The plea of 'Custom' prevailing will not on any account be permitted as an excuse for infringement of any of the conditions of contract or specifications.

**23.0 Care of Staff: -**

No guarantee will be provided by CWC for accommodation of the contractor or any of his staff employed on the work. The contractor may be allowed to erect labour camps for housing the labour at or near the site of work on available CWC's land. The contractor shall at his own cost make all necessary and adequate arrangements for importation, feeding and preservation of the hygiene of his staff. The contractor shall permit inspection at all times of all sanitary arrangements made by him by the Engineer-in-Charge or his assistant or any official of the CWC. If the contractor fails to make adequate medical and sanitary arrangements, these will be provided by the CWC and the cost thereof will be recovered from the contractor.

**24.0 First aid: -**

The contractor shall maintain in a readily accessible place first aid appliance including an adequate supply of sterilized dressing and sterilized cotton wool. The appliances shall be placed under the charge of responsible person who shall be readily available during working hours.

**25.0 Trespass: -**

The contractor shall at all times be responsible for any damages or trespass committed by his agents and workmen in carrying out the work, unless such trespass is authorized by the Engineer at site.

**26.0 Damage from Accidents or floods or Tides: -**

26.1 The contractor shall take all precautions against damages from accidents, floods or tides. No compensation will be allowed to the contractor for his tools, plants, materials, machines and other equipment lost or damaged by any cause whatsoever. The contractor shall be liable to make good the damages to any structure or part of structure, plant or material of every description belonging to the CWC administration, lost or damaged by any cause during the course of contractor's work.

26.2 The CWC will not be liable to pay to the contractor any charges for rectification or repairs to any damages, which may have occurred from any cause whatsoever, to any part of the new structures during construction. No claims in this regard will be arbitrable.

26.3 The contractor shall bail out rain water collected during execution of work from the excavated trenches at his own cost. Nothing extra shall be payable on this account.

**27.0 Use of CWC Materials secured with Government Assistance: -**

27.1 Where any raw materials for the execution of the contract are procured with the assistance of Govt. either by issue from Government, stocks or purchases under arrangements made or permit(s) or licence (s) issued by the Government, the contractor shall hold the materials as trustee for the Government and use such materials economically and solely for the purpose of contract against which they are issued and not dispose them off without permission of the Government and return if required by the Government all surplus or unserviceable materials that may be left by him after completion of the contract or at its termination for any reason whatsoever on his being paid such price as Government may fix with the due regard to the condition of the materials. The freight charges for the return of the material according to the direction of the purchaser shall be borne by the contractor, in the event of contract being cancelled for any default on his part, the decision of Government shall be final and conclusive.

**28.0 Insurance for Works persons and property**

**28.1 Insurance for Works**

The contractor at the scheduled date of start of work without limiting his obligations and responsibilities, shall insure the works at his own cost and keep them insured until the virtual completion of the contract against all acts of God including Fire, Theft, riots, War, Floods, etc, with a Insurance Agency approved by Insurance Regulatory and Development Authority (IRDA) in the joint names of the employer and Contractor (the name of the former being placed first in the policy) for the minimum thirty percent amount of the originally awarded contract value irrespective of revised / modified contract value later on. Such policy shall cover the property of the CWC and fees for assessing the claim and in connection with his services generally therein and shall not cover any property of the Contractor or of any sub contractor.

The Contractor shall deposit the policy and receipt for the premiums with the CWC within 30 days from the date of signing the contract or commencement of execution of work, whichever is earlier, or unless otherwise instructed by the CWC. In default of the Contractor insuring as provided above, the CWC on his behalf may so insure and may deduct the premiums paid from any moneys due or which may become due to the Contractor. The Contractor shall, as soon as any claim under the policy is settled or the works reinstated by the Insurance Office should elect to do so, proceed with all due diligence with the completion of the works in the same manner as though the misfortune/accident had not occurred and in all respects under the same conditions of contract. The Contractor in case of rebuilding or reinstatement after accident shall be entitled to such extension of time for completion as the CWC deems fit.

**28.2 Insurance in respect of damages to persons and property**

- i) The Contractor shall be responsible for all injury to persons, animals or things and for all structural and decorative damage to property which may arise from the operation or neglect

of himself or of any approved sub contractor's or Employees, whether such injuries or damage arise from carelessness, accident or any other cause whatsoever in any way connected with carrying out of this contract. The clause shall be held to include any damage to buildings, whether immediately adjacent or otherwise and damage to road, streets footpaths, bridges and works forming the subject of this contract by frost or other inclemency of the weather. The Contractor shall indemnify the CWC and hold him harmless in respect of all and any expenses arising from any such injury or damage to persons or property as aforesaid and in respect of any claims made in respect of injury or damage under any Acts of government or otherwise and also in respect of any award of compensation of damage consequent upon such claims.

- ii) The Contractor shall reinstate all damages of every sort so as to deliver up the whole of the contract works complete and perfect in every respect and so as to make good or otherwise satisfy all claims for damage to the property of third parties.
- iii) The Contractor shall indemnify the CWC against all claims which may be made against the CWC by the member of the public or other third party in respect of works in consequence thereof and shall at his own expense arrange to effect and maintain, until the virtual completion of the contract, **an Insurance Policy with Insurance Agency approved by IRDA in the joint names of the CWC and Contractor against such risks and deposit such policy or policies with the CWC from time to time during the currency of this contract.** The contractor shall similarly indemnify the CWC against all claims which may be made upon the CWC whether under the Workman's Compensation Act or any other statute in force during the currency of this contract or at common law in respect of any employee of the Contractor or any sub-contractor and shall at his own expense effect and maintain with an approved office a policy of insurance in the joint names of the CWC and the Contractor against such risks and deposit such policy or policies with the CWC from time to time during the currency of the Contract. The Contractor shall be responsible for anything which may be excluded from the Insurance policies above referred to and also for all other damage to any property arising out of an incidental to the negligent or defective carrying out of this contract. He shall also indemnify the CWC in respect of any costs, charges or expenses arising out of any claim re-proceedings and also in respect of any award of or compensation of damages arising there from.
- iv) The Employer shall be at liberty and is empowered to deduct the amount of any damage, compensation costs, charges and expenses arising or accruing from or in respect of any such claim or damage of any sum or sums due to or become due to the Contractor including the Security Deposit.
- v) If the Contractor fails to comply with the terms of these conditions, the Employer may insure the works and may deduct the amount of the premiums paid from any moneys that may be or become payable to the Contractor or may at the option, do not release running payment to the Contractor until the Contractor shall have complied with the terms of this condition.

**29.0 ANY OTHER INSURANCE REQUIRED UNDER LAW OR REGULATIONS OR BY CWC.**

Contractor shall also carry and maintain any other insurance which he may be required under law or regulation from time to time. He shall also carry and maintain any other insurance which may be required by CWC.



**30.0 SITE OFFICE**

Contractor shall have to provide temporary site office with requisite furniture & appliances and godown for storing/stacking construction materials at their own cost for which no extra payment will be made.

**31.0 PF COMPLIANCE**

It will be responsibility of the contractor to obtain separate code/identification No. for contractor's deposit of PF dues, if applicable with concerned authority directly. Copy of PF Registration / code no. along with copy of PF paid Challans shall be submitted along with Running Account or Final Bill.

**32.0 Recoveries/Withhold**

32.1 In case of any technical deficiencies, lapses on account of non-compliance of PF/ESI, Insurance (WC Policies), labour license, or any other reasons not covered in any clause of tender documents etc., are noticed by the Engineer-in-charge/CWC Vigilance Deptt./ CTE Organization, then a sum as recommended or decided by Project In-charge/ Site Engineer may be withheld, till rectification/remedy/compliance of the deficiencies.

32.2 Recoveries, if any, on account of uncovered period of insurance (WC Policies), defective work, losses to CWC or any other liability not fulfilled by contractor etc., shall be effected from the contractor's bill/any other due (s) amount (i.e. Final Bill, Security Deposit & Performance Bank Guarantee, etc.).

**33.0 Material obtained from the dismantlement:**

The contractors, in the course of their own work, should understand that all materials e.g. stone and other materials obtained in the work of dismantling and excavation etc. will be considered Central Warehousing Corporation's property and would be issued to the contractor (if they require the same for use in the work) at the rates approved by the Engineer-in-Charge, as the case may be.

**SECTION – IV**  
**(TENDER FORMS & ANNEXURES)**

## CENTRAL WAREHOUSING CORPORATION

(A GOVT. OF INDIA UNDERTAKING)

Regional Office- LF-10, 4<sup>th</sup> Cross Road, Saraswathipuram, Nandini Layout, Pin -560096.

Corporate Office, 4/1 Siri Institutional Area, August Kranti Marg, Hauz khas, New Delhi

---

### “TENDER & CONTRACT”

#### PERCENTAGE RATE TENDER & CONTRACT FOR WORKS

(A)Tender for the work of “Major repairs and strengthening to Gable walls of Godown No. 2A to avoid differential settlement and remedial measures including Piling at CW gadag-II,( Karnataka)”

(i)To be submitted online Website [www.cwceprocure.com](http://www.cwceprocure.com) by 3.00 PM up to or on 11/03/2021.

(ii)To be opened online Website [www.cwceprocure.com](http://www.cwceprocure.com). in presence of Tenderers or their authorized representative who may wish to be present at 3.30 PM on 11/03/2021 in the office of The REGIONAL MANAGER/ SUPERINTENDING Engineer, Central Warehousing Corporation, Regional Office- LF-10, 4<sup>th</sup> Cross Road, Saraswathipuram, Nandini Layout, Pin -560096.

### TENDER

I/We have read and examined the Tender Notice, Notice Inviting Tender, Schedule A, B, C, D, E & F, specifications applicable, drawings and designs, general rules and directions, conditions of contract, clauses of contract, special conditions, schedule of rate and other documents and rules referred to in the conditions of contract and all other contents in the tender documents for the work.

I/We hereby tender for execution of the work specified for the Central Warehousing Corporation within the time specified in Schedule ‘F’, viz., Schedule of quantities and in accordance in all respects with the specifications, designs, drawings and instructions in writing referred to in Rule 1 of General Rules and Directions and in clause 11 of the General Conditions of Contract and with such materials as are provided for by, and in respects in accordance with such conditions so far as applicable.

I/We agree to keep **the tender open for ninety (90) days from the date of opening of technical bid** under two bid system and not to make any modifications in its terms and conditions.

A sum of Rs \_\_\_\_\_ including GST is hereby submitted **through e-payment gateway of e-procurement as EMD and cost of the tender Rs \_\_\_\_\_** \*. If I/We fail to furnish the prescribed performance guarantee within prescribed period, I/We agree that the Central Warehousing Corporation shall without prejudice to any other right/remedy, be at liberty to forfeit the said earnest money absolutely. Further, if I/We, fail to commence the work as specified, I/We agree that the Central Warehousing Corporation shall without prejudice to any other right or remedy, be at liberty to forfeit the said earnest money and the performance guarantee absolutely, otherwise the said earnest money shall be retained by the Corporation towards security deposit

to execute all the works referred to in the tender documents upon the terms and conditions contained or referred to therein and to carry out such deviations as may be ordered, up to maximum of the percentage mentioned in Schedule 'F' and those in excess of that limit at the rates to be determined in accordance with the provisions contained in Clause 12.2 and 12.3 of the tender form. Further, I/We agree that in case of forfeiture of earnest money or both Earnest Money and Performance Guarantee as aforesaid, I/We shall be debarred for participation in the re-tendering process of the work.

"I/we undertake and confirm that eligible similar work(s) has/have not been got executed through another contractor on back to back basis. Further that, if such a violation comes to the notice of Department, then I/we shall be debarred for tendering in CWC in future forever. Also, if such a violation comes to the notice of Department before date of start of work, the Engineer-in-charge shall be free to forfeit the entire amount of Earnest Money Deposit/Performance Guarantee."

I/We hereby declare that I/We shall treat tender documents, drawings and other records connected with the work as secret / confidential documents and shall not communicate information/ derived there from to any person other than a person to whom I/We am/are authorized to communicate the same or use the information in any manner pre-judicial to the safety of the Corporation.

Dated \_\_\_\_\_

**Signature of Contractor**  
**Postal Address**

Witness:

Address:

Occupation:

\* Cost of the tender to be deposited along with the EMD would be applicable only to those contractors who will download the tenders from the websites as mentioned in the NIT.

### ACCEPTANCE

The above tender (as modified by you as provided in the letters mentioned hereunder) is accepted by me for and on behalf of Central Warehousing Corporation for a sum of Rs. \_\_\_\_\_ (Rupees \_\_\_\_\_) i.e. \_\_\_\_\_ % above/below the estimated cost of work of Rs. \_\_\_\_\_ (Rupees \_\_\_\_\_)

The letters referred to below shall form part of this contract agreement.

- a) \_\_\_\_\_
- b) \_\_\_\_\_
- c) \_\_\_\_\_

Dated:

**For & on behalf of CWC**

**Signature** \_\_\_\_\_

**Designation** \_\_\_\_\_

FORMAT OF NET WORTH

A. The Net Worth of Mr./Ms./M/s \_\_\_\_\_ for last Financial Year \_\_\_\_\_ is Rs. \_\_\_\_\_ lakhs as per his/her/their books of Accounts.

(Note: Net Worth means sum total of paid up share capital plus free reserves. Further any debit balance of Profit and Loss Account and Misc. Expenses to the extent not adjusted / or written off, if any, shall be reduced from Reserves and Surpluses.

Signature of Chartered Accountant

Name:

Membership No.:

**Signature of Contractor**

Seal:

Date:

**AFFIDAVIT  
(For Sole Proprietary Firm)**

**(To be executed in presence of Public Notary on non- judicial stamp paper of appropriate value. The stamp paper has to be in the name of the tenderer.)**

I, .....R/o .....  
..... do hereby solemnly affirm and declare as under :-

- 1. That I am Sole Proprietor of ..... (Sole Proprietor Firm Name)
- 2. That the office of the firm is situated at .....

Place: DEPONENT

Date:

**VERIFICATION**

Verified that the contents of my above said affidavit are true and correct to the best of my knowledge and belief and nothing has been concealed there from.

Place: DEPONENT

Date:

**FORMAT FOR POWER OF ATTORNEY TO AUTHORIZED SIGNATORY**

**POWER OF ATTORNEY**

(To be executed on non-judicial stamp paper of the appropriate value in accordance with relevant Stamp Act. The stamp paper to be in the name of the firm/ company who is issuing the Power of Attorney).

We, M/s. \_\_\_\_\_ (name of the firm/ company with address of the registered office) hereby constitute, appoint and authorize Mr./Ms. \_\_\_\_\_ (Name and residential address) who is presently with us and holding the position of \_\_\_\_\_ and whose signature is given below as our Attorney to do in our name and our behalf all or any of the acts, deeds or things necessary or incidental to our bid for the work \_\_\_\_\_ (name of work), including signing and submission of application/ tender / proposal, participating in the meetings, responding to queries, submission of information/ documents and generally to represent us in all the dealings with CWC or any other Government Agency or any person, in connection with the works until culmination of the process of bidding, till the Contract Agreement is entered into with CWC and thereafter till the expiry of the Contact Agreement.

We hereby agree to ratify all acts, deeds and things lawfully done by our said Attorney pursuant to this Power of Attorney and that all acts, deeds and things done by our aforesaid Attorney shall always be deemed to have been done by us.

Dated this the \_\_\_\_\_ day of \_\_\_\_\_ 20

(Signature and name of authorized signatory being given Power of Attorney)

\_\_\_\_\_

**(Signature and name in block letters of Proprietor / All the partners of the firm / Authorized Signatory for the Company) (Strike out whichever is not applicable)**

Seal of the Proprietorship firm / Partnership firm/ Company

Witness 1:

Name:

Address:

Occupation:

Witness 2:

Name:

Address:

Occupation:

**Notes:**

- The mode of execution of the power of Attorney should be in accordance with the procedure, if any, laid down by the applicable law and the charter documents of the executants (s) and when it is so required the same should be under common seal affixed in accordance with the required procedure.

- Power of Attorney is to be attested by Notary.

## ANNEXURE-IV

### AFFIDAVIT

#### **(FORMAT FOR AFFIDAVIT TO BE SUBMITTED BY TENDERER ALONGWITH THE TENDER DOCUMENTS)**

**(To be executed in presence of Public Notary on non- judicial stamp paper of the value of Rs. 100/-. The stamp paper has to be in the name of the tenderer.)**

I \_\_\_\_\_ (Name and designation) \_\_\_\_\_ appointed as the attorney/ authorized signatory of the tenderer (including its constituents), M/s. \_\_\_\_\_ (hereinafter called the tenderer) for the purpose of the Tender documents for the work of \_\_\_\_\_ as per the Tender No. \_\_\_\_\_ of CWC, do hereby solemnly affirm and State on behalf of the tenderer including its constituents as under:

1. I/ We the tenderer (s), am/ are signing this document after carefully reading the contents.
2. I/ We the tenderer (s) also accept all the conditions of the tender document and have signed all the pages in confirmation thereof.
3. I/ We hereby declare that I/We have downloaded the tender documents from CWC tender portal [www.cwceprocure.com](http://www.cwceprocure.com) and printed the same. I/We have verified the content of the printed document from the website and there is no addition, no deletion or no alteration to the content of the tender document. In case of any discrepancy noticed at any stage (i.e. evaluation of tenders & execution of work) the decision of CWC with regard to such discrepancies shall be final and binding upon me/us.
4. I/We declare and certify that I/we have not made any misleading or false representation in the forms, statements and attachments in proof of the qualification requirements.
5. **I/We also understand that my/our offer will be evaluated based on the documents/credentials submitted along with the offer and same shall be binding upon me/us.**

**I/We declare that the information and documents submitted along with the tender by me/us are correct and I/We are fully responsible for the correctness of the information and documents, submitted by us.**

6. I/We understand that if the certificates regarding eligibility criteria, submitted by us are found to be forged/ false or incorrect at any time during process for evaluation of tenders, it shall lead to forfeiture of the tender EMD besides suspending of business for minimum one year. Further, I/We \_\_\_\_\_ [insert name of the tenderer] \_\_\_\_\_ and all my/our constituents understand that my/our offer shall be summarily rejected.
7. I/ We also understand that if the certificates submitted by us are found to be false/forged or incorrect at any time, after the award of the contract, it will lead to termination of the contract, along with forfeiture of EMD/ SD and Performance Guarantee besides any other action provided in the contract.
8. I/We certify that I/We are not black listed or debarred by MES/CPWD/Railways /any Govt. Department / State PWDs/ PSU (Public Sector Undertaking) and Govt. Sector Construction Agencies from participation in tenders/contract on the date of opening of bids.

**DEPONENT**



**SEAL AND SIGNATURE OF THE TENDERER**

VERIFICATION

I/We above named tenderer do hereby solemnly affirm and verify that the contents of my/ our above affidavit are true and correct. Nothing has been concealed and no part of it is false.

**DEPONENT**

**SEAL AND SIGNATURE  
OF THE TENDERER**

**Place:-**

**Dated:-**

**Details as appropriate are to be filled in suitably by tenderer.**

**Attestation before Magistrate/ Notary Public.**

**PRE CONTRACT INTEGRITY PACT****General**

This pre-bid/pre-contract Agreement (hereinafter called the Integrity Pact) is made on \_\_\_\_\_ day of the month of \_\_\_\_\_ between on one hand, the Central Warehousing Corporation (A Govt. of India Undertaking), 4/1 Siri Institutional area, Hauz Khas, New Delhi, acting through Chief Engineer/ Superintending Engineer, Central Warehousing Corporation (A Govt. of India Undertaking) (hereinafter called the "CORPORATION" which expression shall mean and include, unless the context otherwise requires, his successors in office and assigns) of the First Part and M/s \_\_\_\_\_ represented by Shri \_\_\_\_\_, (Name of the contractor) (hereinafter called TENDERER which expression shall mean and include, unless the context otherwise requires, his successors and permitted assigns) of the Second Part.

WHEREAS the CORPORATION proposes to Construct ----- MTC Godowns along with -----at and the TENDERER is willing to execute the items of work /Section as per schedule of work, the work order issued, General conditions of the contract of CWC and CPWD specifications.

WHEREAS the TENDERER is a private company/public company/Government undertaking/partnership firm constituted in accordance with the relevant law in the matter and the corporation is a PSU performing its functions on behalf of the Ministry of Consumer Affairs, Food and Public Distribution, New Delhi, Govt. of India.

NOW, THEREFORE,

To avoid all forms of corruption by following a system that is fair, transparent and free from any influence/prejudiced dealings prior to, during and subsequent to the currency of the contract to be entered into with a view to:-

Enabling the CORPORATION to obtain the desired said work at a competitive price in conformity with the defined specifications by avoiding the high cost and the distortionary impact of corruption on public procurement, and

Enabling TENDERER to abstain from bribing or indulging in any corrupt practice in order to secure the contract by providing assurance to them that their competitors will also abstain from bribing and other corrupt practices and the CORPORATION will commit to prevent corruption, in any form, by its officials by following transparent procedures.

The parties hereto hereby agree to enter into this integrity Pact and agree as follows:

1. **Commitments of the Corporation**

1.1 The Corporation undertakes that no official of the CORPORATION, connected directly or indirectly with the contract, will demand, take a promise for or accept, directly or through intermediaries, any bribe, consideration, gift, reward, favour or any material or immaterial benefit or any other advantage from the TENDERER, either for themselves or for any person, organisation or third party related to the contract in exchange for an advantage in

the bidding process, bid evaluation, contracting or implementation process related to the contract.

- 1.2 The CORPORATION will, during the pre-contractor stage, treat all TENDERERS alike and will provide to all TENDERERS the same information and will not provide any such information to any particular TENDERER which could afford an advantage to that particular TENDERER in comparison to other TENDERERS.
- 1.3 All the officials of the CORPORATION will report to the appropriate authority any attempted or completed breaches of the above commitments as well as any substantial suspicion of such a breach.

2. In case any such preceding misconduct on the part of such official(s) is reported by the TENDERER to the CORPORATION with full and verifiable facts and the same is prima facie found to be correct by the CORPORATION, necessary disciplinary proceedings, or any other action as deemed fit, including criminal proceedings may be initiated by the CORPORATION and such a person shall be debarred from further dealings related to the contract process. In such a case while an enquiry is being conducted by the CORPORATION the proceedings under the contract would not be stalled.

### 3. **Commitments of TENDERERS**

The TENDERER commits itself to take all measures necessary to prevent corrupt practices, unfair means and illegal activities during any stage of its bid or during any pre-contract or post-contract stage in order to secure the contract or in furtherance to secure it and in particular commit itself to the following:-

- 3.1 The TENDERER will not offer, directly or through intermediaries, any bribe, gift, consideration, reward, favour, any material or immaterial benefit or other advantage, commission, fees, brokerage or inducement to any official of the CORPORATION, connected directly or indirectly with the bidding process, or to any person, organisation or third party related to the contract in exchange for any advantage in the bidding, evaluation, contracting and implementation of the contract.
- 3.2 The TENDERER further undertakes that it has not given, offered or promised to give, directly or indirectly any bribe, gift, consideration, reward, favour, any material or immaterial benefit or other advantage, commission, fees, brokerage or inducement to any official of the CORPORATION or otherwise in procuring the Contract or forbearing to do or having done any act in relation to the obtaining or execution of the contract or any other contract with the CORPORATION for showing or forbearing to show favour or disfavour to any person in relation to the contract or any other contract with the CORPORATION.
- 3.3 The TENDERER, either while presenting the bid or during pre-contract negotiations or before signing the contract, shall disclose any payments he has made, is committed to or intends to make to officials of the CORPORATION or their family members, agents, brokers or any other intermediaries in connection with the contract and the details of services agreed upon for such payments.
- 3.4 The TENDERER will not collude with other parties interested in the contract to impair the transparency, fairness and progress of the bidding process, bid evaluation, contracting and implementation of the contract.
- 3.5 The TENDERER will not accept any advantage in exchange for any corrupt practice, unfair means and illegal activities.

- 3.6 The TENDERER shall not use improperly, for purposes of competition or personal gain, or pass on to others, any information provided by the CORPORATION as part of the business relationship, regarding plans, technical proposals and business details, including information contained in any electronic data carrier. The TENDERER also undertakes to exercise due and adequate care lest any such information is divulged.
- 3.7 The TENDERER commits to refrain from giving any complaint directly or through any other manner without supporting it with full and verifiable facts.
- 3.8 The TENDERER shall not instigate or cause to instigate any third person to commit any of the actions mentioned above.
- 3.9 If the TENDERER or any employee of the TENDERER or any person acting on behalf of the TENDERER, either directly or indirectly, is a relative of any of the officers of the CORPORATION, or alternatively, if any relative of an officer of the CORPORATION has financial interest/stake in the TENDERER's firm, the same shall be disclosed by the TENDERER at the time of filling of tender.  
The term 'relative' for this purpose would be as defined in Section 6 of the Companies Act 1956
- 3.10 The TENDERER shall not lend to or borrow any money from or enter into any monetary dealings or transactions, directly or indirectly, with any employee of the CORPORATION

#### 4. **Previous Transgression**

- 4.1 The TENDERER declares that no previous transgression occurred in the last three years immediately before signing of this Integrity Pact, with any other company in any country in respect of any corrupt practices envisaged hereunder or with any Public Sector Enterprise in India or any Government Department in India that could justify TENDERER's exclusion from the tender process.
- 4.2 The TENDERER agrees that if it makes incorrect statement on this subject, TENDERER can be disqualified from the tender process or the contract, if already awarded, can be terminated for such reason.

#### 5. **Earnest Money (Security Deposit)**

- 5.1 While submitting Technical bid, the TENDERER shall deposit an amount of Rs. \_\_\_\_\_ (to be specified in NIT) as Earnest Money, with the CORPORATION **only through e-payment gateway of e-procurement system.**
- 5.2 The Earnest Money/Security Deposit and performance guarantee shall be valid for the period as per the relevant terms & condition of the contract
- 5.3 No interest shall be payable by the CORPORATION to the TENDERER on Earnest Money/Security Deposit/performance guarantee for the period of its currency and upto their validity.

## 6. Sanctions for Violations

Any breach of the aforesaid provision by the TENDERER or any one employed by it or acting on its behalf (whether with or without the knowledge of the TENDERER) shall entitle the CORPORATION to take all or any one of the following actions, wherever required:-

- (i) To immediately call off the pre-contract negotiations without assigning any reason or giving any compensation to the TENDERER. However, the proceedings with the other TENDERER(s) would continue.
- (ii) The Earnest Money Deposit (in pre-contract stage) and/or Security Deposit/Performance Bond (after the contract is signed) shall stand forfeited either fully or partially, as decided by the CORPORATION and the CORPORATION shall not be required to assign any reason therefore.
- (iii) To immediately cancel the contract, if already signed, without giving any compensation to the TENDERER.
- (iv) To recover all sums already paid by the CORPORATION, and in case of an Indian TENDERER with interest thereon at 2% higher than the prevailing Prime Lending Rate of State Bank of India, while in case of a TENDERER from a country other than India with interest thereon at 2% higher than the LIBOR. If any outstanding payment is due to the TENDERER from the CORPORATION in connection with any other contract for any other stores/work such outstanding payment could also be utilized to recover the aforesaid sum and interest.
- (v) To encash the advance bank guarantee and performance bond/warranty bond, if furnished by the TENDERER, in order to recover the payments, already made by the CORPORATION, along with interest.
- (vi) To cancel all or any other Contracts with the TENDERER. The TENDERER shall be liable to pay compensation for any loss or damage to the CORPORATION resulting from such cancellation/rescission and the CORPORATION shall be entitled to deduct the amount so payable from the money(s) due to the TENDERER.
- (vii) To debar the TENDERER from participating in future bidding processes of the CORPORATION for a minimum period of five years, which may be further extended at the discretion of the CORPORATION.
- (viii) To recover all sums paid in violation of this Pact by TENDERER(s) to any middleman or agent or broker with a view to securing the contract.
- (ix) In cases where irrevocable Letters of Credit have been received in respect of any contract signed by the CORPORATION with the TENDERER, the same shall not be opened.,
- (x) Forfeiture of Performance Bond in case of a decision by the CORPORATION to forfeit the same without assigning any reason for imposing sanction for violation of this Pact.

The CORPORATION will be entitled to take all or any of the actions mentioned at para 6.1(i) to (x) of this Pact also on the Commission by the TENDERER or any one employed by it or acting on its behalf (whether with or without the knowledge of the TENDERER), of an offence as defined in Chapter IX of the Indian Penal code, 1860 or Prevention of Corruption Act, 1988 or any other statute enacted for prevention of corruption.

The decision of the CORPORATION to the effect that a breach of the provisions of this Pact has been committed by the TENDERER shall be final and conclusive on the TENDERER. However, the TENDERER can approach the independent Monitor(s) appointed for the purposes of this Pact.

7. **Fall Clause**

The TENDERER undertakes that it has not supplied/is not supplying similar product/systems or subsystems at a price lower than that offered in the present bid in respect of any other Ministry/Department of the Government of India or PSU and if it is found at any stage that similar product/systems or sub systems was supplied by the TENDERER to any other Ministry/Department of the Government of India or a PSU at a lower price, then that very price, with due allowance for elapsed time, will be applicable to the present case and the difference in the cost would be refunded by the TENDERER to the CORPORATION, if the contract has already been concluded.

8. **Independent Monitor**

The CORPORATION has appointed Sh. Shahnawaz Ali, Flat No.-301, SMR's OosmanVinay Heights, Keshav Nagar, Mettuguda, Secunderabad-500017, Telangana an Independent Monitor (hereinafter referred to as Monitor) for this Pact in consultation with the Central Vigilance Commission.

The task of the Monitor shall be to review independently and objectively, whether and to what extent the parties comply with the obligations under this Pact.

The Monitor shall not be subject to instructions by the representatives of the parties and perform their functions neutrally and independently.

Both the Parties accept that the monitors have the right to access all the documents relating to the project/procurement, including minutes of meetings.

As soon as the Monitor notices, or has reason to believe, a violation of this Pact, he will so inform the Authority designated by the CORPORATION.

The TENDERER(s) accepts that the Monitor has the right to access without restriction to all Project documentation of the CORPORATION including that provided by the TENDERER. The TENDERER will also grant the Monitor, upon his request and demonstration of a valid interest, unrestricted and unconditional access to his project documentation. The same is applicable to Subcontractors. The Monitor shall be under contractual obligation to treat the information and documents of the TENDERER/Subcontractor(s) with confidentiality.

The CORPORATION will provide to the Monitor sufficient information about all meetings among the parties related to the Project provided such meetings could have an impact on the contractual relations between the parties. The parties will offer to the Monitor the option to participate in such meetings.

The Monitor will submit a written report to the designated Authority of CORPORATION within 8 to 10 weeks from the date of reference or intimation to him by the CORPORATION / TENDERER and, should the occasion arise, submit proposals for correcting problematic situations.

9. **Facilitation of Investigation**

In case of any allegation of violation of any provisions of this Pact or payment of commission, the CORPORATION or its agencies shall be entitled to examine all the documents including the Books of Accounts of the TENDERER and the TENDERER shall provide necessary information and documents in English and shall extend all possible help for the purpose of such examination.

10. **Law and Place of Jurisdiction**

This Pact is subject to Indian Law. The Place of performance and jurisdiction is the seat of the CORPORATION.

11. **Other Legal Actions**

The actions stipulated in this integrity Pact are without prejudice to any other legal action that may follow in accordance with the provisions of the extant law in force relating to any civil or criminal proceedings.

12. **Validity**

The validity of this Integrity Pact shall be from date of its signing and extend upto 5 years or the complete execution of the contract to the satisfaction of both the CORPORATION and the TENDERER/Seller, including warranty period, whichever is later. In case TENDERER is unsuccessful, this integrity Pact shall expire after six months from the date of the signing of the contract.

Should one or several provisions of this Pact out to be invalid; the remainder of this Pact shall remain valid. In this case, the parties will strive to come to an agreement to their original intentions.

13. The parties hereby sign this Integrity Pact at \_\_\_\_\_ on \_\_\_\_\_

CORPORATION  
Name of the Officer  
Designation

SIGNATURE OF TENDERER

Witness  
1. \_\_\_\_\_

Witness  
1. \_\_\_\_\_

2. \_\_\_\_\_

2. \_\_\_\_\_

**COMPLIANCE TO BID REQUIREMENT**

We hereby confirm that we have gone through and understood the Tender Document and our bid complies with the requirements / terms and conditions of the Tender Document and subsequent addendum / corrigendum (if any), issued by CWC, without any deviation / exception / comments / assumptions.

We also confirm that we have quoted the rates without any condition and deviation.

The Tender has been submitted along with the required documents and same have been uploaded under digital signatures of the authorized signatory. We undertake that the tender document shall be deemed to be our bid and in the event of award of work to us, the same shall be considered for constitution of contract agreement. Further, we shall sign and stamp each page of the Tender Document as token of acceptance and as part of contract in the event of award of contract to us.

We further confirm that we have quoted our rates in our financial bid as per the conditions of the Tender Document and for all the items.

**Stamp and signature of the TENDERER:** \_\_\_\_\_

**Name of the TENDERER** : \_\_\_\_\_

**NOTE: To be stamped and signed by the authorized signatory who is signing the Bid and submitted along with the Technical Bid.**



**CENTRAL WAREHOUSING CORPORATION  
(A GOVT. OF INDIA UNDERTAKING)**

**Agreement For Item / Percentage Rates For Works**

This Agreement for execution of work executed at \_\_\_\_\_ this day of the \_\_\_\_\_ 200 by the Central Warehousing Corporation, New Delhi- 16 established under Warehousing Corporation Act, 1962 (hereinafter called 'the' Corporation) and M/S \_\_\_\_\_ a partnership firm from consisting of partners namely (i) \_\_\_\_\_ (ii) \_\_\_\_\_ (iii) \_\_\_\_\_/company registered under companies Act/individual carrying on business in the name and style of \_\_\_\_\_ (herein under called "contractor" which term shall mean and include unless repugnant to the context his/ their executors. Administrators, legal and personal representatives Witnesses as follows:

WHEREAS the Corporation requires \_\_\_\_\_ to be constructed at \_\_\_\_\_ and whereas the contractor has agreed to execute the items of work Section as per General Conditions of Contract and Schedule of Work attached.

AND WHEREAS the contractor having agreed to execute the above referred items of works/ Section it is hereby agreed that the terms and conditions of the contract as enumerated in General Conditions of Contract (Broad Heading of which are given in the Index thereto) item of works/ section as per Schedule of work, the work order issued and specification of the CPWD for the time being enforce shall form an integral part sole repository of the terms and conditions of this contract.

In witness where of the aforementioned parties to the contract have affixes their signatures.

Contractor  
Witness & address

For and on behalf of the Corporation  
Witness & address

1.  
Dt.

1.  
Dt.

2.  
Dt.

2.  
Dt.

## ANNEXURE-VIII

### Form of Performance Security Bank Guarantee Bond

In consideration of Central Warehousing Corporation (A Govt. of India Undertaking) Warehousing Bhawan, 4/1 Siri Institutional Area, August Kranti Marg, Hauz Khas, New Delhi -110 016 (hereinafter called "The Corporation") having offered to accept the Letter of Acceptance (LOA). no. \_\_\_\_\_ dated \_\_\_\_\_ and the terms and conditions of the proposed agreement between Corporation and \_\_\_\_\_ (hereinafter called "the said contractor(s)") for the work of \_\_\_\_\_ (hereinafter called "the said agreement") having agreed to production of an irrevocable Bank Guarantee for Rs. \_\_\_\_\_ (Rupees \_\_\_\_\_ only) as a security/guarantee from the contractor(s) for compliance of his obligations in accordance with the terms and conditions in the said agreement.

We \_\_\_\_\_ (hereinafter referred to as "the Bank") hereby undertake to pay (Indicate the name of the Bank) Corporation an amount not exceeding Rs. \_\_\_\_\_ (Rupees \_\_\_\_\_ only) on demand by the Corporation

1. We \_\_\_\_\_ do hereby undertake to pay the amounts due and payable under (indicate the name of the Bank) Guarantee without any demure, merely on a demand from the Corporation stating that the amount claimed is required to meet the recoveries due or likely to be due from the said contractor(s). Any such demand made on the Bank shall be conclusive as regards the amount due and payable by the bank under this Guarantee. However, our liability under this guarantee shall be restricted to an amount not exceeding Rs. \_\_\_\_\_ (Rupees \_\_\_\_\_ only).
2. We, the said bank further undertake to pay to the Corporation any money so demanded notwithstanding any dispute or disputes raised by the contractor(s) in any suit or proceeding pending before any court or Tribunal relating thereto, our liability under this present being absolute and unequivocal. The payment so made by us under this bond shall be valid discharge of our liability for payment there under, and the contractors (s) shall have no claim against us for making such payment.
3. We \_\_\_\_\_ further agree that the guarantee herein contained shall remain in (indicate the name of the bank) and effect during the period that would be taken for the performance of the said agreement and that it shall continue to be enforceable till all the dues of the Corporation under or by virtue of the said agreement have been fully paid and its claim satisfied or discharged or till Engineer-in-Charge on behalf of the Corporation certified that the terms and conditions of the said agreement have been fully and properly carried out by the said contractor (s) and accordingly discharges this guarantee.
4. We \_\_\_\_\_ further agree with the Central Warehousing Corporation that the (indicate the name of the bank)

Corporation shall have the fullest liberty without our consent and without effecting in any manner our obligations hereunder to vary any of the terms and conditions of the said agreement or to extend time of performance by the said contractor(s) from time to time or to postpone for any time or from time to time any of the powers exercisable by the Central Warehousing Corporation against the said contractor(s) and to forbear or enforce any of the terms and conditions relating to the said agreement and we shall not be relieved from our liability by reason of any such variation, or extension being granted to the said contractor (s) or for any forbearance, act if omission on the part of the Central Warehousing Corporation or any indulgence by the Central Warehousing Corporation to the said contractor (s) or by any such matter or things whatsoever which under the law relating to sureties would, but for this provision, have effect of so relieving us.

5. This guarantee will not be discharged due to the change in the constitution of the bank or the contractor (s)

6. We \_\_\_\_\_ lastly undertake not to revoke this guarantee except with the  
(indicate the name of the bank)  
previous consent of the Central Warehousing Corporation in writing.

7. This guarantee shall be valid up to \_\_\_\_\_. Unless extended on demand by Central Warehousing Corporation. Notwithstanding anything mentioned above, our liability against this guarantee is restricted to Rs. \_\_\_\_\_  
(Rs. \_\_\_\_\_ only) and unless a claim in writing is lodged with us within six months of the date of expiry or the extended date of expiry of this guarantee, all our liabilities under this guarantee shall stand discharged

Dated the \_\_\_\_\_ date of \_\_\_\_\_ for

\_\_\_\_\_  
(Indicate the name of bank)

## ANNEXURE-IX

### AFFIDAVIT

(To be submitted by bidder on non-judicial stamp paper of minimum value of Rs.100/- along with their Tender)

I/We undertake and confirm that eligible similar work(s) has/have not been got executed through another contractor on back to back basis. Further that, if such a violation comes to the notice of Department, then I/We shall be debarred for tendering in CWC in future forever. Also, if such a violation comes to the notice of Department before date of start of work, the Engineer-in-Charge shall be free to forfeit the entire amount of Earnest Money Deposit / Performance Guarantee. (scanned copy of this affidavit to be uploaded at the time of submission of tender).

Signature of Tenderer  
Postal Address  
Stamp

Witness:  
Address:  
Occupation

**Section-V**  
**GENERAL CONDITIONS OF CONTRACT**  
**(CPWD CONDITIONS OF CONTRACT)**

**ERRATA**

<b>Clause No.</b>	<b>Description</b>
<b>Clause 2A, 10B (ii), (iii), (iv), (v), 10 C, 10CA, 10CC</b>	<b>Deleted</b>

**CENTRAL WAREHOUSING CORPORATION  
(A Govt. of India Undertaking)**

**General Rules & Directions**

**General  
Rules &  
Directions**

1. All work proposed for execution by contract will be notified in a form of invitation to tender pasted in public places and signed by the officer inviting tender or by publication in Newspapers or posted on website as the case may be.

This form will state the work to be carried out, as well as the date for submitting and opening tenders and the time allowed for carrying out the work, also the amount of earnest money to be deposited with the tender, and the amount of the security deposit and Performance guarantee to be deposited by the successful tenderer and the percentage, if any, to be deducted from bills. Copies of the specifications, designs and drawings and any other documents required in connection with the work signed for the purpose of identification by the officer inviting tender shall also be open for inspection by the contractor at the office of officer inviting tender during office hours.

2. In the event of the tender being submitted by a firm, it must be signed separately by each partner thereof or in the event of the absence of any partner, it must be signed on his behalf by a person holding a power-of attorney authorizing him to do so, such power of attorney to be produced with the tender, and it must disclose that the firm is duly registered under the Indian Partnership Act, **1932**.

3. Receipts for payment made on account of work, when executed by a firm, must also be signed by all the partners, except where contractors are described in their tender as a firm, in which case the receipts must be signed in the name of the firm by one of the partners, or by some other person having due authority to give effectual receipts for the firm.

**Applicable for  
Item Rate  
Tender only**

4. Any person who submits a tender shall fill up the usual printed form, stating at what rate he is willing to undertake each item of the work. Tenders, which propose any alteration in the work specified in the said form of invitation to tender, or in the time allowed for carrying out the work, or which contain any other conditions of any sort, including conditional rebates, will be summarily rejected. No single tender shall include more than one work, but contractors who wish to tender for two or more works shall submit separate tender for each. Tender shall have the name and number of the works to which they refer, written on the envelopes.

The rate(s) must be quoted in decimal coinage. Amounts must be quoted in full rupees by ignoring fifty paisa and considering more than fifty paisa as rupee one.

In case the lowest tendered amount (worked out on the basis of quoted rate of

Individual items) of two or more contractors is same, then such lowest contractors may be asked to submit sealed revised offer quoting rate of each item of the schedule of quantity for all sub sections/sub heads as the case may be, but the revised quoted rate of each item of schedule of quantity for all sub sections/sub heads should not be higher than their respective original rate quoted already at the time of submission of tender. The lowest tender shall be decided on the basis of revised offer.

If the revised tendered amount (worked out on the basis of quoted rate of individual items) of two or more contractors received in revised offer is again found to be equal, then the lowest tender, among such contractors, shall be decided by draw of lots in the presence of Tender Evaluation Committee and the lowest contractors those have quoted equal amount of their tenders.

In case of any such lowest contractor in his revised offer quotes rate of any item more than their respective original rate quoted already at the time of submission of tender, then such revised offer shall be treated invalid. Such case of revised offer of the lowest contractor or case of refusal to submit revised offer by the lowest contractor shall be treated as withdrawal of his tender before acceptance and 50% of his earnest money shall be forfeited.

In case all the lowest contractors those have same tendered amount (as a result of their quoted rate of individual items), refuse to submit revised offers, then tenders are to be recalled after forfeiting 50% of EMD of each lowest contractors.

Contractor, whose earnest money is forfeited because of non-submission of revised offer, or quoting higher revised rate(s) of any item(s) than their respective original rate quoted already at the time of submission of his bid shall not be allowed to participate in the retendering process of the work.

**Applicable for  
Percentage  
Rate  
Tender only**

4 A. Applicable for Percentage Rate Tender only

In case of Percentage Rate Tenders, contractor shall fill up the usual printed form, stating at what percentage below/above (in figures as well as in words) the total estimated cost given in Schedule of Quantities at Schedule-A, he will be willing to execute the work. The tender submitted shall be treated as invalid if: -

1. The contractor does not quote percentage above/ below on the total amount of tender or any section/ sub head of the tender.
2. The percentage above/below is not quoted in figures & words both on the total amount of tender or any section/ sub head of the tender.
3. The percentage quoted above/below is different in figures & words on the total amount of tender or any section/ sub head of the tender.

Tenders, which propose any alteration in the work specified in the said form of invitation to tender, or in the time allowed for carrying out the work, or which contain



any other conditions of any sort including conditional rebates, will be summarily rejected. No single tender shall include more than one work, but contractors who wish to tender for two or more works shall submit separate tender for each. Tender shall have the name and number of the works to which they refer, written on the envelopes.

4B. In case the lowest tendered amount (estimated cost + amount worked on the basis of percentage above/below) of two or more contractors is same, such lowest contractors will be asked to submit sealed revised offer in the form of letter mentioning percentage above/ below on estimated cost of tender including all sub sections/sub heads as the case may be, but the revised percentage quoted above/below on tendered cost or on each sub section/ sub head should not be higher than the percentage quoted at the time of submission of tender. The lowest tender shall be decided on the basis of revised offers.

In case any of such contractor refuses to submit revised offer, then it shall be treated as withdrawal of his tender before acceptance and 50% of earnest money shall be forfeited.

If the revised tendered amount of two more contractors received in revised offer is again found to be equal, the lowest tender, among such contractors, shall be decided by draw of lots in the presence of Tender Evaluation Committee and the lowest contractors those have quoted equal amount of their tenders.

In case all the lowest contractors those have quoted same tendered amount, refuse to submit revised offers, then tenders are to be recalled after forfeiting 50% of EMD of each contractor.

Contractor(s), whose earnest money is forfeited because of non-submission of revised offer, shall not be allowed to participate in the re-tendering process of the work.

5. The officer inviting tender or his duly authorized assistant, will open tenders in the presence of any intending contractors who may be present at the time, and will enter the amounts of the several tenders in a comparative statement in a suitable form. In the event of a tender being accepted, a receipt for the earnest money shall thereupon be given to the contractor who shall thereupon for the purpose of identification sign copies of the specifications and other documents mentioned in Rule-I. In the event of a tender being rejected, the earnest money shall thereupon be returned to the contractor remitting the same, without any interest.

6. The officer inviting tenders shall have the right of rejecting all or any of the tenders and will not be bound to accept the lowest or any other tender.

7. The receipt of an accountant or clerk for any money paid by the contractor will not be considered as any acknowledgment or payment to the officer inviting tender and the contractor shall be responsible for seeing that he procures a receipt signed by the officer inviting tender or a duly authorized Cashier.

8. The memorandum of work tendered for and the schedule of materials to be supplied by the department and their issue-rates, shall be filled and completed in the office of the officer inviting tender before the tender form is issued. If a form is issued to an intending tenderer without having been so filled in and incomplete, he shall request the officer to have this done before he completes and delivers his tender.

9. The tenderers shall sign a declaration under the officials Secret Act 1923, for maintaining secrecy of the tender documents drawings or other records connected with the work given to them. The unsuccessful tenderers shall return all the drawings given to them.

9A Use of correcting fluid, anywhere in tender document is not permitted. Such tender is liable for rejection.

**Applicable for  
Item Rate  
Tender only**

10. In the case of Item Rate Tenders, only rates quoted shall be considered. Any tender containing percentage below/above the rates quoted is liable to be rejected. Rates quoted by the contractor in item rate tender in figures and words shall be accurately filled in so that there is no discrepancy in the rates written in figures and words. However, if a discrepancy is found, the rates which correspond with the amount worked out by the contractor shall unless otherwise proved be taken as correct. If the amount of an item is not worked out by the contractor or it does not correspond with the rates written either in figures or in words, then the rates quoted by the contractor in words shall be taken as correct. Where the rates quoted by the contractor in figures and in words tally, but the amount is not worked out correctly, the rates quoted by the contractor will unless otherwise proved be taken as correct and not the amount. In event no rate has been quoted for any item(s), leaving space both in figure(s), word(s), and amount blank, it will be presumed that the contractor has included the cost of this/these item(s) in other items and rate for such item(s) will be considered as zero and work will be required to be executed accordingly.

**However, if a tenderer quotes nil rates against each item in Item rate tender, the tender shall be treated as invalid and will not be considered as lowest tenderer.**

**Applicable for  
Percentage  
Rate  
Tender only**

10 A. In case of Percentage Rate Tenders only percentage quoted shall be considered. Any tender containing item rates is liable to be rejected. Percentage quoted by the contractor in percentage rate tender shall be accurately filled in figures and words, so that there is no discrepancy.

11. In the case of any tender where unit rate of any item/items appear unrealistic, such tender will be considered as unbalanced and in case the tenderer is unable to provide satisfactory explanation, such a tender is liable to be disqualified and rejected.

**Applicable for Item Rate Tender only** 12. All rates shall be quoted on the tender form. The amount for each item should be worked out and requisite totals given. Special care should be taken to write the rates in figures as well as in words and the amount in figures only, in such a way that interpolation is not possible. The total amount should be written both in figures and in words. In case of figures, the word 'Rs.' should be written before the figure of rupees and word 'P' after the decimal figures, e.g. 'Rs. 2.15 P' and in case of words, the word, 'Rupees' should precede and the word 'Paise' should be written at the end. Unless the rate is in whole rupees and followed by the word 'only' it should invariably be up to two decimal places. While quoting the rate in schedule of quantities, the word 'only' should be written closely following the amount and it should not be written in the next line.

**Applicable for percentage Rate Tender only** 12 A. In Percentage Rate Tender, the tenderer shall quote percentage below/above (in figures as well as in words) at which he will be willing to execute the work. He shall also work out the total amount of his offer and the same should be written in figures as well as in words in such a way that no interpolation is possible. In case of figures, the word 'Rs.' should be written before the figure of rupees and word 'P' after the decimal figures, e.g. 'Rs. 2.15P' and in case of words, the word 'Rupees' should precede and the word 'Paisa' should be written at the end.

13.(i) The Contractor whose tender is accepted, will be required to furnish performance guarantee of 5% (Five Percent) of the tendered amount within the period specified in Schedule F. This guarantee shall be in the form of cash (in case guarantee amount is less than Rs.10,000/-) or Deposit at call receipt of any scheduled bank/Banker's cheque of any scheduled bank/Demand Draft of any scheduled bank/Pay order of any scheduled bank (in case guarantee amount is less than Rs. 1,00,000/-) or Government Securities or Fixed Deposit Receipts or Guarantee Bonds of any Scheduled Bank or the State Bank of India in accordance with the prescribed form.

(ii) The contractor whose tender is accepted will also be required to furnish by way of Security Deposit for the fulfilment of his contract, an amount equal to 2.5% of the tendered value of the work. The Security deposit will be collected by deductions from the running bills as well as final bill of the contractor at the rates mentioned above. The Security amount will also be accepted in cash or in the shape of Government Securities. Fixed Deposit Receipt of a Scheduled Bank or State Bank of India will also be accepted for this purpose provided confirmatory advice is enclosed.

14. On acceptance of the tender, the name of the accredited representative(s) of the contractor who would be responsible for taking instructions from the Engineer-in-Charge shall be communicated in writing to the Engineer-in-Charge.

15. **GST** or any other tax applicable in respect of **inputs procured by the contractor** for this contract shall be payable by the Contractor and CWC will not entertain any claim whatsoever in respect of the same.

16. The contractor shall give a list of both gazetted and non-gazetted CWC employees related to him.

17. The tender for the work shall not be witnessed by a contractor or contractors who himself/ themselves has/have tendered or who may and has/have tendered for the same work. Failure to observe this condition would render, tenders of the contractors tendering, as well as witnessing the tender, liable to summary rejection.

18. The tender for composite work includes, in addition to building work, all other works such as sanitary and water supply installations drainage installation, electrical work, horticulture work, roads and paths etc. The tenderer apart from being a registered contractor (B&R) of appropriate class, must associate himself with agencies of appropriate class which are eligible to tender for sanitary and water supply drainage, electrical and horticulture works in the composite tender.

19. The contractor shall submit list of works which are in hand (progress) in the following form:

<b>Name of work</b>	<b>Name and particulars of Deptt. where work is being executed</b>	<b>Value of work</b>	<b>Position of works in progress</b>	<b>Remarks</b>
1.	2.	3.	4.	5.

20. The contractor shall comply with the provisions of the Apprentices Act 1961, and the rules and orders issued there under from time to time. If he fails to do so, his failure will be a breach of the contract and the Chief Engineer/ Superintending Engineer may in his discretion, without prejudice to any other right or remedy available in law, cancel the contract. The contractor shall also be liable for any pecuniary liability arising on account of any violation by him of the provisions of the said Act.

## CONDITIONS OF CONTRACT

### Definitions

1. The **Contract** means the documents forming the tender and acceptance thereof and the formal agreement executed between the Central Warehousing Corporation and the Contractor, together with the documents referred to therein including these conditions, the specifications, designs, drawings and instructions issued from time to time by the Engineer-in- Charge and all these documents taken together, shall be deemed to form one contract and shall be complementary to one another.

2. In the contract, the following expressions shall, unless the context otherwise requires, have the meanings, hereby respectively assigned to them:-

(i) The expression **Works** or **Work** shall, unless there be something either in the subject or context repugnant to such construction, be construed and taken to mean the works by or by virtue of the contract contracted to be executed whether temporary or permanent, and whether original, altered, substituted or additional.

(ii) The **Site** shall mean the land/or other places on, into or through which work is to be executed under the contract or any adjacent land, path or street through which work is to be executed under the contract or any adjacent land, path or street which may be allotted or used for the purpose of carrying out the contract.

(iii) The **Contractor** shall mean the individual, firm or company, whether incorporated or not, undertaking the works and shall include the legal personal representative of such individual or the persons composing such firm or company, or the successors of such firm or company and the permitted assignees of such individual, firm or company.

(iv) The **Corporation/ Corpn./ Department** means the Central Warehousing Corporation.(CWC)

(v) The **Engineer-in-Charge** means the Chief Engineer/ Superintending Engineer who shall monitor and be in charge of the work and who shall sign the contract on behalf of the Central Warehousing Corporation.

(vi) **Accepting Authority** shall mean the authority mentioned in Schedule 'F'.

(vii) **Excepted Risk** are risks due to riots (other than those on account of contractor's employees), war (whether declared or not) invasion, act of foreign enemies, hostilities, civil war, rebellion revolution, insurrection, military or usurped power, any acts of Government, damages from aircraft, acts of God, such as earthquake,

lightening and unprecedented floods, and other causes over which the contractor has no control and accepted as such by the Accepting Authority or causes solely due to use or occupation by Corporation of the part of the works in respect of which a certificate of completion has been issued or a cause solely due to faulty design of works.

(viii) **Market Rate** shall be the rate as decided by the Engineer-in-Charge on the basis of the cost of materials and labour at the site where the work is to be executed plus the percentage mentioned in Schedule 'F' to cover, all overheads and profits.

**Provided that no extra overheads and profits shall be payable on the part(s) of work assigned to other agency(s) by the contractor as per terms of contract.**

(ix) **Schedule(s)** referred to in these conditions shall mean the relevant schedule(s) annexed to the tender papers or the standard Schedule of Rates applicable mentioned in Schedule 'F' hereunder, with the amendments thereto issued up to the date of receipt of the tender.

(x) **Department** means CWC or any department of Government of India which invites tenders on behalf of Corporation as specified in schedule 'F'.

(xi) **District Specifications** means the specifications followed by the State Government in the area where the work is to be executed.

(xii) **Tendered value** means the value of the entire work as stipulated in the letter of award.

(xiii) **Date of commencement of work:** The date of commencement of work shall be the date of start as specified in schedule 'F' or the first date of handing over of the site, whichever is later, in accordance with the phasing if any, as indicated in the tender document.

**(xiv) GST shall mean Goods and Service Tax- Central, State and Inter State.**

**Scope and Performance**

3. Where the context so requires, words imparting the singular only also include the plural and vice versa. Any reference to masculine gender shall whenever required include feminine gender and vice versa.

4. Headings and Marginal notes to these General Conditions of Contract shall not be deemed to form part thereof or be taken into consideration in the interpretation or construction thereof or of the contract.

5. The contractor shall be furnished, free of cost one certified copy of the contract documents except standard specifications, Schedule of Rates and such other printed

and published documents, together with all drawings as may be forming part of the tender papers. None of these documents shall be used for any purpose other than that of this contract.

**Works to be carried out** 6. The work to be carried out under the Contract shall, except as otherwise provided in these conditions, include all labour, materials, tools, plants, equipment and transport which may be required in preparation of and for and in the full and entire execution and completion of the works. The descriptions given in the Schedule of Quantities (Schedule- A) shall, unless otherwise stated, be held to include wastage on materials, carriage and cartage, carrying and return of empties, hoisting, setting, fitting and fixing in position and all other labours necessary in and for the full and entire execution and completion of the work as aforesaid in accordance with good practice and recognized principles.

**Sufficiency of Tender** 7. The Contractor shall be deemed to have satisfied himself before tendering as to the correctness and sufficiency of his tender for the works and of the rates and prices quoted in the Schedule of Quantities, which rates and prices shall, except as otherwise provided, cover all his obligations under the Contract and all matters and things necessary for the proper completion and maintenance of the works.

**Discrepancies and Adjustment of Errors** 8. The several documents forming the Contract are to be taken as mutually explanatory of one another, detailed drawings being followed in preference to small scale drawing and figured dimensions in preference to scale and Special Conditions in preference to General Conditions.

8.1 In the case of discrepancy between the schedule of Quantities, the Specifications and/ or the Drawings, the following order of preference shall be observed:-

- i) Bill of Quantities (BOQ)
- ii) Technical specifications
- iii) Drawings
- iv) Special Conditions of Contract
- v) General Conditions of Contract
- vi) Instructions to Tenderers

8.2 If there are varying or conflicting provisions made in any one document forming part of the contract, the Accepting Authority shall be the deciding authority with regard to the intention of the document and his decision shall be final and binding on the contractor.

8.3 Any error in description, quantity or rate in Schedule of Quantities or any omission there from shall not vitiate the Contract or release the Contractor from the execution of the whole or any part of the works comprised therein according to drawings and specifications or from any of his obligations under the contract.

**Signing of Contract**

9. The successful tenderer/contractor, on acceptance of his tender by the Accepting Authority, shall, within 15 days from the stipulated date of start of the work, sign the contract consisting of:-

- (i) The Notice Inviting Tender, all the documents including drawings, if any, forming the tender as issued at the time of invitation of tender and acceptance thereof together with any correspondence leading thereto.
- (ii) Standard C.P.W.D. Form as mentioned in Schedule 'F' consisting of:
  - a) Various standard clauses with corrections up to the date stipulated in Schedule 'F' along with annexures thereto.
  - b) Safety Code.
  - c) Model Rules for the protection of health, sanitary arrangements for workers employed by CWC or its contractors.
  - d) CPWD Contractor's Labour Regulations shall *Mutatis Mutandis* apply to the work of CWC.
  - e) List of Acts and omissions for which fines can be imposed.
- (iii) No payment for the work done will be made unless contract is signed by the contractor.

**CLAUSES OF CONTRACT**

**CLAUSE 1**

**Performance Guarantee**

The contractor shall submit an irrevocable Performance Guarantee of 5% (Five percent) of the tendered amount in addition to other deposits mentioned elsewhere in the contract for his proper performance of the contract agreement, (not withstanding and/or without prejudice to any other provisions in the contract) within period specified in Schedule 'F' from the date of issue of letter of acceptance. This period can be further extended by the Engineer-in-Charge up to a maximum period as specified in schedule 'F' on written request of the contractor stating the reason for delays in procuring the Performance Guarantee, to the satisfaction of the Engineer-in-Charge. This guarantee shall be in the form of Cash (in case guarantee amount is less than Rs. 10,000/-) or Deposit at Call receipt of any scheduled bank/Banker's Cheque of any scheduled bank/Demand Draft of any scheduled bank/Pay Order of any scheduled bank (in case guarantee amount is less than Rs. 1,00,000/-) or Government Securities or Fixed Deposit Receipts or Guarantee Bonds of any Scheduled Bank or the State Bank of India in accordance with the form annexed hereto. In case a fixed deposit receipt of any Bank is furnished by the contractor to the Corporation as part of the performance guarantee and the Bank is



unable to make payment against the said fixed deposit receipt, the loss caused thereby shall fall on the contractor and the contractor shall forthwith on demand furnish additional security to the Corporation to make good the deficit.

ii) The Performance Guarantee shall be initially valid up to the stipulated date of completion plus 60 days beyond that. In case the time for completion of work gets enlarged, the contractor shall get the validity of Performance Guarantee extended to cover such enlarged time for completion of work. After recording of the completion certificate for the work by the competent authority, the performance guarantee shall be returned to the contractor, without any interest. However, in case of contracts involving maintenance of building and services/any other work after construction of same building and services/other work, then 50% of Performance Guarantee shall be retained as Security Deposit. The same shall be returned year wise proportionately.

(iii) The Engineer-in-Charge shall not make a claim under the performance guarantee except for amounts to which the Corporation is entitled under the contract (not withstanding and/or without prejudice to any other provisions in the contract agreement) in the event of:

(a) Failure by the contractor to extend the validity of the Performance Guarantee as described herein above, in which event the Engineer-in-Charge may claim the full amount of the Performance Guarantee.

(b) Failure by the contractor to pay Corporation any amount due, either as agreed by the contractor or determined under any of the Clauses/Conditions of the agreement, within 30 days of the service of notice to this effect by Engineer-in-Charge.

(iv) In the event of the contract being determined or rescinded under provision of any of the Clause/Condition of the agreement, the performance guarantee shall stand forfeited in full and shall be absolutely at the disposal of the Corporation.

**(v) On substantial Completion of any work which has been completed to such an extent that the intended purpose of the work is met and ready to use, then a provisional Completion certificate shall be recorded by the Engineer-in-Charge. The provisional certificate shall have appended with a list of outstanding balance item of work that need to be completed in accordance with the provisions of the contract.**

**This provisional completion certificate shall be recorded by the concerned Engineer- in-charge with the approval of Project Manager / Chief Project Manager /Superintending Engineer. After :recording of the provisional**

**Completion Certificate for the work by the competent authority, the 80 % of performance guarantee shall be returned to the contractor, without any interest.**

**However in case of contracts involving Maintenance of building and services / any other work after construction of same building and services/ other work, then 40% of performance guarantee shall be returned to the contractor, without any interest after recording the provisional Completion certificate.**

#### **CLAUSE 1 A**

**Recovery of  
Security  
Deposit**

The person/persons whose tender(s) may be accepted (hereinafter called the contractor) shall permit Corporation at the time of making any payment to him for work done under the contract to deduct a sum at the rate of 2.5% of the gross amount of each running and final bill till the sum deducted will amount to security deposit of 2.5% of the tendered value of the work. Such deductions will be made and held by Corporation by way of Security Deposit unless he/they has/have deposited the amount of Security at the rate mentioned above in cash or in the form of Government Securities or fixed deposit receipts. In case a fixed deposit receipt of any Bank is furnished by the contractor to the Corporation as part of the security deposit and the Bank is unable to make payment against the said fixed deposit receipt, the loss caused thereby shall fall on the contractor and the contractor shall forthwith on demand furnish additional security to the Corporation to make good the deficit. All compensations or the other sums of money payable by the contractor under the terms of this contract may be deducted from, or paid by the sale of a sufficient part of his security deposit or from the interest arising therefrom, or from any sums which may be due to or may become due to the contractor by Corporation on any account whatsoever and in the event of his Security Deposit being reduced by reason of any such deductions or sale as aforesaid, the contractor shall within 10 days make good in cash or fixed deposit receipt tendered by the State Bank of India or by Scheduled Banks or Government Securities (if deposited for more than 12 months) endorsed in favour of the Engineer-in-Charge, any sum or sums which may have been deducted from, or raised by sale of his security deposit or any part thereof. The security deposit shall be collected from the running bills and the final bill of the contractor at the rates mentioned above.

The security deposit as deducted above can be released against bank guarantee issued by a scheduled bank, on its accumulations to a minimum of Rs. 5 lacs subject to the condition that amount of such bank guarantee, except last one, shall not be less than Rs. 5 lacs. Provided further that the validity of bank guarantee including the one given against the earnest money shall be in

conformity with provisions contained in clause 17 which shall be extended from time to time depending upon extension of contract granted under provisions of clause 2 and clause 5.

In case of contracts involving maintenance of building and services/any other work after construction of same building and services/other work, then 50% of Performance Guarantee shall be retained as Security Deposit. The same shall be returned year wise proportionately.

**Note-1:** Government papers tendered as security will be taken at 5% (five per cent) below its market price or at its face value, whichever is less. The market price of Government paper would be ascertained by the Chief Engineer/ Superintending Engineer at the time of collection of interest and the amount of interest to the extent of deficiency in value of the Government paper will be withheld if necessary.

**Note-2:** Government Securities will include all forms of Securities mentioned in Rule No. 274 of the G.F. Rules except fidelity bond. This will be subject to the observance of the condition mentioned under the rule against each form of security.

**Note-3:** Note 1 & 2 above shall be applicable for both clause 1 and 1A

## CLAUSE 2

### Compensation for delay

If the contractor fails to maintain the required progress in terms of clause 5 or to complete the work and clear the site on or before the contract or justified extended date of completion as per clause 5 (excluding any extension under Clause 5.5) as well as any extension granted under clauses 12 and 15, he shall, without prejudice to any other right or remedy available under the law to the CWC on account of such breach, pay as compensation the amount calculated at the rates stipulated below as the authority specified in schedule 'F' may decide on the amount of Tendered Value of the work for every completed day/month (as determined) that the progress remains below that specified in Clause 5 or that the work remains incomplete.

(i) Compensation for delay of work @ 1% per month of day to be computed on per day basis.

Provided always that the total amount of compensation for delay to be paid under this condition shall not exceed 10 % of the Tendered Value of work or of the Tendered Value of the Sectional part of work as mentioned in Schedule 'F' for which a separate period of completion is originally given.

In case no compensation has been decided by the authority in Schedule 'F' during the progress of work, this shall be no waiver of right to levy compensation by the said authority if the work remains incomplete on final justified extended date of completion. If the Engineer in Charge decides to give

further extension of time allowing performance of work beyond the justified extended date, the contractor shall be liable to pay compensation for such extended period. If any variation in amount of contract takes place during such extended period beyond justified extended date and the contractor becomes entitled to additional time under clause 12, the net period for such variation shall be accounted for while deciding the period for levy of compensation. However, during such further extended period beyond the justified extended period, if any delay occurs by events under sub clause 5.2, the contractor shall be liable to pay compensation for such delay.

Provided that compensation during the progress of work before the justified extended date of completion for delay under this clause shall be for non-achievement of sectional completion or part handing over of work on stipulated/justified extended date for such part work or if delay affects any other works/services. This is without prejudice to right of action by the Engineer in Charge under clause 3 for delay in performance and claim of compensation under that clause.

In case action under clause 2 has not been finalized and the work has been determined under clause 3, the right of action under this clause shall remain post determination of contract but levy of compensation shall be for days the progress is behind the schedule on date of determination, as assessed by the authority in Schedule F, after due consideration of justified extension. The compensation for delay, if not decided before the determination of contract, shall be decided after of determination of contract.

The amount of compensation may be adjusted or set-off against any sum payable to the Contractor under this or any other contract with the Corporation. In case, the contractor does not achieve a particular milestone mentioned in schedule F, or the re-scheduled milestone(s) in terms of Clause 5.4, the amount shown against that milestone shall be withheld, to be adjusted against the compensation levied as above. With-holding of this amount on failure to achieve a milestone, shall be automatic without any notice to the contractor. However, if the contractor catches up with the progress of work on the subsequent milestone(s), the withheld amount shall be released. In case the contractor fails to make up for the delay in subsequent milestone(s), amount mentioned against each milestone missed subsequently also shall be withheld. However, no interest, whatsoever, shall be payable on such withheld amount.

#### **CLAUSE 2A - DELETED**

**Incentive for  
Early**

~~In case, the contractor completes the work ahead of stipulated date of completion or justified extended date of completion as determined under~~

**Completion** ~~clauses 5.3, 12 & 15, a bonus @ 1% (one per cent) of the tendered value per month computed on per day basis, shall be payable to the contractor, subject to a maximum limit of 5% (five per cent) of the tendered value. Provided that justified time for extra work shall be calculated on pro-rata basis as cost of extra work X stipulated period /tendered value. The amount of bonus, if payable, shall be paid along with final bill after completion of work. Provided always that provision of the Clause 2A shall be applicable only when so provided in 'Schedule F'.~~

### **CLAUSE 3**

**When Contract can be Determined** Subject to other provisions contained in this clause, the Engineer-in-Charge may, without prejudice to his any other rights or remedy against the contractor in respect of any delay, inferior workmanship, any claims for damages and/or any other provisions of this contract or otherwise, and whether the date of completion has or has not elapsed, by notice in writing absolutely determine the contract in any of the following cases:

(i) If the contractor having been given by the Engineer-in-Charge a notice in writing to rectify, reconstruct or replace any defective work or that the work is being performed in an inefficient or otherwise improper or unworkman like manner shall omit to comply with the requirement of such notice for a period of seven days thereafter.

(ii) If the contractor has, without reasonable cause, suspended the progress of the work or has failed to proceed with the work with due diligence and continues to do so after a notice in writing of seven days from the Engineer-in-Charge.

(iii) If the contractor fails to complete the work or section of work with individual date of completion on or before the stipulated or justified extended date, on or before such date of completion; and the Engineer in Charge without any prejudice to any other right or remedy under any other provision in the contract has given further reasonable time in a notice given in writing in that behalf as either mutually agreed or in absence of such mutual agreement by his own assessment making such time essence of contract and in the opinion of Engineer-in-Charge the contractor will be unable to complete the same or does not complete the same within the period specified.

(iv) If the contractor persistently neglects to carry out his obligations under the contract and/ or commits default in complying with any of the terms and conditions of the contract and does not remedy it or take effective steps to

remedy it within 7 days after a notice in writing is given to him in that behalf by the Engineer-in-Charge.

(v) If the contractor shall offer or give or agree to give to any person in Corporation service or to any other person on his behalf any gift or consideration of any kind as an inducement or reward for doing or forbearing to do or for having done or forborne to do any act in relation to the obtaining or execution of this or any other contract for Corporation.

(vi) If the contractor shall enter into a contract with Corporation in connection with which commission has been paid or agreed to be paid by him or to his knowledge, unless the particulars of any such commission and the terms of payment thereof have been previously disclosed in writing to the Engineer-in-Charge.

(vii) If the contractor had secured the contract with Corporation as a result of wrong tendering or other non-bonafide methods of competitive tendering or commits breach of Integrity Agreement.

(viii) If the contractor being an individual, or if a firm, any partner thereof shall at any time be adjudged insolvent or have a receiving order or order for administration of his estate made against him or shall take any proceedings for liquidation or composition (other than a voluntary liquidation for the purpose of amalgamation or reconstruction) under any Insolvency Act for the time being in force or make any conveyance or assignment of his effects or composition or arrangement for the benefit of his creditors or purport so to do, or if any application be made under any Insolvency Act for the time being in force for the sequestration of his estate or if a trust deed be executed by him for benefit of his creditors.

(ix) If the contractor being a company shall pass a resolution or the court shall make an order that the company shall be wound up or if a receiver or a manager on behalf of a creditor shall be appointed or if circumstances shall arise which entitle the court or the creditor to appoint a receiver or a manager or which entitle the court to make a winding up order.

(x) If the contractor shall suffer an execution being levied on his goods and allow it to be continued for a period of 21 days.

(xi) If the contractor assigns (excluding part(s) of work assigned to other agency(s) by the contractor as per terms of contract),transfers, sublets

(engagement of labour on a piece-work basis or of labour with materials not to be incorporated in the work, shall not be deemed to be subletting) or otherwise parts with or attempts to assign, transfer, sublet or otherwise parts with the entire works or any portion thereof without the prior written approval of the Engineer -in-Charge. When the contractor has made himself liable for action under any of the cases aforesaid, the Engineer-in-Charge on behalf of the Corporation shall have powers:

When the contractor has made himself liable for action under any of the cases aforesaid, the Engineer-in-Charge on behalf of the Corporation shall have powers:

(a) To determine the contract as aforesaid so far as performance of work by the Contractor is concerned (of which determination notice in writing to the contractor under the hand of the Engineer-in-Charge shall be conclusive evidence). Upon such determination, the Earnest Money Deposit, Security Deposit already recovered and Performance Guarantee under the contract shall be liable to be forfeited and shall be absolutely at the disposal of the Central Warehousing Corporation

(b) After giving notice to the contractor to measure up the work of the contractor and to take such whole, or the balance or part thereof, as shall be un-executed out of his hands and to give it to another contractor to complete the work. The contractor, whose contract is determined as above, shall not be allowed to participate in the tendering process for the balance work. In the event of above courses being adopted by the Engineer-in-Charge, the contractor shall have no claim to compensation for any loss sustained by him by reasons of his having purchased or procured any materials or entered into any engagements or made any advances on account or with a view to the execution of the work or the performance of the contract. And in case action is taken under any of the provision aforesaid, the contractor shall not be entitled to recover or be paid any sum for any work thereof or actually performed under this contract unless and until the Engineer-in-Charge has certified in writing the performance of such work and the value payable in respect thereof and he shall only be entitled to be paid the value so certified.

### **CLAUSE 3A**

In case, the work cannot be started due to reasons not within the control of the contractor within 1/8th of the stipulated time for completion of work or one month whichever is higher, either party may close the contract by giving notice to the other party stating the reasons. In such eventuality, the Performance Guarantee of the contractor shall be refunded within following time limits :

- (i) If the Tendered value of work is up to Rs. 45 lac : 15 days.
- (ii) If the Tendered value of work is more than Rs. 45 lac  
and up to Rs. 2.5 Crore : 21 days.
- (iii) If the Tendered value of work exceeds Rs. 2.5 Crore : 30 days.

Neither party shall claim any compensation for such eventuality.

This clause is not applicable for any breach of the contract by either party.

#### CLAUSE 4

**Contractor liable topay Compensation even if action not taken under Clause 3** In any case in which any of the powers conferred upon the Engineer-in-Charge by Clause-3 thereof, shall have become exercisable and the same are not exercised, the non-exercise thereof shall not constitute a waiver of any of the conditions hereof and such powers shall notwithstanding be exercisable in the event of any future case of default by the contractor and the liability of the contractor for compensation shall remain unaffected. In the event of the Engineer-in-Charge putting in force all or any of the powers vested in him under the preceding clause he may, if he so desires after giving a notice in writing to the contractor, take possession of (or at the sole discretion of the Engineer-in-Charge which shall be final and binding on the contractor) use as on hire (the amount of the hire money being also in the final determination of the Engineer-in-Charge) all or any tools, plant, materials and stores, in or upon the works, or the site thereof belonging to the contractor, or procured by the contractor and intended to be used for the execution of the work/or any part thereof, paying or allowing for the same in account at the contract rates, or, in the case of these not being applicable, at current market rates to be certified by the Engineer-in-Charge, whose certificate thereof shall be final, and binding on the contractor, clerk of the works, foreman or other authorized agent to remove such tools, plant, materials, or stores from the premises (within a time to be specified in such notice) in the event of the contractor failing to comply with any such requisition, the Engineer-in-Charge may remove them at the contractor's expense or sell them by auction or private sale on account of the contractor and his risk in all respects and the certificate of the Engineer-in-Charge as to the expenses of any such removal and the amount of the proceeds and expenses of any such sale shall be final and conclusive against the contractor.



## CLAUSE 5

### Time and Extension for Delay

The time allowed for execution of the Works as specified in the Schedule 'F' or the extended time in accordance with these conditions shall be the essence of the Contract. The execution of the work shall commence from such time period as mentioned in schedule 'F' or from the date of handing over of the site, notified by the Engineer-in-Charge, whichever is later. However, the handing over of site by the Engineer in Charge, in full or in part (if so provided in contract), shall be completed within two months from issue of acceptance letter. If the Contractor commits default in commencing the execution of the work as aforesaid, the performance guarantee shall be forfeited by the Engineer in Charge and shall be absolutely at the disposal of the Corporation without prejudice to any other right or remedy available in law.

5.1 As soon as possible but within twenty one days of award of work and in consideration of

- a) Schedule of handing over of site as specified in the Schedule 'F'
- b) Schedule of issue of designs as specified in the Schedule 'F'

(i) the Contractor shall submit a Time and Progress Chart for each mile stone. The Engineer-in-Charge may within 30 days thereafter, if required modify, and communicate the program approved to the contractor failing which the program submitted by the contractor shall be deemed to be approved by the Engineer-in- Charge. The work programme shall include all details of balance drawings and decisions required to complete the contract with specific dates by which these details are required by contractor without causing any delay in execution of the work. The Chart shall be prepared in direct relation to the time stated in the Contract documents for completion of items of the works. It shall indicate the forecast of the dates of commencement and completion of various trades of sections of the work and may be amended as necessary by agreement between the Engineer-in-Charge and the Contractor within the limitations of time imposed in the Contract documents, and further to ensure good progress during the execution of the work, the contractor shall in all cases in which the time allowed for any work, exceeds one month (save for special jobs for which a separate programme has been agreed upon) complete the work as per mile stones given in Schedule 'F'.

(ii) In case of non-submission of construction programme by the contractor the program approved by the Engineer-in-Charge shall be deemed to be final.

(iii) The approval by the Engineer-in-Charge of such programme shall not relieve the contractor of any of the obligations under the contract.

(iv) The contractor shall submit the Time and Progress Chart and progress

report using the mutually agreed software or in other format decided by Engineer-in-Charge for the work done during previous month to the Engineer-in-charge on or before 5th day of each month failing which a recovery Rs. 2500/- (for works costing up to Rs. 20 Crores) / Rs. 5000/- (for works costing more than Rs. 20 Crores) shall be made on per week or part basis in case of delay in submission of the monthly progress report.

**5.2** If the work(s) be delayed by:-

- (i) force of majeure, or
  - (ii) abnormally bad weather, or
  - (iii) serious loss or damage by fire, or
  - (iv) civil commotion, local commotion of workmen, strike or lockout, affecting any of the trades employed on the work, or
  - (v) delay on the part of other contractors or tradesmen engaged by Engineer-in-Charge in executing work not forming part of the Contract, or
  - (vi) non-availability of stores, which are the responsibility of Corporation to supply or
  - (vii) non-availability or break down of tools and Plant to be supplied or supplied by Corporation
- or
- (viii) any other cause like above which, in the reasoned opinion of the Engineer-in-Charge is beyond the Contractor's control.

then upon the happening of any such event causing delay, the Contractor shall immediately give notice thereof in writing to the Engineer-in-charge for entry in the hindrance register (physical or web-based as prescribed in Schedule 'F') but shall nevertheless use constantly his best endeavours to prevent or make good the delay and shall do all that may be reasonably required to the satisfaction of the Engineer-in-Charge to proceed with the works. The contractor shall have no claim of damages for extension of time granted or rescheduling of milestone/s for events listed in sub clause 5.2.

**5.3** In case the work is hindered by any reasons, in the opinion of the contractor, by the Department or for someone for whose action the Department is responsible, the contractor may immediately give notice thereof in writing to the Engineer-in-Charge in the same manner as prescribed under sub Clause 5.2 seeking extension of time or rescheduling of milestone/s. The authority as indicated in Schedule 'F' shall, if justified, give a fair and reasonable extension of time and reschedule the mile stones for completion of work after due consideration of the same within 30 days of receipt of such request. In event of non-application by the contractor for

extension of time Engineer-in-Charge after affording opportunity to the contractor may give, supported with a programme, a fair and reasonable extension within a reasonable period of occurrence of the event.

Such extension of time or rescheduling of milestone/s shall be without prejudice to any other right or remedy of the parties in contract or in law; provided further that for concurrent delays under this sub clause and sub clause 5.2 to the extent the delay is covered under sub clause 5.2 the contractor shall be entitled to only extension of time and no damages.

**5.4** Request for rescheduling of Mile stones or extension of time, to be eligible for consideration, shall be made by the Contractor in writing within fourteen days of the happening of the event causing delay on the prescribed forms i.e. Form of application by the contractor for seeking rescheduling of milestones (Appendix-XVI) or Form of application by the contractor for seeking extension of time (Appendix –XVII) respectively to the authority as indicated in Schedule 'F'. The Contractor shall indicate in such a request the period by which rescheduling of milestone/s or extension of time is desired.

With every request for rescheduling of milestones, or if at any time the actual progress of work falls behind the approved programme by more than 10% of the stipulated period of completion of contract, the contractor shall produce a revised programme which shall include all details of pending drawings and decisions required to complete the contract and also the target dates by which these details should be available without causing any delay in execution of the work. A recovery as specified in Schedule 'F' shall be made on per day basis in case of delay in submission of the revised programme.

**5.4.1** In any such case the authority as indicated in Schedule 'F' may give a fair and reasonable extension of time for completion of work or reschedule the mile stones. Such extension or rescheduling of the milestones shall be communicated to the Contractor by the authority as indicated in Schedule 'F' in writing, within 30 days of the date of receipt of such request from the Contractor in prescribed form. In event of non-application by the contractor for extension of time E-in-C after affording opportunity to the contractor, may give, supported with a programme (as specified under 5.4 above), a fair and reasonable extension within a reasonable period of occurrence of the event.

**5.5** In case the work is delayed by any reasons, in the opinion of the Engineer-in-Charge, by the contractor for reasons beyond the events mentioned in clause 5.2 or clause 5.3 or clause 5.4 and beyond the justified extended date; without prejudice to right to take action under Clause 3, the Engineer-in-Charge may grant extension of time required for completion of

work without rescheduling of milestones. The contractor shall be liable for levy of compensation for delay for such extension of time.

#### **CLAUSE 6**

**Measurements  
of  
Work Done**

Engineer-in-Charge shall, except as otherwise provided, ascertain and determine by measurement, the value in accordance with the contract of work done.

All measurement of all items having financial value shall be entered in Measurement Book and/or level field book so that a complete record is obtained of all works performed under the contract.

All measurements and levels shall be taken jointly by the Engineer-in-Charge or his authorized representative and by the contractor or his authorized representative from time to time during the progress of the work and such measurements shall be signed and dated by the Engineer-in-Charge and the contractor or their representatives in token of their acceptance. If the contractor objects to any of the measurements recorded, a note shall be made to that effect with reason and signed by both the parties.

If for any reason the contractor or his authorized representative is not available and the work of recording measurements is suspended by the Engineer-in-Charge or his representative, the Engineer-in-Charge and the Department shall not entertain any claim from contractor for any loss or damages on this account. If the contractor or his authorized representative does not remain present at the time of such measurements after the contractor or his authorized representative has been given a notice in writing three (3) days in advance or fails to countersign or to record objection within a week from the date of the measurement, then such measurements recorded in his absence by the Engineer-in-Charge or his representative shall be deemed to be accepted by the Contractor.

The contractor shall, without extra charge, provide all assistance with every appliance, labour and other things necessary for measurements and recording levels.

Except where any general or detailed description of the work expressly shows to the contrary, measurements shall be taken in accordance with the procedure set forth in the specifications notwithstanding any provision in the relevant Standard Method of measurement or any general or local custom. In

the case of items which are not covered by specifications, measurements shall be taken in accordance with the relevant standard method of measurement issued by the Bureau of Indian Standards and if for any item no such standard is available, then a mutually agreed method shall be followed.

The contractor shall give, not less than seven days' notice to the Engineer-in-Charge or his authorized representative in charge of the work, before covering up or otherwise placing beyond the reach of measurement any work in order that the same may be measured and correct dimensions thereof be taken before the same is covered up or placed beyond the reach of measurement and shall not cover up and place beyond reach of measurement any work without consent in writing of the Engineer-in-Charge or his authorized representative in charge of the work who shall within the aforesaid period of seven days inspect the work, and if any work shall be covered up or placed beyond the reach of measurements without such notice having been given or the Engineer-in-Charge's consent being obtained in writing, the same shall be uncovered at the Contractor's expense, or in default thereof no payment or allowance shall be made for such work or the materials with which the same was executed.

Engineer-in-Charge or his authorized representative may cause either themselves or through another officer of the department to check the measurements recorded jointly or otherwise as aforesaid and all provisions stipulated herein above shall be applicable to such checking of measurements or levels.

It is also a term of this contract that recording of measurements of any item of work in the measurement book and/or its payment in the interim, on account or final bill shall not be considered as conclusive evidence as to the sufficiency of any work or material to which it relates nor shall it relieve the contractor from liabilities from any over measurement or defects noticed till completion of the defects liability period.

#### **CLAUSE 6A**

**Computerized  
Measurement  
Book**

Engineer-in-Charge shall, except as otherwise provided, ascertain and determine by measurement the value of work done in accordance with the contract.

All measurements of all items having financial value shall be entered by the contractor and compiled in the shape of the Computerized Measurement Book having pages of A-4 size as per the format of the department so that a

complete record is obtained of all the items of works performed under the contract.

All such measurements and levels recorded by the contractor or his authorized representative from time to time, during the progress of the work, shall be got checked by the contractor from the Engineer-in-Charge or his authorized representative as per interval or program fixed in consultation with Engineer-in-Charge or his authorized representative. After the necessary corrections made by the Engineer-in-Charge, the measurement sheets shall be returned to the contractor for incorporating the corrections and for resubmission to the Engineer-in-Charge for the dated signatures by the Engineer-in-Charge and the contractor or their representatives in token of their acceptance.

Whenever bill is due for payment, the contractor would initially submit draft computerized measurement sheets and these measurements would be got checked/test checked from the Engineer-in-Charge and/or his authorized representative. The contractor will, thereafter, incorporate such changes as may be done during these checks/test checks in his draft computerized measurements, and submit to the department a computerized measurement book, duly bound, and with its pages machine numbered. The Engineer-in-Charge and/or his authorized representative would thereafter check this MB, and record the necessary certificates for their checks/test checks.

The final, fair, computerized measurement book given by the contractor, duly bound, with its pages machine numbered, should be 100% correct, and no cutting or over-writing in the measurements would thereafter be allowed. If at all any error is noticed, the contractor shall have to submit a fresh computerized MB with its pages duly machine numbered and bound, after getting the earlier MB cancelled by the department. Thereafter, the MB shall be taken in the Divisional Office records, and allotted a number as per the Register of Computerised MBs. This should be done before the corresponding bill is submitted to the Office for payment. The contractor shall submit two spare copies of such computerized MB's for the purpose of reference and record by the various officers of the department.

The contractor shall also submit to the department separately his computerized Abstract of Cost and the bill based on these measurements, duly bound, and its pages machine numbered along with two spare copies of the "bill. Thereafter, this bill will be processed by the Office and allotted a number as per the computerized record in the same way as done for the measurement book meant for measurements.

The contractor shall, without extra charge, provide all assistance with every appliance, labour and other things necessary for checking of measurements/levels by the Engineer-in- Charge or his representative.

Except where any general or detailed description of the work expressly shows to the contrary, measurements shall be taken in accordance with the procedure set forth in the specifications notwithstanding any provision in the relevant Standard Method of measurement or any general or local custom. In the case of items which are not covered by specifications, measurements shall be taken in accordance with the relevant standard method of measurement issued by the Bureau of Indian Standards and if for any item no such standard is available then a mutually agreed method shall be followed.

The contractor shall give not less than seven days' notice to the Engineer-in-Charge or his authorized representative in charge of the work before covering up or otherwise placing beyond the reach of checking and/or test checking the measurement of any work in order that the same may be checked and/or test checked and correct dimensions thereof be taken before the same is covered up or placed beyond the reach of checking and/or test checking measurement and shall not cover up and place beyond reach of measurement any work it out consent in writing of the Engineer-in-Charge or his authorized representative in charge of the work who shall within the aforesaid period of seven days inspect the work, and if any work shall be covered up or placed beyond the reach of checking and/or test checking measurements without such notice having been given or the Engineer-in-Charge's consent being obtained in writing the same shall be uncovered at the Contractor's expense, or in default thereof no payment or allowance shall be made for such work or the materials with which the same was executed.

Engineer-in-Charge or his authorized representative may cause either themselves or through another officer of the department to check the measurements recorded by contractor and all provisions stipulated herein above shall be applicable to such checking of measurements or levels.

It is also a term of this contract that checking and/or test checking the measurements of any item of work in the measurement book and/or its payment in the interim, on account of final bill shall not be considered as conclusive evidence as to the sufficiency of any work or material to which it relates nor shall it relieve the contractor from liabilities from any over measurement or defects noticed till completion of the defects liability period.

## CLAUSE 7

**Payment on Intermediate Certificate to be Regarded as Advances** No payment shall be made for work, estimated to cost Rs. **One lac** or less till after the whole of the work shall have been completed and certificate of completion given. For works estimated to cost over Rs. **One lac**, the interim or running account bills shall be submitted by the contractor for the work executed on the basis of such recorded measurements on the format of the Department in triplicate on or before the date of every month fixed for the same by the Engineer-in-Charge. The contractor shall not be entitled to be paid any such interim payment if the gross work done together with net payment/ adjustment of advances for material collected, if any, since the last such payment is less than the amount specified in Schedule 'F', in which case the interim bill shall be prepared on the appointed date of the month after the requisite progress is achieved. Engineer-in-Charge shall arrange to have the bill verified by taking or causing to be taken, where necessary, the requisite measurements of the work. In the event of the failure of the contractor to submit the bills, no claims whatsoever due to delays on payment including that of interest shall be payable to the contractor. Payment on account of amount admissible shall be made by the Engineer-in-Charge certifying the sum to which the contractor is considered entitled by way of interim payment at such rates as decided by the Engineer-in-Charge. The amount admissible shall be paid by 10th working day after the day of presentation of the bill by the Contractor to the Engineer-in-Charge or his Asset. Engineer together with the account of the material issued by the department, or dismantled materials, if any. In the case of works outside the headquarters of the Engineer- in-Charge, the period of ten working days will be extended to fifteen working days.

All such interim payments shall be regarded as payment by way of advances against final payment only and shall not preclude the requiring of bad, unsound and imperfect or unskilled work to be rejected, removed, taken away and reconstructed or re-erected. Any certificate given by the Engineer-in-Charge relating to the work done or materials delivered forming part of such payment, may be modified or corrected by any subsequent such certificate(s) or by the final certificate and shall not by itself be conclusive evidence that any work or materials to which it relates is/are in accordance with the contract and specifications. Any such interim payment, or any part thereof shall not in any respect conclude, determine or affect in anyway powers of the Engineer-in-Charge under the contract or any of such payments be treated as final settlement and adjustment of accounts or in any way vary or affect the contract.



Pending consideration of extension of date of completion, interim payments shall continue to be made as herein provided without prejudice to the right of the department to take action under the terms of this contract for delay in the completion of work, if the extension of date of completion is not granted by the competent authority.

The Engineer-in-Charge in his sole discretion on the basis of a certificate from the Assistant Engineer/ Executive Engineer to the effect that the work has been completed up to the level in question make interim advance payments without detailed measurements for work done (other than foundations, items to be covered under finishing items) up to lintel level (including sunshade etc.) and slab level, for each floor working out at 75% of the assessed value. The advance payments so allowed shall be adjusted in the subsequent interim bill to be submitted by the contractor within 10 days of the interim payment. In case of delay in submission of bill by the contractor a simple interest @ 10% per annum shall be paid to the Corporation from the date of expiry of prescribed time limit which will be compounded on yearly basis.

**Payment in  
Composite  
Contracts**

In case of composite tenders, running payment for the major component shall be made by EE of major discipline to the main contractor. Running payment for minor component shall be made by the Engineer-in-Charge of the discipline of minor component directly to the main contractor.

In case main contractor fails to make the payment to the contractor associated by him within 15 days of receipt of each running account payment, then on the written complaint of contractor associated for such minor component, Engineer in charge of minor component shall serve the show cause to the main contractor and if reply of main contractor either not received or found unsatisfactory, he may make the payment directly to the contractor associated for minor component as per the terms and conditions of the agreement drawn between main contractor and associate contractor fixed by him. Such payment made to the associate contractor shall be recovered by Engineer-in-charge of major or minor component from the next R/A/ final bill due to main contractor as the case may be.

**No Running Account Bill shall be paid for the work till the applicable labour licenses, registration with EPFO, ESIC and BOCW Welfare Board, whatever applicable are submitted by the contractor to the Engineer-in-Charge.**

#### CLAUSE 8

**Completion  
Certificate  
and  
Completion  
Plans**

Within ten days of the completion of the work, the contractor shall give notice of such completion to the Engineer-in-Charge and within thirty days of the receipt of such notice, the Engineer-in-Charge shall inspect the work and if there is no defect in the work, shall furnish the contractor with a final certificate of completion, otherwise a provisional certificate of physical completion indicating defects (a) to be rectified by the contractor and/or (b) for which payment will be made at reduced rates, shall be issued. But no final certificate of completion shall be issued, nor shall the work be considered to be complete until the contractor shall have removed from the premises on which the work shall be executed all scaffolding, surplus materials, rubbish and all huts and sanitary arrangements required for his/their workpeople on the site in connection with the execution of the works as shall have been erected or constructed by the contractor(s) and cleaned off the dirt from all wood work, doors, windows, walls, floor or other parts of the building, in, upon, or about which the work is to be executed or of which he may have had possession for the purpose of the execution; thereof, and not until the work shall have been measured by the Engineer-in-Charge. If the contractor shall fail to comply with the requirements of this Clause as to removal of scaffolding, surplus materials and rubbish and all huts and sanitary arrangements as aforesaid and cleaning off dirt on or before the date fixed for the completion of work, the Engineer-in-Charge may at the expense of the contractor remove such scaffolding, surplus materials and rubbish etc., and dispose of the same as he thinks fit and clean off such dirt as aforesaid, and the contractor shall have no claim in respect of scaffolding or surplus materials as aforesaid except for any sum actually realized by the sale thereof.

#### CLAUSE 8A

**Contractor to  
Keep  
Site Clean**

When the annual repairs and maintenance of works are carried out, the splashes and droppings from white washing, colour washing, painting etc., on walls, floor, windows, etc. shall be removed and the surface cleaned simultaneously with the completion of these items of work in the individual rooms, quarters or premises etc. where the work is done: without waiting for the actual completion of all the other items of work in the contract. In case the contractor fails to comply with the requirements of this clause, the Engineer-in-Charge shall have the right to get this work done at the cost of the contractor either departmentally or through any other agency. Before taking such action, the Engineer-in-Charge shall give ten days' notice in writing to the contractor.

**Completion Plans to be Submitted by the Contractor**

**CLAUSE 8B**

The contractor shall submit completion plan as required vide General Specifications for Electrical works (Part-I Internal) 2013 and (Part-II External) 1994 as applicable within thirty days of the completion of the work.

The contractor shall submit completion plans for Internal and External Civil, Electrical and Mechanical Services, as applicable within thirty days of the completion of the work, provided that the service plans having been issued for execution by the Engineer-in-Charge, unless the contractor, by virtue of any other provision in the contract, is required to prepare such plans.

In case, the contractor fails to submit the completion plan within 30 days of completion of work or along with submission of final bill (whichever is later), he shall be liable to pay a sum **as prescribed in Schedule F** and in this respect the decision of the Engineer-in-charge shall be final and binding on the contractor.

**CLAUSE 9**

**Payment of Final Bill**

The final bill shall be submitted by the contractor in the same manner as specified in interim bills within three months of physical completion of the work or within one month of the date of the final certificate of completion furnished by the Engineer-in-Charge whichever is earlier. No further claims shall be made by the contractor after submission of the final bill and these shall be deemed to have been waived and extinguished. Payments of those items of the bill in respect of which there is no dispute and of items in dispute, for quantities and rates as approved by Engineer-in-Charge, will, as far as possible be made within the period specified hereinunder, the period being reckoned from the date of receipt of the bill by the Engineer-in-Charge or his authorized Assistant Engineer/ Executive Engineer, complete with account of materials issued by the Department and dismantled materials.

- (i) If the Tendered value of work is up to Rs. 45 lac : 2 months
- (ii) If the Tendered value of work is more than Rs.45 lac and up to Rs. 2.5 Crore: 3 months
- (iii) If the Tendered value of work exceeds Rs. 2.5 Crore : 6 months

**CLAUSE 9A**

**Payment of Contractor's Bills to Ban**

Payments due to the contractor may, if so desired by him, be made to his bank, registered financial, co-operative or thrift societies or recognized financial institutions instead of director him provided that the contractor furnishes to the Engineer-in-Charge (1) an authorization in the form of a

legally valid document such as a power of attorney conferring authority on the bank; registered financial, co-operative or thrift societies or recognized financial institutions to receive payments and (2) his own acceptance of the correctness of the amount made out as being due to him by Corporation or his signature on the bill or other claim preferred against Corporation before settlement by the Engineer-in-Charge of the account or claim by payment to the bank, registered financial, co-operative or thrift societies or recognized financial institutions. While the receipt given by such banks; registered financial, co-operative or thrift societies or recognized financial institutions shall constitute a full and sufficient discharge for the payment, the contractor shall whenever possible present his bills duly receipted and discharged through his bank, registered financial, co-operative or thrift societies or recognized financial institutions.

Nothing herein contained shall operate to create in favour of the bank; registered financial, co-operative or thrift societies or recognized financial institutions any rights or equities vis-a-vis the Corporation.

#### **CLAUSE 10**

**Materials  
supplied  
by  
Corporation**

Materials which Corporation will supply are shown in Schedule 'B' which also stipulates quantum, place of issue and rate(s) to be charged in respect thereof. The contractor shall be bound to procure them from the Engineer-in-Charge.

As soon as the work is awarded, the contractor shall finalise the programme for the completion of work as per clause 5 of this contract and shall give his estimates of materials required on the basis of drawings/or schedule of quantities of the work. The Contractor shall give in writing his requirement to the Engineer-in-Charge which shall be issued to him keeping in view the progress of work as assessed by the Engineer-in-Charge, in accordance with the agreed phased programme of work indicating monthly requirements of various materials. The contractor shall place his indent in writing for issue of such materials at least 7 days in advance of his requirement.

Such materials shall be supplied for the purpose of the contract only and the value of the materials so supplied at the rates specified in the aforesaid schedule shall be set off or deducted, as and when materials are consumed in items of work (including normal wastage for which payment is being made to the contractor, from any sum then due or which may therefore become due to the contractor under the contract or otherwise or from the security deposit. At the time of submission of bills, the contractor shall certify that balance of materials supplied is available at site in original good condition.

The contractor shall submit along with every running bill (on account or interim bill) material wise reconciliation statements supported by complete calculations reconciling total issue, total consumption and certified balance (diameter/section-wise in the case of steel) and resulting variations and reasons therefore. Engineer-in-Charge shall (whose decision shall be final and binding on the contractor) be within his rights to follow the procedure of recovery in clause 42 at any stage of the work if reconciliation is not found to be satisfactory.

The contractor shall bear the cost of getting the material issued, loading, transporting to site, unloading, storing under cover as required, cutting assembling and joining the several parts together as necessary. Notwithstanding anything to the contrary contained in any other clause of the contract and (or the CPWA Code) all stores/materials so supplied to the contractor or procured with the assistance of the Corporation shall remain the absolute property of Corporation and the contractor shall be the trustee of the stores/materials, and the said stores/materials shall not be removed/disposed off from the site of the work on any account and shall be at all times open to inspection by the Engineer-in-Charge or his authorized agent. Any such stores/materials remaining unused shall be returned to the Engineer-in-Charge in as good a condition in which they were originally supplied at a place directed by him, at a place of issue or any other place specified by him as he shall require, but in case it is decided not to take back the stores/materials the contractor shall have no claim for compensation on any account of such stores/materials so supplied to him as aforesaid and not used by him or for any wastage in or damage to in such stores/materials.

On being required to return the stores/materials, the contractor shall hand over the stores/materials on being paid or credited such price as the Engineer-in-Charge shall determine, having due regard to the condition of the stores/materials. The price allowed for credit to the contractor, however, shall be at the prevailing market rate not exceeding the amount charged to him, excluding the storage charge, if any. The decision of the Engineer-in-Charge shall be final and conclusive. In the event of breach of the aforesaid condition, the contractor shall in addition to throwing himself open to account for contravention of the terms of the licences or permit and/or for criminal breach of trust, be liable to Corporation for all advantages or profits resulting or which in the usual course would have resulted to him by reason of such breach. Provided that the contractor shall in no case be entitled to any compensation or damages on account of any delay in supply or non-supply thereof all or any such materials and stores provided further that the contractor shall be bound to execute the entire work if the materials are

supplied by the Corporation within the original scheduled time for completion of the work plus 50% thereof or schedule time plus 6 months whichever is more if the time of completion of work exceeds 12 months, but if a part of the materials only has been supplied within the aforesaid period, then the contractor shall be bound to do so much of the work as may be possible with the materials and stores supplied in the aforesaid period. For the completion of the rest of the work, the contractor shall be entitled to such extension of time as may be determined by the Engineer-in-Charge whose decision in this regard shall be final and binding on the contractor.

The contractor shall see that only the required quantities of materials are got issued. Any such material remaining unused and in perfectly good/original condition at the time of completion or determination of the contract shall be returned to the Engineer-in-Charge at the stores from which it was issued or at a place directed by him by a notice in writing. The contractor shall not be entitled for loading, transporting, unloading and stacking of such unused material except for the extra lead, if any involved, beyond the original place of issue.

#### **CLAUSE 10A**

**Materials to be provided by the Contractor**

The contractor shall, at his own expense, provide all materials, required for the works other than those which are stipulated to be supplied by the Corporation.

The contractor shall, at his own expense and without delay, supply to the Engineer-in-Charge samples of materials to be used on the work and shall get these approved in advance. All such materials to be provided by the Contractor shall be in conformity with the specifications laid down or referred to in the contract. The contractor shall, if requested by the Engineer-in-Charge furnish proof, to the satisfaction of the Engineer-in-Charge that the materials so comply. The Engineer-in-Charge shall within thirty days of supply of samples or within such further period as he may require intimate to the Contractor in writing whether samples are approved by him or not. If samples are not approved, the Contractor shall forthwith arrange to supply to the Engineer-in-Charge for his approval, fresh samples complying with the specifications laid down in the contract. When materials are required to be tested in accordance with specifications, approval of the Engineer-in-Charge shall be issued after the test results are received.

The Contractor shall at his risk and cost submit the samples of materials to be tested reanalysed and shall not make use of or incorporate in the work any materials represented by the samples until the required tests or analysis have been made and materials finally accepted by the Engineer-in-Charge. The Contractor shall not be eligible for any claim or compensation either arising

out of any delay in the work or due to any corrective measures required to be taken on account of and as a result of testing of materials.

The contractor shall, at his risk and cost, make all arrangements and shall provide all facilities as the Engineer-in-Charge may require for collecting, and preparing the required number of samples for such tests at such time and to such place or places as may be directed by the Engineer-in-Charge and bear all charges and cost of testing unless specifically provided for otherwise elsewhere in the contract or specifications. The Engineer in- Charge or his authorized representative shall at all times have access to the works and to all workshops and places where work is being prepared or from where materials, manufactured articles or machinery are being obtained for the works and the contractor shall afford every facility and every assistance in obtaining the right to such access.

The Engineer-in-Charge shall have full powers to require the removal from the premises of all materials which in his opinion are not in accordance with the specifications and in case of default, the Engineer-in-Charge shall be at liberty to employ at the expense of the contractor, other persons to remove the same without being answerable or accountable for any loss or damage that may happen or arise to such materials. The Engineer-in-Charge shall also have full powers to require other proper materials to be substituted thereof and in case of default, the Engineer-in-Charge may cause the same to be supplied and all costs which may attend such removal and substitution shall be borne by the Contractor.

The contractor shall at his own expense, provide a material testing lab at the site for conducting routine field tests. The lab shall be equipped at least with the testing equipment as specified in schedule F.

#### **CLAUSE 10B**

**Secured  
Advance  
on Non-  
perishable  
Materials**

(i) The contractor, on signing an indenture in the form **in Appendix XVIII** by the Engineer-in-Charge, shall be entitled to be paid during the progress of the execution of the work **up to 75% of the assessed value** of any materials which are in the opinion of the Engineer-in- Charge non-perishable, non-fragile and non-combustible and are in accordance with the contract and which have been brought on the site in connection therewith and are adequately stored and/or protected against damage by weather or other causes but which have not at the time of advance been incorporated in the works. When materials on account of which an advance has been made under this sub-clause are incorporated in the work, the amount of such advance shall be recovered/deducted from the next payment made under any of the clause or clauses of this contract.

Such secured advance shall also be payable on other items of perishable nature, fragile and combustible with the approval of the Engineer-in-Charge provided the contractor provides a comprehensive insurance cover for the full cost of such materials. The decision of the Engineer- in-Charge shall be final and binding on the contractor in this matter. No secured advance, shall however, be paid on high-risk materials such as ordinary glass, sand, petrol, diesel etc.

**Mobilisation  
Advance**

**DELETED**

~~(ii) Mobilization advance not exceeding 10% of the tendered value may be given, if requested by the contractor in writing within one month of the order to commence the work. Such advance shall be in two or more instalments to be determined by the Engineer in Charge at his sole discretion. The first instalment of such advance shall be released by the Engineer in-charge to the contractor on a request made by the contractor to the Engineer in Charge in this behalf. The second and subsequent instalments shall be released by the Engineer in Charge only after the contractor furnishes a proof of the satisfactory utilization of the earlier instalment to the entire satisfaction of the Engineer in-Charge.~~

~~Before any instalment of advance is released, the contractor shall execute a Bank Guarantee Bond not more than 6 in number from Scheduled Bank for the amount equal to 110% of the amount of advance and valid for the period till recovery of advance. This (Bank Guarantee from Scheduled Bank for the amount equal to 110% of the balance amount of advance) shall be kept renewed from time to time to cover the balance amount and likely period of complete recovery.~~

~~Provided always that provision of Clause 10 B (ii) shall be applicable only when so provided in 'Schedule F'.~~

**Plant  
Machinery &  
Shuttering  
Material  
Advance**

**DELETED**

~~(iii) An advance for plant, machinery & shuttering material required for the work and brought to site by the Contractor may be given if requested by the contractor in writing within one month of bringing such plant and machinery to site. Such advance shall be given on such plant and machinery which in the opinion of the Engineer in charge will add to the expeditious execution of work and improve the quality of work. The amount of advance shall be restricted to 5% percent of the tender value. In the case of new plant and equipment to be purchased for the work, the advance shall be restricted to 90% of the price of such new plant and equipment paid by the contractor for which the contractor shall produce evidence satisfactory to the Engineer in-Charge. In the case of second hand and used plants and equipment, the amount of such advance shall be limited to 50% of the depreciated value of~~



~~plant and equipment as may be decided by the Engineer in Charge. The contractor shall, if so required by the Engineer in Charge, submit the statement of value of such old plant and equipment duly approved by a Registered Valuer recognized by the Central Board of Direct Taxes under the Income Tax Act, 1961. No such advance shall be paid on any plant and equipment of perishable nature and on any plant and equipment of a value less than Rs. 50,000/- Seventy five per cent of such amount of advance shall be paid after the plant & equipment is brought to site and balance twenty-five percent on successfully commissioning the same.~~

~~Leasing of equipment shall be considered at par with purchase of equipment and shall be covered by tripartite agreement with the following:~~

- ~~1. Leasing company which gives certificate of agreeing to lease equipment to the contractor.~~
- ~~2. Engineer in Charge, and~~
- ~~3. The contractor.~~

~~This advance shall further be subject to the condition that such plant and equipment (a) are considered by the Engineer in Charge to be necessary for the works; (b) and are in working order and are maintained in working order; (c) hypothecated to the Corporations specified by the Engineer in Charge before the payment of advance is released. The contractor shall not be permitted to remove from the site such hypothecated plant and equipment without the prior written permission of the Engineer in Charge. The contractor shall be responsible for maintaining such plant and equipment in good working order during the entire period of hypothecation failing which such advance shall be entirely recovered in lump sum. For this purpose, steel scaffolding and form work shall be treated as plant and equipment.~~

~~The contractor shall insure the Plant and Machinery for which mobilization advance is sought and given, for a sum sufficient to provide for their replacement at site. Any amounts not recovered from the insurer will be borne by the contractor.~~

**Interest &  
Recovery**

**~~DELETED~~**

~~(iv) The mobilization advance and plant and machinery advance in (ii)&(iii) above bear simple interest at the rate of 10 per cent per annum and shall be calculated from the date of payment to the date of recovery, both days inclusive, on the outstanding amount of advance. Recovery of such sums advanced shall be made by the deduction from the contractor's bills commencing after first ten per cent of the gross value of the work is executed and paid, on pro-rata percentage basis to the gross value of the work billed beyond 10% in such a way that the entire advance is recovered by the time eighty percent of the gross value of the contract is executed and paid,~~

~~together with interest due on the entire outstanding amount up to the date of recovery of the instalment.~~

~~(v) If the circumstances are considered reasonable by the Engineer in Charge, the period mentioned in (ii) and (iii) for request by the contractor in writing for grant of mobilization advance and plant and equipment advance may be extended in the discretion of the Engineer in Charge.~~

#### **CLAUSE 10C DELETED**

**Payment on  
Account of  
Increase in  
Prices/Wages  
due to  
Statutory  
Order(s)**

~~If after submission of tender, if the price of any material incorporated in the works (excluding the materials covered under Clause 10CA and not being a material supplied from the Engineer in Charge's stores in accordance with Clause 10 thereof) and/or wages of labour increases as a direct result of the coming into force of any fresh law, or statutory rule or order (but not due to any variation of rates in GST applicable on such material(s) being considered under this clause) beyond the prices/wages prevailing at the time of the last stipulated date of receipt of tenders including extensions, if any, for the work during contract period including the justified period extended under the provisions of clause 5 of the contract without any action under clause 2, then the amount of the contract shall accordingly be varied.~~

~~If after submission of the tender, the price of any material incorporated in the works (excluding the materials covered under Clause 10CA and not being a material supplied from the Engineer in Charge's stores in accordance with Clause 10 thereof) and/or wages of labour as prevailing at the time of last stipulated date of receipt of tender including extensions, if any, is decreased as a direct result of the coming into force of any fresh law or statutory rules or order (but not due to any changes of rate in sales tax/VAT, Central/State Excise/Custom Duty), shall in respect of materials incorporated in the works (excluding the materials covered under Clause 10CA and not being material supplied from the Engineer in Charge's stores in accordance with Clause 10 hereof) and/or labour engaged on the execution of the work after the date of coming into force of such law statutory rule or order be entitled to deduct from the dues of the contractor, such amount as shall be equivalent to the difference between the prices of the materials and/or wages as prevailed at the time of the last stipulated date for receipt of tenders including extensions if any for the work and the prices of materials and/or wages of labour on the coming into force of such law, statutory rule or order. This will be applicable for the contract period including the justified period extended under the provisions of clause 5 of the contract without any action under clause 2.~~

~~Engineer in Charge shall call books of account and other relevant documents from the contractor to satisfy himself about reasonability of increase in prices of materials and wages.~~

~~The contractor shall, within a reasonable time of his becoming aware of any alteration in the price of any such materials and/or wages of labour, give notice thereof to the Engineer in Charge stating that the same is given pursuant to this condition together with all information relating thereto which he may be in position to supply.~~

~~For this purpose, the labour component of 85% of the value of the work executed during period under consideration shall not exceed the percentage as specified in Schedule F, and the increase/decrease in labour shall be considered on the minimum daily wages in rupees of any unskilled mazdoor, fixed under any law, statutory rule or order.~~

~~The cost of work for which escalation is applicable (W) is same as cost of work done worked out as indicated in sub-para (ii) of Clause 10CC except the amount of full assessed value of secured advance.~~

#### **CLAUSE 10 CA DELETED**

**Payment due to variation in prices of materials after receipt of tender**

~~If after submission of the tender, the price of materials specified in Schedule F increases/decreases beyond the base price(s) as indicated in Schedule F for the work, then the amount of the contract shall accordingly be varied and provided further that any such variations shall be effected for stipulated period of Contract including the justified period extended under the provisions of Clause 5 of the Contract without any action under Clause 2.~~

~~However, for work done/during the justified period extended as above, it will be limited to indices prevailing at the time of updated stipulated date of completion considering the effect of extra work (extra time to be calculated on pro-rata basis only as cost of extra work stipulated period/tendered cost).~~

~~The increase/decrease in prices of cement, steel reinforcement, structural steel and Postal be determined by the Price indices issued by the **Director General, CPWD**. For other items provided in the Schedule 'F', this shall be determined by the All India Wholesale Price Indices of materials as published by Economic Advisor to Government of India, Ministry of Commerce and Industry. Base price for cement, steel reinforcement, structural steel shall be as issued under the authority of **Director General CPWD** applicable for Delhi including Noida, Gurgaon, Faridabad & Ghaziabad and for other places as issued under the authority of **Zonal Chief Engineer, CPWD** and base price of other materials issued by concerned Zonal Chief Engineer and as indicated in Schedule 'F'. In case, price index of a particular material is not issued by Ministry of Commerce and Industry, then the price index of nearest similar material as indicated in Schedule 'F' shall be followed.~~

~~The amount of the contract shall accordingly be varied for all such materials and will be worked out as per the formula given below for individual material:~~

-

Adjustment for component of individual material

$$\frac{V - P \times Q \times \frac{CI - C_{10}}{C_{10}}}{C_{10}}$$

where,

V = Variation in material cost i.e. increase or decrease in the amount of rupees to be paid or recovered.

P = Base Price of material as issued under authority of **DG, CPWD** or concerned Zonal Chief Engineer and as indicated in Schedule "F".

For Projects and Original Works

Q = Quantity of material brought at site for bonafide use in the works since previous bill excluding any such quantity consumed in the deviated quantity of items beyond deviation limit and extra /substituted item, paid/to be paid at rates derived on the basis of market rate under clause 12.2.

For Maintenance Works

Q = Quantity of material brought at site for bonafide use in the works since previous bill including any such quantity consumed in the deviated quantity of items beyond deviation limit paid at agreement rate and extra /substituted item being scheduled items, but excluding non-scheduled extra /substituted item paid/to be paid at market rate under clause 12.2.

C<sub>10</sub> = Price index for cement, steel reinforcement bars structural steel and POL as issued by the DG, CPWD and corresponding to the time of base price of respective material indicated in Schedule 'F'. For other items, if any, provided in Schedule 'F', All India Wholesale Price Index for the material as published by the Economic Advisor to Government of India, Ministry of Industry and Commerce and corresponding to the time of base price of respective material indicated in Schedule 'F'.

CI = Price index for cement, steel reinforcement bars, structural steel and POL as issued under the authority of DG, CPWD for period under consideration. For other items, if any, provided in Schedule 'F', All India Wholesale Price Index for the material for period under consideration as published by Economic Advisor to Government of India, Ministry of Industry and Commerce.

Note: (i) In respect of the justified period extended under the provisions of

~~clause 5 of the contract without any action under clause 2, the index prevailing at the time of updated stipulated date of completion considering the effect of extra work (extra time to be calculated on prorata basis only as cost of extra work x stipulated period/tendered cost) shall be considered.~~

~~Provided always that provisions of the preceding Clause 10 C shall not be applicable in respect of Materials covered in this Clause.~~

~~(ii) If during progress of work or at the time of completion of work, it is noticed that any material brought at site is in excess of requirement, then amount of escalation if paid earlier on such excess quantity of material shall be recovered on the basis of cost indices as applied at the time of payment of escalation or as prevailing at the time of effecting recovery, whichever is higher.~~

~~(iii) Cement mentioned wherever in this clause includes Cement component used in RMC brought at site from outside approved RMC plants, if any.~~

~~(iv) The date wise record of ready mix concrete shall be kept in a register and the cement consumption for the same shall be calculated accordingly.~~

~~(v) If built up steel items are brought at site from workshop, then the variation shall be paid for the structural steel up to the period when the built up item/finished product is brought at site.~~

#### **CLAUSE 10 CC DELETED**

<b>Payment due to Increase/Decrease in Prices/Wages (excluding materials covered under clause 10 CA) after Receipt of Tender for Works</b>	<del>If the prices of materials (not being materials supplied or services rendered at fixed prices by the department in accordance with clause 10 &amp; 34 thereof) and/or wages of labour required for execution of the work increase, the contractor shall be compensated for such increase as per provisions detailed below and the amount of the contract shall accordingly be varied, subject to the condition that that such compensation for escalation in prices and wages shall be available only for the work done during the stipulated period of the contract including the justified period extended under the provisions of clause 5 of the contract without any action under clause 2. No such compensation shall be payable for a work for which the stipulated period of completion is equal to or less than the time as specified in Schedule F. Such compensation for escalation in the prices of materials and labour, when due, shall be worked out based on the following provisions:-  (i) The base date for working out such escalation shall be the last stipulated</del>
--	--

date of receipt of tenders including extension, if any.

~~(ii) The cost of work on which escalation will be payable shall be reckoned as below:-~~

~~(a) Gross value of work done up to this quarter : \_\_\_\_\_ (A)~~

~~(b) Gross value of work done up to the last quarter : (B)~~

~~(c) Gross value of work done since previous quarter (A-B) (C)~~

~~(d) Full assessed value of Secured Advance (excluding materials Covered under Clause 10 CA) fresh paid in this quarter : (D)~~

~~(e) Full assessed value of Secured Advance (excluding materials Covered under Clause 10 CA) recovered in this quarter : \_\_\_\_\_ (E)~~

~~(f) Full assessed value of Secured Advance for which escalation  
\_\_\_\_\_ Payable in this quarter (D-E): \_\_\_\_\_ (F)~~

~~(g) Advance payment made during this quarter: \_\_\_\_\_ (G)~~

~~(h) Advance payment recovered during this quarter: \_\_\_\_\_ (H)~~

~~(i) Advance payment for which escalation is payable in this Quarter (G-H):~~

~~(j) Extra items/deviated quantities of items paid as per Clause 12  
\_\_\_\_\_ Based on prevailing market rates during this quarter: \_\_\_\_\_ (J)~~

~~Then, M = C+F+I+J~~

~~\_\_\_\_\_ N = 0.85 M~~

~~(k) Less cost of material supplied by the department as per  
Clause 10 and recovered during the quarter \_\_\_\_\_ (K)~~

~~(l) Less cost of services rendered at fixed charges as per Clause  
34 and recovered during the quarter \_\_\_\_\_ (L)~~

~~Cost of work for which escalation is applicable:~~

~~\_\_\_\_\_ W = N - (K + L)~~

~~(iii) Components for materials (except cement, reinforcement bars, structural steel, POL or other materials covered under clause 10 CA) labour, etc. shall be pre-determined forever work and incorporated in the conditions of contract attached to the tender papers included in Schedule 'F'. The decision of the Engineer-in-Charge in working out such percentage shall be binding on the contractors.~~

~~(iv) The compensation for escalation for other materials (excluding cement, reinforcement bars, structural steel, POL or other materials covered under clause 10 CA) shall be worked as per the formula given below:-~~

~~(a) Adjustment for civil component (except cement, structural steel, reinforcement bars, POL and other materials covered under clause 10CA) /~~

electrical component of construction 'Materials'

$$V_m = \frac{W \times X_m \times MI - MI_o}{100 \times MI_o}$$

~~V<sub>m</sub> = Variation in material cost i.e. increase or decrease in the amount in rupees to be paid or recovered.~~

~~W = Cost of Work done worked out as indicated in sub-para (ii) of Clause 10CC.~~

~~X<sub>m</sub> = Component of 'materials' (except cement, structural steel, reinforcement bars POL and other materials covered under clause 10CA) expressed as percent of the total value of work.~~

~~MI = All India Wholesale Price Index for civil component/electrical component\* of construction material as worked out on the basis of All India Wholesale~~

~~Price Index for Individual Commodities/ Group Items for the period under consideration as published by Economic Advisor to Govt. of India, Ministry of Industry & Commerce and applying weightages to the Individual Commodities/Group Items. (In respect of the justified period extended under the provisions of clause 5 of the contract without any action under clause 2, the index prevailing at the time of updated stipulated date of completion considering the effect of extra work (extra time to be calculated on prorata basis only as cost of extra work x stipulated period/tendered cost, shall be considered.)~~

~~MI<sub>o</sub> = All India Wholesale Price Index for civil component/electrical component\* of construction material as worked out on the basis of All India Wholesale Price Index for Individual Commodities/Group Items valid on the last stipulated date of receipt of tender including extension, if any, as published by the Economic Advisor to Govt. of India, Ministry of Industry & Commerce and applying weightages to the Individual Commodities/Group items.~~

**\*Note:** relevant component only will be applicable.

~~(v) The following principles shall be followed while working out the indices mentioned in para (iv) above.~~

~~(a) The compensation for escalation shall be worked out at quarterly intervals and shall be with respect to the cost of work done as per bills paid during the three calendar months of the said quarter. The dates of~~

~~preparation of bills as finally entered in the Measurement Book by the Assistant Engineer/ date of submission of bill finally by the contractor to the department in case of computerised measurement books shall be the guiding factor to decide the bills relevant to the quarterly interval. The first such payment shall be made at the end of three months after the month (excluding the month in which tender was accepted) and thereafter at three months' interval. At the time of completion of the work, the last period for payment might become less than 3 months, depending on the actual date of completion.~~

~~(b) The index (MI/Fl etc.) relevant to any quarter/period for which such compensation is paid shall be the arithmetical average of the indices relevant to the three calendar months. If the period up to date of completion after the quarter covered by the last such instalment of payment, is less than three months, the index MI and FL shall be the average of the indices for the months falling within that period.~~

~~(vi) The compensation for escalation for labour shall be worked out as per the formula given below:-~~

$$\frac{VL}{100} = \frac{W \times Y}{100} \times \frac{LI - LI_0}{LI_0}$$

~~VL : Variation in labour cost i.e. amount of increase or decrease in rupees To be paid or recovered.~~

~~W : Value of work done, worked out as indicated in sub-para (ii) above.~~

~~Y : Component of labour expressed as a percentage of the total value of the work.~~

~~LI : Minimum wage in rupees of an unskilled adult male mazdoor, fixed under any law, statutory rule or order as applicable on the last date of the quarter previous to the one under consideration. (In respect of the justified period extended under the provisions of clause 5 of the contract without any action under clause 2, the minimum wage prevailing on the last date of quarter previous to the quarter pertaining to updated stipulated date of Completion considering the effect of extra work (extra time to be calculated on prorata basis only as cost of extra work x stipulated period/tendered cost, shall be considered.)~~

~~LI<sub>0</sub> : Minimum daily wage in rupees of an unskilled adult male mazdoor, fixed under any law, statutory rule or order as on the last stipulated date of receipt of tender including extension, if any.~~



~~(vii) The following principles will be followed while working out the compensation as per subpara (vi) above.~~

~~(a) The minimum wage of an unskilled mazdoor mentioned in sub-para (vi) above shall be the higher of the wage notified by Government of India, Ministry of Labour and that notified by the local administration both relevant to the place of work and the period of reckoning.~~

~~(b) The escalation for labour also shall be paid at the same quarterly intervals when escalation due to increase in cost of materials is paid under this clause. If such revision of minimum wages takes place during any such quarterly intervals, the escalation compensation shall be payable at revised rates only for work done in subsequent quarters;~~

~~(c) Irrespective of variations in minimum wages of any category of labour, for the purpose of this clause, the variation in the rate for an unskilled mazdoor alone shall form the basis for working out the escalation compensation payable on the labour component.~~

~~(viii) In the event the price of materials and/or wages of labour required for execution of the work decrease/s, there shall be a downward adjustment of the cost of work so that such price of materials and/or wages of labour shall be deductible from the cost of work under this contract and in this regard the formula herein before stated under this Clause 10CC shall mutatis mutandis apply, provided that:~~

~~(a) no such adjustment for the decrease in the price of materials and/or wages of labour afore-mentioned would be made in case of contracts in which the stipulated period of completion of the work is equal to or less than the time as specified in Schedule 'F'.~~

~~(b) the Engineer in Charge shall otherwise be entitled to lay down the procedure by which the provision of this sub-clause shall be implemented from time to time and the decision of the Engineer in Charge in this behalf shall be final and binding on the contractor.~~

~~(ix) Provided always that:-~~

~~(a) Where provisions of clause 10CC are applicable, provisions of clause 10C will not be applicable but provisions of clause 10CA will be applicable.~~

~~(b) Where provisions of clause 10CC are not applicable, provisions of clause 10C and 10CA will become applicable.~~

~~**Note:** Updated stipulated date of completion (period of completion plus extra time for extra work for compensation under clause 10C, 10CA and 10CC, the factor of 1.25 taken into account for calculating the extra time under clause 12.1 for extra time shall not be considered while calculating the updated~~

~~stipulated date of completion for this purpose in clause 10C, clause 10CA, and clause 10CC.~~

#### **CLAUSE 10 D**

**Dismantled Material Govt. Property** The contractor shall treat all materials obtained during dismantling of a structure, excavation of the site for a work, etc. as Corporation's property and such materials shall be disposed off to the best advantage of Corporation according to the instructions in writing issued by the Engineer-in-Charge.

#### **CLAUSE 11**

**Work to be executed in accordance with specifications, drawings, orders etc.** The contractor shall execute the whole and every part of the work in the most substantial and workman like manner both as regards materials and otherwise in every respect in strict accordance with the specifications. The contractor shall also conform exactly, fully and faithfully to the design, drawings and instructions in writing in respect of the work signed by the Engineer-in-Charge and the contractor shall be furnished free of charge one copy of the contract documents together with specifications, designs, drawings and instructions as are not included in the standard specifications of Central Public Works Department specified in Schedule 'F' or in any Bureau of Indian Standard or any other, published standard or code or, Schedule of Rates or any other printed publication referred to elsewhere in the contract.

The contractor shall comply with the provisions of the contract and with the care and diligence execute and maintain the works and provide all labour and materials, tools and plants including for measurements and supervision of all works, structural plans and other things of temporary or permanent nature required for such execution and maintenance in so far as the necessity for providing these, is specified or is reasonably inferred from the contract. The Contractor shall take full responsibility for adequacy, suitability and safety of all the works and methods of construction.

#### **CLAUSE 12 :**

**Deviations/ Variations Extent and Pricing** The Engineer-in-Charge shall have power (i) to make alteration in, omissions from, additions to, or substitutions for the original specifications, drawings, designs and instructions that may appear to him to be necessary or advisable during the progress of the work, and (ii) to omit a part of the works in case of non-availability of a portion of the site or for any other reasons and the contractor shall be bound to carry out the works in accordance with any instructions given to him in writing signed by the Engineer-in-Charge and such alterations, omissions, additions or substitutions shall form part of the contract as if originally provided therein and any altered, additional or

substituted work which the contractor may be directed to do in the manner specified above as part of the works, shall be carried out by the contractor on the same conditions in all respects including price on which he agreed to do the main work except as hereafter provided.

The completion cost of any agreement for Maintenance works including works of upgradation, aesthetic, special repair, addition/ alteration shall not exceed 1.25 times of Tendered amount. Any further deviation beyond this limit up to 1.5 times of tendered amount shall be approved by Chief Engineer with recorded reason and in exceptional case, Chief Engineer shall have full power to approve the deviation beyond 1.50 times of tendered amount with recorded reason and take suitable corrective action.

- 12.1** The time for completion of the works shall, in the event of any deviations resulting in additional cost over the tendered value sum being ordered, be extended, if requested by the contractor, as follows
- (i) In the proportion which the additional cost of the altered, additional or substituted work, bears to the original tendered value plus
  - (ii) 25% of the time calculated in (i) above or such further additional time as may be considered reasonable by the Engineer-in-Charge.

**12.2** A. For Project and original works:

**Deviation,  
Extra  
Items and  
Pricing**

In the case of extra item(s) (items that are completely new, and are in addition to the items contained in the contract), the contractor may within fifteen days of receipt of order or occurrence of the item(s) claim rates, supported by proper analysis which shall include invoices, vouchers etc. and Manufacturer's specification for the work failing which the rate approved later by the Engineer-in-charge shall be binding and the Engineer-in-charge shall within prescribed time limit of the receipt of the claims supported by analysis, after giving consideration to the analysis of the rates submitted by the contractor, determine the rates on the basis of the market rates and the contractor shall be paid in accordance with the rates so determined, failing which it will be deemed to have been approved.

B. For Maintenance works including works of upgradation, aesthetic, special repair, addition/ alteration:

In the case of Extra Item(s) being the schedule items (Delhi Schedule of Rates items), these shall be paid as per the schedule rate plus/minus percentage above/ below quoted contract amount. Payment of Extra items in case of non-schedule items (Non-DSR items) shall be made as per the prevailing market rate.

A. For Project and original works:

**Deviation,  
Substituted  
Items,  
Pricing**

In the case of substituted items (items that are taken up with partial substitution Orin lieu of items of work in the contract), the rate for the agreement item (to be substituted) and substituted item shall also be determined in the manner as mentioned in the following para.

(a) If the market rate for the substituted item so determined is more than the market rate of the agreement item (to be substituted), the rate payable to the contractor for the substituted item shall be the rate for the agreement item (To be substituted) so increased to the extent of the difference between the market rates of substituted item and the agreement item (to be substituted).

(b) If the market rate for the substituted item so determined is less than the market rate of the agreement item (to be substituted), the rate payable to the contractor for the substituted item shall be the rate for the agreement item (To be substituted) so decreased to the extent of the difference between the market rates of substituted item and the agreement item (to be substituted).

B. For Maintenance works including works of upgradation, aesthetic, special repair, addition/ alteration:

In the case of Substitute Item(s) being the schedule items (Delhi Schedule of Rates items), these shall be paid as per the schedule rate plus/minus percentage above/ below quoted contract amount.

Payment of Substitute in case of non-schedule items (Non-DSR items) shall be made as per the prevailing market rate.

A. For Project and original works:

**Deviation,  
Deviated  
Quantities,  
Pricing**

In the case of contract items, substituted items, contract cum substituted items, which exceed the limits laid down in schedule F, the contractor may within fifteen days of receipt of order or occurrence of the excess, claim revision of the rates, supported by proper analysis for the work in excess of the above mentioned limits, provided that if the rates so claimed are in excess of the rates specified in the schedule of quantities, the Engineer-in-Charge shall within prescribed time limit of receipt of the claims supported by analysis, after giving consideration to the analysis of the rates submitted by the contractor, determine the rates on the basis of the market rates and the contractor shall be paid in accordance with the rates so determined.

B. For Maintenance works including works of upgradation, aesthetic, special repair, addition/ alteration:

In the case of contract items, which exceed the limits laid down in schedule F, the contractor shall be paid rates at Agreement rate/ Market rate whichever

is lower. The prescribed time limits for finalising rates for Extra Item(s), Substitute Item(s) and Deviated Quantities of contract items is within 30 days after submission of proposal by the contractor without observation of the Engineer-in-Charge.

**12.3** A. For Project and original works:

The provisions of the preceding paragraph shall also apply to the decrease in the rates of items for the work in excess of the limits laid down in Schedule F, and the Engineer-in-Charge shall after giving notice to the contractor within one month of occurrence of the excess and after taking into consideration any reply received from him within fifteen days of the receipt of the notice, revise the rates for the work in question within one month of the expiry of the said period of fifteen days having regard to the market rates.

B. For Maintenance works including works of upgradation, aesthetic, special repair, addition/ alteration:

In case of decrease in the rates prevailing in the market of items for the work in excess of the limits laid down in Schedule F, the Engineer-in-Charge shall after giving notice to the contractor within one month of occurrence of the excess and after taking into consideration any reply received from him within fifteen days of the receipt of the notice, revise the rates for the work in question within one month of the expiry of the said period of fifteen days having regard to the market rates.

**12.4** The contractor shall send to the Engineer-in-Charge once every three months, an up to date account giving complete details of all claims for additional payments to which the contractor may consider himself entitled and of all additional work ordered by the Engineer-in-Charge which he has executed during the preceding quarter failing which the contractor shall be deemed to have waived his right. However, the Superintending Engineer may authorise consideration of such claims on merits.

**12.5** For the purpose of operation of Schedule "F", the following works shall be treated as works relating to foundation unless & otherwise defined in the contract:

(i) For Buildings : All works up to 1.2 metres above ground level or up to floor 1 level whichever is lower.

(ii) For abutments, piers and well staining : All works up to 1.2 m above the bed level.

(iii) For retaining walls, wing walls, compound walls, chimneys, overhead reservoirs/tanks and other elevated structures: All works up to 1.2 metres above the ground level.

(iv) For reservoirs/tanks (other than overhead reservoirs/tanks): All works up to 1.2metres above the ground level.

(v) For basement: All works up to 1.2 m above ground level or up to floor 1 level whichever is lower.

(vi) For Roads, all items of excavation and filling including treatment of sub base.

- 12.6** Any operation incidental to or necessarily has to be in contemplation of tenderer while filing. tender, or necessary for proper execution of the item included in the Schedule of quantities or in the schedule of rates mentioned above, whether or not, specifically indicated in the description of the item and the relevant specifications, shall be deemed to be included in the rates quoted by the tenderer or the rate given in the said schedule of rates, as the case may be. Nothing extra shall be admissible for such operations.

### **CLAUSE 13**

**Foreclosure  
of  
contract due  
to  
Abandonmen  
t or  
Reduction in  
Scope of  
Work**

If at any time after acceptance of the tender or during the progress of work, the purpose or object for which the work is being done changes due to any supervening cause and as a result of which the work has to be abandoned or reduced in scope the Engineer-in-Charge shall give notice in writing to that effect to the contractor stating the decision as well as the cause for such decision and the contractor shall act accordingly in the matter. The contractor shall have no claim to any payment of compensation or otherwise whatsoever, on account of any profit or advantage which he might have derived from the execution of the works in full but which he did not derive in consequence of the foreclosure of the whole or part of the works.

The contractor shall be paid at contract rates, full amount for works executed at site and, in addition, a reasonable amount as certified by the Engineer-in-Charge for the items hereunder mentioned which could not be utilized on the work to the full extent in view of the foreclosure;

(i) Any expenditure incurred on preliminary site work, e.g. temporary access roads, temporary labour huts, staff quarters and site office; storage accommodation and water storage tanks.

(ii) Corporation shall have the option to take over contractor's materials or any part thereof either brought to site or of which the contractor is legally bound to accept delivery from suppliers (for incorporation in or incidental to the work) provided, however Corporation shall be bound to take over the materials or such portions thereof as the contractor does not desire to retain.

For materials taken over or to be taken over by Corporation, cost of such materials as detailed by Engineer-in- Charge shall be paid. The cost shall, however, take into account purchase price, cost of transportation and deterioration or damage which may have been caused to materials whilst in the custody of the contractor.

(iii) If any materials supplied by Corporation are rendered surplus, the same except normal wastage shall be returned by the contractor to Corporation at rates not exceeding those at which these were originally issued, less allowance for any deterioration or damage which may have been caused whilst the materials were in the custody of the contractor. In addition, cost of transporting such materials from site to Corporation stores, if so required by Corporation, shall be paid.

(iv) Reasonable compensation for transfer of T & P from site to contractor's permanent stores or to his other works, whichever is less. If T & P are not transported to either of the said places, no cost of transportation shall be payable.

(v) Reasonable compensation for repatriation of contractor's site staff and imported labour to the extent necessary.

The contractor shall, if required by the Engineer- in-Charge, furnish to him, books of account, wage books, time sheets and other relevant documents and evidence as may be necessary to enable him to certify the reasonable amount payable under this condition.

The reasonable amount of items on (i), (iv) and (v) above shall not be in excess of 2% of the cost of the work remaining incomplete on the date of closure, i.e. total stipulated cost of the work as per accepted tender less the cost of work actually executed under the contract and less the cost of contractor's materials at site taken over by the Corporation as per item (ii) above. Provided always that against any payments due to the contractor on this account or otherwise, the Engineer-in-Charge shall be entitled to recover or be credited with any outstanding balances due from the contractor for advance paid in respect of any tool, plants and materials and any other sums which at the date of termination were recoverable by the Corporation from the contractor under the terms of the contract.

In the event of action being taken under Clause 13 to reduce the scope of work, the contractor may furnish fresh Performance Guarantee on the same conditions, in the same manner and at the same rate for the balance tendered amount and initially valid up to the extended date of completion or stipulated date of completion if no extension has been granted plus 60 days beyond that. Wherever such a fresh Performance Guarantee is furnished by

the contractor the Engineer-in-Charge may return the previous Performance Guarantee.

#### **Clause 14**

**Carrying out part work at risk & cost of contractor**

If contractor:

(i) At any time makes default during currency of work or does not execute any part of the work with due diligence and continues to do so even after a notice in writing of 7 days in this respect from the Engineer-in-Charge; or

(ii) Commits default in complying with any of the terms and conditions of the contract and does not remedy it or takes effective steps to remedy it within 7 days even after a notice in writing is given in that behalf by the Engineer-in-Charge; or

Fails to complete the work(s) or items of work with individual dates of completion, on or before the date(s) so determined, and does not complete them within the period specified in the notice given in writing in that behalf by the Engineer-in-Charge.

The Engineer- in-Charge without invoking action under clause 3 may, without prejudice to another right or remedy against the contractor which have either accrued or accrue thereafter to Corporation, by a notice in writing to take the part work / part incomplete work of any item(s)out of his hands and shall have powers to:

(a) Take possession of the site and any materials, constructional plant, implements, stores, etc., thereon; and/or

(b) Carry out the part work / part incomplete work of any item(s) by any means at the risk and cost of the contractor.

The Engineer-in-Charge shall determine the amount, if any, is recoverable from the contractor for completion of the part work/ part incomplete work of any item(s) taken out of his hands and execute at the risk and cost of the contractor, the liability of contractor on account of loss or damage suffered by Corporation because of action under this clause shall not exceed10% of the tendered value of the work.

In determining the amount, credit shall be given to the contractor with the value of work done in all respect in the same manner and at the same rate as if it had been carried out by the original contractor under the terms of his contract, the value of contractor's materials taken over and incorporated in the work and use of plant and machinery belonging to the contractor. The certificate of the Engineer-in-Charge as to the value of work done shall be final and conclusive against the contractor provided always that action under this clause shall only be taken after giving notice in writing to the contractor. Provided also that if the expenses incurred by the department are less than the amount payable to the contractor at his agreement rates, the difference shall not be payable to the contractor.



Any excess expenditure incurred or to be incurred by Corporation in completing the part work/ part incomplete work of any item(s) or the excess loss of damages suffered or may be suffered by Corporation as aforesaid after allowing such credit shall without prejudice to another right or remedy available to Corporation in law or per as agreement be recovered from any money due to the contractor on any account, and if such money is insufficient, the contractor shall be called upon in writing and shall be liable to pay the same within 30 days.

If the contractor fails to pay the required sum within the aforesaid period of 30 days, the Engineer-in-Charge shall have the right to sell any or all of the contractors' unused materials, constructional plant, implements, temporary building at site etc. and adjust the proceeds of sale thereof towards the dues recoverable from the contractor under the contract and if thereafter there remains any balance outstanding, it shall be recovered in accordance with the provisions of the contract.

In the event of above course being adopted by the Engineer-in-Charge, the contractor shall have no claim to compensation for any loss sustained by him by reason of his having purchased or procured any materials or entered into any engagements or made any advance on any account or with a view to the execution of the work or the performance of the contract.

#### **CLAUSE 15**

**Suspension of Work** The contractor shall, on receipt of the order in writing of the Engineer-in-Charge, (whose decision shall be final and binding on the contractor) suspend the progress of the works or any part thereof for such time and in such manner as the Engineer-in-Charge may consider necessary so as not to cause any damage or injury to the work already done or endanger the safety thereof for any of the following reasons:

- (a) on account of any default on the part of the contractor or;
- (b) for proper execution of the works or part thereof for reasons other than the default of the contractor; or
- (c) for safety of the works or part thereof.

The contractor shall, during such suspension, properly protect and secure the works to the extent necessary and carry out the instructions given in that behalf by the Engineer in- Charge.

(ii) If the suspension is ordered for reasons (b) and (c) in sub-para (i) above:

- (a) the contractor shall be entitled to an extension of time equal to the period of every such suspension PLUS 25%, for completion of the item or group of items of work for which a separate period of completion is specified in the contract and of which the suspended work forms a part, and;

(b) If the total period of all such suspensions in respect of an item or group of items or work for which a separate period of completion is specified in the contract exceeds thirty days, the contractor shall, in addition, be entitled to such compensation as the Engineer-in- Charge may consider reasonable in respect of salaries and/or wages paid by the contractor to his employees and labour at site, remaining idle during the period of suspension, adding thereto 2% to cover indirect expenses of the contractor provided the contractor submits his claim supported by details to the Engineer-in-Charge within fifteen days of the expiry of the period of 30 days.

(iii) If the works or part thereof is suspended on the orders of the Engineer-in-Charge for more than three months at a time, except when suspension is ordered for reason (a) in subpara(i) above, the contractor may after receipt of such order serve a written notice on the Engineer-in-Charge requiring permission within fifteen days from receipt by the Engineer in-Charge of the said notice, to proceed with the work or part thereof in regard to which progress has been suspended and if such permission is not granted within that time, the contractor, if he intends to treat the suspension, where it affects only a part of the works as an omission of such part by or where it affects whole of the works, as an abandonment of the works by Corporation, shall within ten days of expiry of such period of 15 days give notice in writing of his intention to the Engineer-in-Charge. In the event of the contractor treating the suspension as an abandonment of the contract by Corporation, he shall have no claim to payment of any compensation on account of any profit or advantage which he might have derived from the execution of the work in full but which he could not derive in consequence of the abandonment. He shall, however, be entitled touch compensation, as the Engineer-in-Charge may consider reasonable, in respect of salaries and/or wages paid by him to his employees and labour at site, remaining idle in consequence adding to the total thereof 2% to cover indirect expenses of the contractor provided the contractor submits his claim supported by details to the Engineer-in-Charge within 30 days of the expiry of the period of 3 months.

#### **CLAUSE 15 A**

**Compensation in case of Delay of Supply of Material by Govt.** The contractor shall not be entitled to claim any compensation from Corporation for the loss suffered by him on account of delay by Corporation in the supply of materials in schedule 'Where such delay is covered by the difficulties relating to the supply of wagons, force majeure or any reasonable cause beyond the control of the Corporation.  
This clause 15 A will not be applicable for works where no material is stipulated.

## CLAUSE 16

**Action in case** All works under or in course of execution or executed in pursuance of the  
**Worknotdone** contract, shall at all times be open and accessible to the inspection and  
**as per** supervision of the Engineer-charge, his authorized subordinates in charge of  
**Specifications** the work and all the superior officers, officer of the Quality Assurance Unit of the Department or any organization engaged by the Department for Quality Assurance and of the Chief Technical Examiner's Office, and the contractor shall, at all times, during the usual working hours and at all other times at which reasonable notice of the visit of such officers has been given to the contractor, either himself be present to receive orders and instructions or have a responsible agent duly accredited in writing, present for that purpose. Orders given to the Contractor's agent shall be considered to have the same force as if they had been given to the contractor himself.

If it shall appear to the Engineer-in-charge or his authorized subordinates in charge of the worker to the Chief Engineer in charge of Quality Assurance or his subordinate officers or the officers of the organization engaged by the Department for Quality Assurance or to the Chief Technical Examiner or his subordinate officers, that any work has been executed with unsound, imperfect, or unskilful workmanship, or with materials or articles provided by him for the execution of the work which are unsound or of a quality inferior to that contracted or otherwise not in accordance with the contract, the contractor shall, on demand in writing which shall be made within twelve months (six months in the case of work costing Rs. 10 Lac and below except roadwork) of the completion of the work from the Engineer-in-Charge specifying the work, materials or articles complained of notwithstanding that the same may have been passed, certified and paid for forthwith rectify, or remove and reconstruct the work so specified in whole or in part, as the case may require or as the case may be, remove the materials or articles so specified and provide other proper and suitable materials or articles at his own charge and cost. In the event of the failing to do so within a period specified by the Engineer-in- Charge in his demand aforesaid, then the contractor shall be liable to pay compensation at the same rate as under clause 2 of the contract (for non-completion of the work in time) for this default.

In such case the Engineer-in-Charge may not accept the item of work at the rates applicable under the contract but may accept such items at reduced rates as the authority specified in schedule 'F' may consider reasonable during the preparation of on account bills or final bill if the item is so acceptable

without detriment to the safety and utility of the item and the structure or he may reject the work outright without any payment and/or get it and other connected and incidental items rectified, or removed and re-executed at the risk and cost of the contractor. Decision of the Engineer-in-Charge to be conveyed in writing in respect of the same will be final and binding on the contractor.

#### **CLAUSE 17**

**Contractor  
Liable  
for Damages,  
defects  
during  
defect  
liability  
period** If the contractor or his working people or servants shall break, deface, injure or destroy any part of building in which they may be working, or any building, road, road kerb, fence enclosure, water pipe, cables, drains, electric or telephone post or wires, trees, grass or grassland, or cultivated ground contiguous to the premises on which the work or any parties being executed, or if any damage shall happen to the work while in progress, from any cause whatever or if any defect, shrinkage or other faults appear in the work within twelve months (six months in the case of work costing Rs. Ten lacs and below except road work) after a certificate final or otherwise of its completion shall have been given by the Engineer in-Charge as aforesaid arising out of defect or improper materials or workmanship the contractor shall upon receipt of a notice in writing on that behalf make the same good at his own expense or in default the Engineer-in-Charge cause the same to be made good bother workmen and deduct the expense from any sums that may be due or at any time thereafter may become due to the contractor, or from his security deposit or the proceeds of sale thereof or of a sufficient portion thereof. The security deposit of the contractor shall not be refunded before the expiry of twelve months (six months in the case of work costings. Ten lacs and below except road work) after the issue of the certificate final or otherwise, of completion of work, or till the final bill has been prepared and passed whichever is later. Provided that in the case of road work, if in the opinion of the Engineer-in-Charge, half of the security deposit is sufficient, to meet all liabilities of the contractor under this contract, half of the security deposit will be refundable after six months and the remaining half after twelve months of the issue of the said certificate of completion or till the final bill has been prepared and passed whichever is later.

In case of Maintenance and Operation works of E&M services, the security deposit deducted from contractors shall be refunded within one month from the date of final payment or within one month from the date of completion of the maintenance contract whichever is earlier.

#### CLAUSE 18

**Contractor to Supply Tools & Plants etc.** The contractor shall provide at his own cost all materials (except such special materials, if any, as may in accordance with the contract be supplied from the Engineer-in-Charge's stores), machinery, tools & plants as specified in schedule F. In addition to this, appliances, implements, other plants, ladders, cordage, tackle, scaffolding and temporary works required for the proper execution of the work, whether original, altered or substituted and whether included in the specifications or other documents forming part of the contract or referred to in these conditions or not, or which may be necessary for the purpose of satisfying or complying with the requirements of the Engineer-in-Charge as to any matter as to which under these conditions he is entitled to be satisfied, or which he is entitled to require together with carriage therefore to and from the work. The contractor shall also supply without charge the requisite number of persons with the means and materials, necessary for the purpose of setting out works, and counting, weighing and assisting the measurement for examination at any time and from time to time of the work or materials. Failing his so doing, the same may be provided by the Engineer-in-Charge at the expense of the contractor and the expenses may be deducted, from any money due to the contractor, under this contract or otherwise and/or from his security deposit or the proceeds of sale thereof, or of sufficient portions thereof.

#### CLAUSE 18 A

**Recovery of Compensation paid to Workmen** In every case in which by virtue of the provisions sub-section (1) of Section 12, of the Workmen's Compensation Act, 1923, the Corporation is obliged to pay compensation to workman employed by the contractor, in execution of the works, Corporation will recover from the contractor, the amount of the compensation so paid; and, without prejudice to the rights of the Corporation under sub-section (2) of Section 12, of the said Act, the Corporation shall be at liberty to recover such amount or any part thereof by deducting it from the security deposit or from any sum due by the Corporation to the contractor whether under this contract or otherwise. The Corporation shall not be bound to contest any claim made against it under sub-section (1) of Section 12, of the said Act, except on the written request of the contractor and upon his giving to Corporation full security for all costs for which the Corporation might become liable in consequence of contesting such claim.

#### CLAUSE 18 B

**Ensuring Payment and Amenities to** In every case in which by virtue of the provisions of the Contract Labour (Regulation and Abolition) Act, 1970, and of the Contract Labour (Regulation and Abolition) Central Rules, 1971, The Corporation is obliged to pay any

**Workers if Contractor fails**

amounts of wages to a workman employed by the contractor in execution of the works, or to incur any expenditure in providing welfare and health amenities required to be provided under the above said Act and the rules under Clause 19H or under the C.P.W.D. Contractor's Labour Regulations, or under the Rules framed by Government from time to time for the protection of health and sanitary arrangements for workers employed by Central Warehousing Corporation's Contractors, the Corporation will recover from the contractor, the amount of wages so paid or the amount of expenditure so incurred; and without prejudice to the rights of the Corporation under sub-section(2) of Section 20, and sub-section (4) of Section 21, of the Contract Labour (Regulation and Abolition) Act, 1970, Corporation shall be at liberty to recover such amount or any part thereof by deducting it from the security depositor from any sum due by Corporation to the contractor whether under this contract or otherwise. Corporation shall not be bound to contest any claim made against it under sub-section (1) of Section 20, sub-section (4) of Section 21, of the said Act, except on the written request of the contractor and upon his giving to the Corporation full security for all costs for which Corporation might become liable in contesting such claim.

**CLAUSE 19**

**Labour Laws To be complied by the Contractor**

The contractor shall obtain a valid licence under the Contract Labour (R&A) Act, 1970, and the Contract Labour (Regulation and Abolition) Central Rules, 1971, before the commencement of the work, and continue to have a valid license until the completion of the work. **The contractor shall also comply with provisions of the Inter-State Migrant Workmen (Regulation of Employment and Conditions of Service) Act, 1979.** The contractor shall also abide by the provisions of the Child Labour (Prohibition and Regulation) Act, 1986.

The contractor shall also comply with the provisions of the building and other Construction Workers (Regulation of Employment & Conditions of Service) Act, 1996 and the building and other Construction Workers Welfare Cess Act, 1996. Any failure to fulfil these requirements shall attract the penal provisions of this contract arising out of the resultant non-execution of the work.

**CLAUSE 19A**

No labour below the age of fourteen years shall be employed on the work.

**CLAUSE 19 B**

**Payment of Wages**

Payment of wages:

(i) The contractor shall pay to labour employed by him either directly or through subcontractors, wages not less than fair wages as defined in the C.P.W.D. Contractor's Labour Regulations or as per the provisions of the Contract Labour (Regulation and Abolition) Act, 1970 and the contract Labour

(Regulation and Abolition) Central Rules, 1971, wherever applicable.

(ii) The contractor shall, notwithstanding the provisions of any contract to the contrary, cause to be paid fair wage to labour indirectly engaged on the work, including any labour engaged by his sub-contractors in connection with the said work, as if the labour had been immediately employed by him.

(iii) In respect of all labour directly or indirectly employed in the works for performance of the contractor's part of this contract, the contractor shall comply with or cause to be complied with the Central Public Works Department contractor's Labour Regulations made by Government from time to time in regard to payment of wages, wage period, deductions from wages recovery of wages not paid and deductions unauthorized made, maintenance of wage books or wage slips, publication of scale of wages and other terms of employment, inspection and submission of periodical returns and all other matters of the like nature as per the provisions of the Contract Labour (Regulation and Abolition) Act, 1970, and the Contract Labour (Regulation and Abolition) Central Rules, 1971, wherever applicable.

(iv) (a) The Engineer-in-Charge concerned shall have the right to deduct from the moneys due to the contractor any sum required or estimated to be required for making good the loss suffered by a worker or workers by reason of non-fulfilment of the conditions of the contract for the benefit of the workers, non-payment of wages or of deductions made from his or their wages which are not justified by their terms of the contract or non-observance of the Regulations.

(b) Under the provision of Minimum Wages (Central) Rules, 1950, the contractor is bound to allow to the labours directly or indirectly employed in the works one-day rest for 6 days' continuous work and pay wages at the same rate as for duty. In the event of default, the Engineer-in-Charge shall have the right to deduct the sum or sums not paid on account of wages for weekly holidays to any labours and pay the same to the persons entitled thereto from any money due to the contractor by the Engineer-in-Charge concerned.

In the case of Union Territory of Delhi, however, as the all-inclusive minimum daily wages fixed under Notification of the Delhi Administration No.F.12(162) MWO/DAB/43884-91, dated 31-12-1979 as amended from time to time are inclusive of wages for the weekly day of rest, the question of extra payment for weekly holiday would not arise.

(v) The contractor shall comply with the provisions of the Payment of Wages Act, 1936, Minimum Wages Act, 1948, Employees Liability Act, 1938, Workmen's Compensation Act, 1923, Industrial Disputes Act, 1947, Maternity

Benefits Act, 1961, and the Contractor's Labour (Regulation and Abolition) Act 1970, or the modifications thereof or any other laws relating thereto and the rules made thereunder from time to time.

(vi) The contractor shall indemnify and keep indemnified Corporation against payments to be made under and for the observance of the laws aforesaid and the C.P.W.D. Contractor's Labour Regulations without prejudice to his right to claim indemnity from his sub-contractors.

(vii) The laws aforesaid shall be deemed to be a part of this contract and any breach thereof shall be deemed to be a breach of this contract.

(viii) Whatever is the minimum wage for the time being, or if the wage payable is higher than such wage, such wage shall be paid by the contractor to the workmen directly without the intervention of Jamadar and that Jamadar shall not be entitled to deduct or recover any amount from the minimum wage payable to the workmen as and byway of commission or otherwise.

(ix) The contractor shall ensure that no amount by way of commission or otherwise is deducted or recovered by the Jamadar from the wage of workmen.

#### **CLAUSE 19C**

In respect of all labour directly or indirectly employed in the work for the performance of the contractor's part of this contract, the contractor shall at his own expense arrange for the safety provisions as per C.P.W.D. Safety Code framed from time to time and shall at his own expense provide for all facilities in connection therewith. In case the contractor fails to make arrangement and provide necessary facilities as aforesaid, he shall be liable to pay a penalty of Rs.200/- for each default and in addition, the Engineer-in- Charge shall be at liberty to make arrangement and provide facilities as aforesaid and recover the costs incurred in that behalf from the contractor.

#### **CLAUSE 19 D**

The contractor shall submit by the 4th and 19th of every month, to the Engineer-in-Charge, a true statement showing in respect of the second half of the preceding month and the first half of the current month respectively:-

- (1) the number of labourers employed by him on the work,
- (2) their working yours,
- (3) the wages paid to them,



- (4) the accidents that occurred during the said fortnight showing the circumstances under which they happened and the extent of damage and injury caused by them, and
- (5) the number of female workers who have been allowed maternity benefit according to Clause 19F and the amount paid to them.

Failing which the contractor shall be liable to pay to Corporation, a sum not exceeding Rs.200/- for each default or materially incorrect statement. The decision of the Engineer-in-Charge shall be final in deducting from any bill due to the contractor, the amount levied as fine and be binding on the contractor.

#### **CLAUSE 19 E**

In respect of all labour directly or indirectly employed in the works for the performance of the contractor's part of this contract, the contractor shall comply with or cause to be complied with all the rules framed by Corporation from time to time for the protection of health and sanitary arrangements for workers employed by the Central Public Works Department and its contractors.

#### **CLAUSE 19 F**

Leave and pay during leave shall be regulated as follows:-

1. Leave:

(i) in the case of delivery - maternity leave not exceeding 8 weeks, 4 weeks up to and including the day of delivery and 4 weeks following that day, in the case of miscarriage - up to 3 weeks from the date of miscarriage.

2. Pay:

(i) in the case of delivery - leave pay during maternity leave will be at the rate of the women's average daily earnings, calculated on total wages earned on the days when full time work was done during a period of three months immediately preceding the date on which she gives notice that she expects to be confined or at the rate of Rupee one only a day whichever is greater.

(ii) in the case of miscarriage - leave pay at the rate of average daily earning calculated on the total wages earned on the days when full time work was done during a period of three months immediately preceding the date of such miscarriage.

3. Conditions for the grant of Maternity Leave:

No maternity leave benefit shall be admissible to a woman unless she has been employed for a total period of not less than six months immediately preceding the date on which she proceeds on leave.

4. The contractor shall maintain a register of Maternity (Benefit) in the Prescribed Form as shown in appendix -I and II, and the same shall be kept at the place of work.

**CLAUSE 19 G**

In the event of the contractor(s) committing a default or breach of any of the provisions of the Central Public Works Department, Contractor's Labour Regulations and Model Rules for the protection of health and sanitary arrangements for the workers as amended from time to time or furnishing any information or submitting or filing any statement under the provisions of the above Regulations and' Rules which is materially incorrect, he/they shall, without prejudice to any other liability, pay to the Corporation a sum not exceeding Rs.200/- for every default, breach or furnishing, making, submitting, filing such materially incorrect statements and in the event of the contractor(s) defaulting continuously in this respect, the penalty may be enhanced to Rs.200/- per day for each day of default subject to a maximum of 5 per cent of the estimated cost of the work put to tender. The decision of the Engineer-in-Charge shall be final and binding on the parties.

Should it appear to the Engineer-in-Charge that the contractor(s) is/are not properly observing and complying with the provisions of the C.P.W.D. Contractor's Labour Regulations and Model Rules and the provisions of the Contract Labour (Regulation and Abolition) Act 1970, and the Contract Labour (R& A) Central Rules 1971, for the protection of health and sanitary arrangements for work-people employed by the contractor(s)(hereinafter referred as "the said Rules") the Engineer-in-Charge shall have power to give notice in writing to the contractor(s) requiring that the said Rules be complied with and the amenities prescribed therein be provided to the work-people within a reasonable time to be specified in the notice. If the contractor(s) shall fail within the period specified in the notice to comply with and/observe the said Rules and to provide the amenities to the work-people as aforesaid, the Engineer-in-Charge shall have the power to provide the amenities hereinbefore mentioned at the cost of the contractor(s). The contractor(s) shall erect, make and maintain at his/their own expense and to approved standards all necessary huts and sanitary arrangements required for his/their work-people on the site in connection with the execution of the works, and if the same shall not have been erected or constructed, according to approved standards, the Engineer-in-Charge shall have power to give notice in writing to the contractor(s) requiring that the said huts and sanitary arrangements be remodelled and/or reconstructed according to approved standards, and if the

contractor(s) shall fail to remodel or reconstruct such huts and sanitary arrangements according to approved standards within the period specified in the notice, the Engineer-in-Charge shall have the power to remodel or reconstruct such huts and sanitary arrangements according to approved standards at the cost of the contractor(s).

#### **CLAUSE 19 H**

The contractor(s) shall at his/their own cost provide his/their labour with a sufficient number of huts (hereinafter referred to as the camp) of the following specifications on a suitable plot of land to be approved by the Engineer-in-Charge.

(i) (a) The minimum height of each hut at the eaves level shall be 2.10m (7 ft.) and the floor area to be provided will be at the rate of 2.7 sq. (30 sq.ft.) for each member of the worker's family staying with the labourer.

(b) The contractor(s) shall in addition construct suitable cooking places having a minimum area of 1.80m x 1.50m (6'x5') adjacent to the hut for each family.

(c) The contractor(s) shall also construct temporary latrines and urinals for the use of the labourers each on the scale of not less than four per each one hundred of the total strength, separate latrines and urinals being provided for women.

(d) The contractor(s) shall construct sufficient number of bathing and washing places, one unit for every 25 persons residing in the camp. These bathing and washing places shall be suitably screened.

(ii) (a) All the huts shall have walls of sun-dried or burnt-bricks laid in mud mortar or other suitable local materials as may be approved by the Engineer-in-Charge. In case of sun-dried bricks, the walls should be plastered with mud gobri on both sides. The floor may be kutcha but plastered with mud gobri and shall be at least 15 cm (6") above the surrounding ground. The roofs shall be laid with thatch or any other materials as may be approved by the Engineer-in-Charge and the contractor shall ensure that throughout the period of their occupation, the roofs remain water-tight.

(b) The contractor(s) shall provide each hut with proper ventilation.

(c) All doors, windows, and ventilators shall be provided with suitable leaves for security purposes.

(d) There shall be kept an open space of at least 7.2m (8 yards) between the rows of huts which may be reduced to 6m (20 ft.) according to the availability of site with the approval of the Engineer-in-Charge. Back to back construction will be allowed.

(iii) **Water Supply** - The contractor(s) shall provide adequate supply of water for the use of labourers. The provisions shall not be less than two gallons of pure and wholesome water per head per day for drinking purposes and three gallons of clean water per head per day for bathing and washing purposes. Where piped water supply is available, supply shall be at stand posts and where the supply is from wells or river, tanks which may be of metal or masonry, shall be provided. The contractor(s) shall also at his/ their own cost make arrangements for laying pipe lines for water supply to his/ their labour camp from the existing mains wherever available, and shall pay all fees and charges therefore.

(iv) The site selected for the camp shall be high ground, removed from jungle.

(v) **Disposal of Excreta** - The contractor(s) shall make necessary arrangements for the disposals of excreta from the latrines by trenching or incineration which shall be according to the requirements laid down by the Local Health Authorities. If trenching or incinerations not allowed, the contractor(s) shall make arrangements for the removal of the excreta through the Municipal Committee/authority and inform it about the number of labourers employed so that arrangements may be made by such Committee/authority for the removal of the excreta. All charges on this account shall be borne by the contractor and paid direct by him to the Municipality/authority. The contractor shall provide one sweeper for every eight seats in case of dry system.

(vi) **Drainage** - The contractor(s) shall provide efficient arrangements for draining away sullage water so as to keep the camp neat and tidy.

(vii) The contractor(s) shall make necessary arrangements for keeping the camp area sufficiently lighted to avoid accidents to the workers.

(viii) **Sanitation** - The contractor(s) shall make arrangements for conservancy and sanitation in the labour camps according to the rules of the Local Public Health and Medical Authorities.

#### **CLAUSE 19 I**

The Engineer-in-Charge may require the contractor to dismiss or remove from

the site of the work any person or persons in the contractors' employ upon the work who may be incompetent or misconduct himself and the contractor shall forthwith comply with such requirements. In respect of maintenance/repair or renovation works etc. where the labour have an easy access to the individual houses, the contractor shall issue identity cards to the labourers, whether temporary or permanent and he shall be responsible for any untoward action on the part of such labour. AE/JE will display a list of contractors working in the colony/Blocks on the notice board in the colony and also at the service centre, to apprise the residents about the same.

**CLAUSE 19J**

It shall be the responsibility of the contractor to see that the building under construction is not occupied by anybody unauthorized during construction, and is handed over to the Engineer-in-Charge with vacant possession of complete building. If such building though completed is occupied illegally, then the Engineer-in-Charge shall have the option to refuse to accept the said building/buildings in that position. Any delay in acceptance on this account will be treated as the delay in completion and for such delay, a levy up to 5% of tendered value of work may be imposed by the Superintending Engineer whose decision shall be final both with regard to the justification and quantum and be binding on the contractor.

However, the Superintending Engineer, through a notice, may require the contractor to remove the illegal occupation any time on or before construction and delivery.

**CLAUSE 19K**

**Employment  
ofskilled/semi  
i  
Skilled  
workers**

The contractor shall, at all stages of work, deploy skilled/semi-skilled tradesmen who are qualified and possess certificate in particular trade from CPWD Training Institute/Industrial Training Institute/National Institute of Construction Management and Research (NICMAR)/National Academy of Construction, CIDC or any similar reputed and recognized Institute managed/certified by State/Central Government. The number of such qualified tradesmen shall not be less than 20% of total skilled/semi-skilled workers required in each trade at any stage of work. The contractor shall submit number of man days required in respect of each trade, its scheduling and the list of qualified tradesmen along with requisite certificate from recognized Institute to Engineer in charge for approval. Notwithstanding such approval, if the tradesmen are found to have inadequate skill to execute the work of respective trade, the contractor shall substitute such tradesmen within two days of written notice from Engineer-in- Charge. Failure on the part of

contractor to obtain approval of Engineer-in-Charge or failure to deploy qualified tradesmen will attract a compensation to be paid by contractor at the rate of Rs. 100 per such tradesman per day. Decision of Engineer in Charge as to whether particular tradesman possesses requisite skill and amount of compensation in case of default shall be final and binding.

Provided always, that the provisions of this clause, shall not be applicable for works with estimated cost put to tender being less than Rs. 5 crores.

#### **CLAUSE 19L**

**Contribution of EPF and ESI** The ESI and EPF contributions on the part of employer in respect of this contract shall be paid by the contractor. The ESI, EPF and other labour compliance will be sole responsibility of Contractor, CWC will not provide any thing over and above rate quoted by contractor. Contractor will provide the proof to CWC for submission of ESI & EPF to respective authorities along with bills and proof of final amount deposited to respective authorities for ESI & EPF along with final bill compulsorily. If the contractor fails to do so, CWC will deduct appropriate amount from contractor's bill/ Security deposit and pay to the respective authorities.

#### **CLAUSE 20**

**Minimum Wages Act to be Complied with** The contractor shall comply with all the provisions of the Minimum Wages Act, 1948, and Contract Labour (Regulation and Abolition) Act, 1970, amended from time to time and rules framed thereunder and other labour laws affecting contract labour that may be brought into force from time to time.

#### **CLAUSE 21**

**Work not to be sublet. Action in case of insolvency** The contract shall not be assigned or sublet without the written approval of the Engineer-in -Charge. And if the contractor shall assign or sublet his contract, or attempt so, or become insolvent or commence any insolvency proceedings or make any composition with his creditors or attempt to do so, or if any bribe, gratuity, gift, loan, perquisite, reward or advantage pecuniary or otherwise, shall either directly or indirectly, be given, promised or offered by the contractor, or any of his servants or agent to any public officer or person in the employee of The Corporation in any way relating to his office or employment, or if any such officer or person shall become in any way directly or indirectly interested in the contract, the Engineer in-Charge on behalf of the Corporation shall have power to adopt the course specified in Clause 3 hereof in the interest of The Corporation and in the event of such course being adopted, the consequences specified in the said Clause 3 shall ensue.

#### **CLAUSE 22**

All sums payable by way of compensation under any of these conditions shall be considered as reasonable compensation to be applied to the use of the Corporation without reference to the actual loss or damage sustained and whether or not any damage shall have been sustained.

#### **CLAUSE 23**

##### **Changes in firm's Constitution to be Intimated**

Where the contractor is a partnership firm, the previous approval in writing of the Engineer in-Charge shall be obtained before any change is made in the constitution of the firm. Where the contractor is an individual or a Hindu undivided family business concern, such approval as aforesaid shall likewise be obtained before the contractor enters into any partnership agreement where under the partnership firm would have the right to carry out the works hereby undertaken by the contractor. If previous approval as aforesaid is not obtained, the contract shall be deemed to have been assigned in contravention of Clause 21 hereof and the same action may be taken, and the same consequences shall ensue as provided in the said Clause 21.

#### **CLAUSE 24**

All works to be executed under the contract shall be executed under the direction and subject to the approval in all respects of the Engineer-in-Charge who shall be entitled to direct at what point or points and in what manner they are to be commenced, and from time to time carried on.

#### **CLAUSE 25**

##### **Settlement of Disputes & Arbitration**

Except where otherwise provided in the contract, all questions and disputes relating to the meaning of the specifications, design, drawings and instructions here-in before mentioned and as to the quality of workmanship or materials used on the work or as to any other question, claim, right, matter or thing whatsoever in any way arising out of or relating to the contract, designs, drawings, specifications, estimates, instructions, orders or these conditions or otherwise concerning the works or the execution or failure to execute the same whether arising during the progress of the work or after the cancellation, termination, completion or abandonment thereof shall be dealt with as mentioned hereinafter:

(i) If the contractor considers any work demanded of him to be outside the requirements of the contract, or disputes any drawings, record or decision given in writing by the Engineer-in-Charge or if the Engineer in Charge considers any act or decision of the contractor on any matter in connection

with or arising out of the contract or carrying out of the work, to be unacceptable and is disputed, such party shall promptly within 15 days of the arising of the disputes request the Chief Engineer or where there is no Chief Engineer, the Director who shall refer the disputes to Dispute Redressal Committee (DRC) within 15 days along with a list of disputes with amounts claimed if any in respect of each such dispute. The Dispute Redressal Committee (DRC) shall give the opposing party two weeks for a written response, and, give its decision within a period of 60 days extendable by 30 days by consent of both the parties from the receipt of reference from CE. The constitution of Dispute Redressal Committee (DRC) shall be as indicated in Schedule 'F'. Provided that no party shall be represented before the Dispute Redressal Committee by an advocate/legal counsel etc. If the Dispute Redressal Committee (DRC) fails to give its decision within the aforesaid period or any party is dissatisfied with the decision of Dispute Redressal Committee (DRC) or expiry of time limit given above, then either party may within a period of 30 days from the receipt of the decision of Dispute Redressal Committee (DRC), give notice to the Managing Director, CWC, New Delhi for appointment of arbitrator on prescribed proforma as per Appendix XV under intimation to the other party.

It is a term of contract that each party invoking arbitration must exhaust the aforesaid mechanism of settlement of claims/disputes prior to invoking arbitration.

**The Managing Director, CWC, New Delhi shall in such case appoint the sole arbitrator for adjudication of those disputes within 90 days from the date of receipt of request from the party.**

(ii) Disputes or difference shall be referred for adjudication through arbitration to a sole arbitrator where Tendered amount is Rs. 100 Crore or less. Where Tendered Value is more than Rs. 100 Crore, Tribunal shall consist of three Arbitrators as above. The requirements of the Arbitration and Conciliation Act, 1996 (26 of 1996) and any further statutory modifications or re-enactment thereof and the rules made there under and for the time being in force shall be applicable.

It is a term of this contract that the party invoking arbitration shall give a list of disputes with amounts claimed, if any, in respect of each such dispute along with the notice for appointment of arbitrator and giving reference to the decision of the DRC.

It is also a term of this contract that any member of the Arbitration Tribunal shall be a Graduate Engineer with experience in handling public works



engineering contracts at a level not lower than Chief Engineer. This shall be treated as a mandatory qualification to be appointed as arbitrator.

Parties, before or at the time of appointment of Arbitral Tribunal may agree in writing for fast track arbitration as per the Arbitration and Conciliation Act, 1996 (26 of 1996) as amended in 2015.

The arbitration shall be conducted in accordance with the provisions of the Arbitration and Conciliation Act- 1996 (26) of 1996/ The Jammu & Kashmir Arbitration and Conciliation Act 1997 (35 of 1997) (as the case may be) or any statutory modification or re-enactment thereof and the rules made thereunder and for the time being in force shall apply to the arbitration proceeding under this clause.

Subject to provision in the Arbitration and Conciliation Act, 1996 (26 of 1996) as amended in 2015 whereby the counter claims if any can be directly filed before the arbitrator without any requirement of reference by the appointing authority, the arbitrator shall adjudicate on only such disputes as are referred to him by the appointing authority and give separate award against each dispute and claim referred to him and in all cases where the total amount of the claims by any party exceeds Rs. 1,00,000/-, the arbitrator shall give reasons for the award.

It is also a term of the contract that if any fees are payable to the arbitrator, these shall be paid as per the Act.

**The place of arbitration shall be as mentioned in Schedule F. In case there is no mention of place of arbitration, the arbitrator shall determine the place of arbitration.**

#### **CLAUSE 26**

**Contractor to indemnify Govt. against Patent Rights**

The contractor shall fully indemnify and keep indemnified the Corporation against any action, claim or proceeding relating to infringement or use of any patent or design or any alleged patent or design rights and shall pay any royalties which may be payable in respect of any article or part thereof included in the contract. In the event of any claims made under or action brought against the Corporation in respect of any such matters as aforesaid, the contractor shall be immediately notified thereof and the contractor shall be at liberty, at his own expense, to settle any dispute or to conduct any litigation that may arise therefrom, provided that the contractor shall not be liable to indemnify the Corporation if the infringement of the patent or design or any alleged patent or design right is the direct result of an order passed by the Engineer-in-Charge in this behalf.

### CLAUSE 27

**Lumpsum Provisions in Tender**

When the estimate on which a tender is made includes lump sum in respect of parts of the work, the contractor shall be entitled to payment in respect of the items of work involved or the part of the work in question at the same rates as are payable under this contract for such items, or if the part of the work in question is not, in the opinion of the Engineer-in-Charge payable of measurement, the Engineer-in-Charge may at his discretion pay the lump-sum amount entered in the estimate, and the certificate in writing of the Engineer-in-Charge shall be final and conclusive against the contractor with regard to any sum or sums payable to him under the provisions of the clause.

### CLAUSE 28

**Action where no Specifications are Specified**

In the case of any class of work for which there is no such specifications as referred to in Clause 11, such work shall be carried out in accordance with the Bureau of Indian Standards Specifications. In case there are no such specifications in Bureau of Indian Standards, the work shall be carried out as per manufacturers' specifications, if not available then as per District Specifications. In case there are no such specifications as required above, the work shall be carried out in all respects in accordance with the instructions and requirements of the Engineer-in-Charge.

### CLAUSE 29

**Withholding and lien in respect of sum due from contractor**

(i) Whenever any claim or claims for payment of a sum of money arises out of or under the contract or against the contractor, the Engineer-in-Charge or the Corporation shall be entitled to withhold and also have a lien to retain such sum or sums in whole or in part from the security, if any deposited by the contractor and for the purpose aforesaid, the Engineer in-Charge or the Corporation shall be entitled to withhold the security deposit, if any, furnished as the case may be and also have a lien over the same pending finalisation or adjudication of any such claim. In the event of the security being insufficient to cover the claimed amount or amounts or if no security has been taken from the contractor, the Engineer-in-Charge or the Corporation shall be entitled to withhold and have a lien to retain to the extent of such claimed amount or amounts referred to above, from any sum or sums found payable or which may at any time thereafter become payable to the contractor under the same contract or any other contract with the Engineer-in-Charge or the Corporation or any contracting person through the Engineer in- Charge pending finalization of adjudication of any such claim.

It is an agreed term of the contract that the sum of money or moneys so withheld or retained under the lien referred to above by the Engineer-in-Charge or Corporation will be kept withheld or retained as such by the Engineer-in-Charge or Corporation till the claim arising out of or under the contract is determined by the arbitrator(if the contract is governed by the arbitration clause) by the competent court, as the case may be and that the contractor will have no claim for interest or damages whatsoever on any account in respect of such withholding or retention under the lien referred to above and duly notified as such to the contractor. For the purpose of this clause, where the contractor is a partnership firm or a limited company, the Engineer-in-Charge or the Corporation shall be entitled to withhold and also have a lien to retain towards such claimed amount or amounts in whole or in part from any sum found payable to any partner/limited company as the case may be, whether in his individual capacity or otherwise.

(ii) The Corporation shall have the right to cause an audit and technical examination of the works and the final bills of the contractor including all supporting vouchers, abstract, etc., to be made after payment of the final bill and if as a result of such audit and technical examination any sum is found to have been overpaid in respect of any work done by the contractor under the contract or any work claimed to have been done by him under the contract and found not to have been executed, the contractor shall be liable to refund the amount of over-payment and it shall be lawful for the Corporation to recover the same from him in the manner prescribed in sub-clause (i) of this clause or in any other manner legally permissible; and if it is found that the contractor was paid less than what was due to him under the contract in respect of any work executed by him under it, the amount of such under payment shall be duly paid by Corporation to the contractor, without any interest thereon whatsoever.

Provided that the Corporation shall not be entitled to recover any sum overpaid, nor the contractor shall be entitled to payment of any sum paid short where such payment has been agreed upon between the Superintending Engineer or Executive Engineer on the one hand and the contractor on the other under any term of the contract permitting payment for work after assessment by the Superintending Engineer or the Executive Engineer.

### **CLAUSE 29A**

**Lien in respect  
of claims in  
other Contracts**

Any sum of money due and payable to the contractor (including the security deposit returnable to him) under the contract may be withheld or retained by way of lien by the Engineer-in-Charge or the Corporation or any other contracting person or persons through Engineer-in-Charge against any claim of the Engineer-in-Charge or Corporation or such other person or persons in respect of payment of a sum of money arising out of or under any other contract made by the contractor with the Engineer- in-Charge or the Corporation or with such other person or persons.

It is an agreed term of the contract that the sum of money so withheld or retained under this clause by the Engineer-in-Charge or the Corporation will be kept withheld or retained as such by the Engineer-in-Charge or the Corporation or till his claim arising out of the same contract or any other contract is either mutually settled or determined by the arbitration clause or by the competent court, as the case may be and that the contractor shall have no claim for interest or damages whatsoever on this account or on any other ground in respect of any sum of money withheld or retained under this clause and duly notified as such to the contractor.

### **CLAUSE 30**

**Employment of  
coal mining or  
controlled area  
labour not  
permissible**

The contractor shall not employ coal mining or controlled area labour falling under any category whatsoever on or in connection with the work or recruit labour from area within a radius of 32 km (20 miles) of the controlled area. Subject as above the contractor shall employ imported labour only i.e., deposit imported labour or labour imported by contractors from area, from which import is permitted.

Where ceiling price for imported labour has been fixed by State or Regional Labour Committees not more than that ceiling price shall be paid to the labour by the contractor.

The contractor shall immediately remove any labourer who may be pointed out by the Engineer in- Charge as being a coal mining or controlled area labourer. Failure to do so shall render the contractor liable to pay to the Corporation a sum calculated at the rate of Rs.10/- per day per labourer. The certificate of the Engineer-in-Charge about the number of coal mining or controlled area labourer and the number of days for which they worked shall be final and binding up all parties to this contract.

It is declared and agreed between the parties that the aforesaid stipulation

in this clause is one in which the public are interested within the meaning of the exception in Section 74 of Indian Contract Act, 1872.

**Explanation:** - Controlled Area means the following areas:

Districts of Dhanbad, Hazaribagh, Jamtara - a Sub-Division under Santhal Pargana Commissioner, Districts of Bankura, Birbhum, Burdwan, District of Bilaspur.

Any other area which may be declared a Controlled Area by or with the approval of the Central Government.

### **CLAUSE 31**

#### **Unfiltered water Supply**

The contractor(s) shall make his/their own arrangements for water required for the work and nothing extra will be paid for the same. This will be subject to the following conditions.

(i) That the water used by the contractor(s) shall be fit for construction purposes to the satisfaction of the Engineer-in-Charge.

(ii) The Engineer-in-Charge shall make alternative arrangements for supply of water at the risk and cost of contractor(s) if the arrangements made by the contractor(s) for procurement of water are in the opinion of the Engineer-in-Charge, unsatisfactory.

### **CLAUSE 31 A**

#### **Departmental water supply, if available**

Water if available may be supplied to the contractor by the department subject to the following conditions:-

(i) The water charges @ 1 % shall be recovered on gross amount of the work done.

(ii) The contractor(s) shall make his/their own arrangement of water connection and laying of pipelines from existing main of source of supply.

(iii) The Department do not guarantee to maintain uninterrupted supply of water and it will be incumbent on the contractor(s) to make alternative arrangements for water at his/ their own cost in the event of any temporary break down in the Corporation water main so that the progress of his/their work is not held up for want of water. No claim of damage or refund of water charges will be entertained on account of such break down.

### **CLAUSE 32**

#### **Alternate water arrangements**

i) Where there is no piped water supply arrangement and the water is taken by the contractor from the wells or hand pump constructed by the

Corporation, no charge shall be recovered from the contractor on that account. The contractor shall, however, draw water at such hours of the day that it does not interfere with the normal use for which the hand pumps and wells are intended. He will also be responsible for all damage and abnormal repairs arising out of his use, the cost of which shall be recoverable from him. The Engineer-in-Charge shall be the final authority to determine the cost recoverable from the contractor on this account and his decision shall be binding on the contractor.

ii) The contractor shall be allowed to construct temporary wells in Corporation land for taking water for construction purposes only after he has got permission of the Engineer-in- Charge in writing. No charges shall be recovered from the contractor on this account, but the contractor shall be required to provide necessary safety arrangements to avoid any accidents or damage to adjacent buildings, roads and service lines. He shall be responsible for any accidents or damage caused due to construction and subsequent maintenance of the wells and shall restore the ground to its original condition after the wells are dismantled on completion of the work.

### **CLAUSE 33**

#### **Return of Surplus materials**

Notwithstanding anything contained to the contrary in this contract, where any materials for the execution of the contract are procured with the assistance of Corporation either by issue from Corporation stocks or purchase made under orders or permits or licences issued by Corporation, the contractor shall hold the said materials economically and solely for the purpose of the contract and not dispose of them without the written permission of the Corporation and return, if required by the Engineer-in-Charge, all surplus or unserviceable materials that may be left with him after the completion of the contract or at its termination for any reason whatsoever on being paid or credited such price as the Engineer-in-Charge shall determine having due regard to the condition of the materials. The price allowed to the contractor however shall not exceed the amount charged to him excluding the element of storage charges. The decision of the Engineer in- Charge shall be final and conclusive. In the event of breach of the aforesaid condition, the contractor shall in addition to throwing himself open to action for contravention of the terms of the licence or permit and/or for criminal breach of trust, be liable to Corporation for all moneys, advantages or profits resulting or which in the usual course would have resulted to him by reason of such breach.

### CLAUSE 34

#### **Hire of Plant & Machinery**

(i) The contractor shall arrange at his own expense all tools, plant, machinery and equipment (hereinafter referred to as T&P) required for execution of the work except for the Plant & Machinery listed in Schedule 'C' and stipulated for issue to the contractor. If the contractor requires any item of T&P on hire from the T&P available with the CWC over and above the T&P stipulated for issue, the Corporation will, if such item is available, hire it to the contractor at rates to be agreed upon between him and the Engineer-in-Charge. In such a case, all the conditions hereunder for issue of T&P shall also be applicable to such T&P as is agreed to be issued.

(ii) Plant and Machinery when supplied on hire charges shown in Schedule 'C' shall be made over and taken back at the departmental equipment yard/shed shown in Schedule 'C' and the contractor shall bear the cost of carriage from the place of issue to the site of work and back. The contractor shall be responsible to return the plant and machinery with condition in which it was handed over to him, and he shall be responsible for all damage caused to the said plant and machinery at the site of work or elsewhere in operation and otherwise during transit including damage to or loss of plant and for all losses due to his failure to return the same soon after the completion of the work for which it was issued. The Engineer-in-Charge shall be the sole judge to determine the liability of the contractor and its extent in this regard and his decision shall be final and binding on the contractor.

(iii) The plant and machinery as stipulated above will be issued as and when available and if required by the contractor. The contractor shall arrange his programme of work according to the availability of the plant and machinery and no claim, whatsoever, will be entertained from him for any delay in supply by the Department.

(iv) The hire charges shall be recovered at the prescribed rates from and inclusive of the date the plant and machinery made over up to and inclusive of the date of the return in good order even though the same may not have been working for any cause except major breakdown due to no fault of the contractor or faulty use requiring more than three working days continuously (excluding intervening holidays and Sundays) for bringing the plant in order. The contractor shall immediately intimate in writing to the Engineer-in-Charge when any plant or machinery gets out of order requiring major repairs as aforesaid. The Engineer-in-Charge shall record

the date and time of receipt of such intimation in the log sheet of the plant or machinery. Based on this if the breakdown before lunch period or major breakdown will be computed considering half a day's breakdown on the day of complaint. If the breakdown occurs in the post lunch period of major breakdown will be computed starting from the next working day. In case of any dispute under this clause, the decision of the Chief Engineer/ Superintending Engineer shall be final and binding on the contractor.

(v) The hire charges shown above are for each day of 8 hours (inclusive of the one-hour lunch break) or part thereof.

(vi) Hire charges will include service of operating staff as required and also supply of lubricating oil and stores for cleaning purposes. Power fuel of approved type, firewood, kerosene oil etc. for running the plant and machinery and also the full time chowkidar for guarding the plant and machinery against any loss or damage shall be arranged by the contractor who shall be fully responsible for the safeguard and security of plant and machinery. The contractor shall on or before the supply of plant and machinery sign an agreement indemnifying the Department against any loss or damage caused to the plant and machinery either during transit or at site of work.

(vii) Ordinarily, no plant and machinery shall work for more than 8 hours a day inclusive of one-hour lunch break. In case of an urgent work however, the Engineer-in-Charge may, at his discretion, allow the plant and machinery to be worked for more than normal period of 8 hours a day. In that case, the hourly hire charges for overtime to be borne by the contractor shall be 50% more than the normal proportionate hourly charges (1/8th of the daily charges) subject to a minimum of half day's normal charges on any particular day. For working out hire charges for over time, a period of half an hour and above will be charged as one hour and a period of less than half an hour will be ignored.

(viii) The contractor shall release the plant and machinery every seventh day for periodical servicing and/or wash out which may take about three to four hours or more. Hire charges for full day shall be recovered from the contractor for the day of servicing/ wash out irrespective of the period employed in servicing.

(ix) The plant and machinery once issued to the contractor shall not be returned by him on account of lack of arrangements of labour and materials, etc. on his part, the same will be returned only when they are



required for major repairs or when in the opinion of the Engineer-in-Charge, the work or a portion of work for which the same was issued is completed.

(x) Log Book for recording the hours of daily work for each of the plant and machinery supplied to the contractor will be maintained by the Department and will be countersigned by the contractor or his authorized agent daily. In case the contractor contests the correctness of the entries and/or fails to sign the Log Book, the decision of the Engineer in-Charge shall be final and binding on him. Hire charges will be calculated according to the entries in the Log Book and will be binding on the contractor. Recovery on account of hire charges for road rollers shall be made for the minimum number of days worked out on the assumption that a roller can consolidate per day and maximum quantity of materials or area surfacing as noted against each in the annexed statement (see attached annexure).

(xi) In the case of concrete mixers, the contractors shall arrange to get the hopper cleaned and the drum washed at the close of the work each day or each occasion.

(a) In case rollers for consolidation are employed by the contractor himself, log book off such rollers shall be maintained in the same manner as is done in case of departmental rollers, maximum quantity of any items to be consolidated for each roller-day shall also be same as in Annexure to Clause 34(x). For less use of rollers, recovery for the less roller days shall be made at the stipulated issue rate.

(xii) The contractor shall be responsible to return the plant and machinery in the condition in which it was handed over to him and he shall be responsible for all damage caused to the said plant and machinery at the site of work or elsewhere in operation or otherwise or during transit including damage to or loss of parts, and for all losses due to his failure to return the same soon after the completion of the work for which it was issued. The Engineer-in-Charge shall be the sole judge to determine the liability of the contractor and its extent in this regard and his decision shall be final and binding on the contractor.

(xiii) The contractor will be exempted from levy of any hire charges for the number of days he is called upon in writing by the Engineer-in-Charge to suspend execution of the work, provided Corporation's plant and machinery in question have, in fact, remained idle with the contractor

because of the suspension

(xiv) In the event of the contractor not requiring any item of plant and machinery issued by Corporation though not stipulated for issue in Schedule 'C' any time after taking delivery at the place of issue, he may return it after two days written notice or at any time without notice if he agrees to pay hire charges for two additional days without, in any way, affecting the right of the Engineer-in-Charge to use the said plant and machinery during the said period of two days as he likes including hiring out to a third party.

#### **CLAUSE 35**

**Condition relating to use of asphaltic materials**

(i) The contractor undertakes to make arrangement for the supervision of the work by the firm supplying the tar or bitumen used.

(ii) The contractor shall collect the total quantity of tar or bitumen required for the work as per standard formula, before the process of painting is started and shall hypothecate it to the Engineer-in-Charge. If any bitumen or tar remains unused on completion of the work on account of lesser use of materials in actual execution for reasons other than authorized changes of specifications and abandonment of portion of work, a corresponding deduction equivalent to the cost of unused materials as determined by the Engineer-in-Charge shall be made and the material return to the contractors. Although the materials are hypothecated to Corporation, the contractor undertakes the responsibility for their proper watch, safe custody and protection against all risks. The materials shall not be removed from site of work without the consent of the Engineer-in-Charge in writing.

(iii) The completion of the work and the portion of the security deposit relating to asphaltic work shall be refunded after the expiry of this period.

#### **CLAUSE 36**

**Employment of Technical Staff and employees**

Contractors Superintendence, Supervision, Technical Staff & Employees

(i) The contractor shall provide all necessary superintendence during execution of the work and all along thereafter as may be necessary for proper fulfilling of the obligations under the contract.

The contractor shall immediately after receiving letter of acceptance of the tender and before commencement of the work, intimate in writing to the

Engineer-in-Charge, the name(s), qualifications, experience, age, address(s) and other particulars along with certificates, of the principal technical representative to be in charge of the work and other technical representative(s) who will be supervising the work. Minimum requirement of such technical representative(s) and their qualifications and experience shall not be lower than specified in Schedule 'F'. The Engineer-in-Charge shall within 3 days of receipt of such communication intimate in writing his approval or otherwise of such a representative(s) to the contractor. Any such approval may at any time be withdrawn and in case of such withdrawal, the contractor shall appoint another such representative(s) according to the provisions of this clause. Decision of the tender accepting authority shall be final and binding on the contractor in this respect. Such a principal technical representative and other technical representative(s) shall be appointed by the contractor soon after receipt of the approval from Engineer-in-charge and shall be available at site before start of work.

All the provisions applicable to the principal technical representative under the Clause will also be applicable to other technical representative(s) The principal technical representative and other technical representative(s) shall be present at the site of work for supervision at all times when any construction activity is in progress and also present himself/themselves, as required, to the Engineer-in-Charge and/or his designated representative to take instructions. Instructions given to the principal technical representative or other technical representative(s) shall be deemed to have the same force as if these have been given to the contractor. The principal technical representative and other technical representative(s) shall be actually available at site fully during all stages of execution of work, during recording/checking/test checking of measurements of works and whenever so required by the Engineer-in-Charge and shall also note down instructions conveyed by the Engineer-in- Charge or his designated representative(s) in the site order book and shall affix his/their signature in token of noting down the instructions and in token of acceptance of measurements/ checked measurements/ test checked measurements. The representative(s) shall not look after any other work. Substitutes, duly approved by Engineer-in-Charge of the work in similar manner as aforesaid shall be provided in event of absence of any of the representative(s) by more than two days.

If the Engineer-in-Charge, whose decision in this respect is final and binding on the contractor, is convinced that no such technical representative(s) is/are effectively appointed or is/are effectively attending or fulfilling the provision of this clause, a recovery (non-refundable) shall be effected from

the contractor as specified in Schedule 'F' and the decision of the Engineer-In-Charge as recorded in the site order book and measurement recorded checked/test checked in Measurement Books shall be final and binding on the contractor. Further if the contractor fails to appoint suitable technical Principal technical representative and/or other technical representative(s) and if such appointed persons are not effectively present or are absent by more than two days without duly approved substitute or do not discharge their responsibilities satisfactorily, the Engineer-in-Charge shall have full powers to suspend the execution of the work until such date as suitable other technical representative(s) is/are appointed and the contractor shall be held responsible for the delay so caused to the work. The contractor shall submit a certificate of employment of the technical representative(s) (in the form of copy of Form-16 or CPF deduction issued to the Engineers employed by him) along with every on account bill final bill and shall produce evidence if at any time so required by the Engineer-in-Charge.

(ii) The contractor shall provide and employ on the site only such technical assistants as are skilled and experienced in their respective fields and such foremen and supervisory staff as are competent to give proper supervision to the work. The contractor shall provide and employ skilled, semiskilled and unskilled labour as is necessary for proper and timely execution of the work. The Engineer-in-Charge shall be at liberty to object to and require the contractor to remove from the works any person who in his opinion misconducts himself, or is incompetent or negligent in the performance of his duties or whose employment is otherwise considered by the Engineer-in-Charge to be undesirable. Such person shall not be employed again at works site without the written permission of the Engineer in- Charge and the persons so removed shall be replaced as soon as possible by competent substitutes.

#### **CLAUSE 37**

**Levy/Taxes payable by Contractor**

(i) GST, Building and other Construction Workers Welfare Cess or any other tax, levy or Cess in respect of input for or output by this contract shall be payable by the contractor. The Corporation shall not entertain any claim whatsoever in this respect except as provided under Clause 38.

(ii) The contractor shall deposit royalty and obtain necessary permit for supply of the red bajri, stone, kankar, etc. from local authorities.

If pursuant to or under any law, notification or order any royalty, cess or the

like becomes payable by the Corporation and does not any time become payable by the contractor to the State Government, Local authorities in respect of any material used by the contractor in the works, then in such a case, it shall be lawful to the Corporation and it will have the right and be entitled to recover the amount paid in the circumstances as aforesaid from dues of the contractor.

#### **CLAUSE 38**

**Conditions for reimbursement of levy/taxes if levied after receipt of tenders**

(i) All tendered rates shall be inclusive of any tax, levy or cess applicable on last stipulated date of receipt of tender including extension if any. No adjustment i.e. increase or decrease shall be made for any variation in the rate of GST, Building and Other Construction Workers Welfare Cess or any tax, levy or cess applicable on inputs.

However, effect of variation in rates of GST or Building and Other Construction Workers Welfare Cess or imposition or repeal of any other tax, levy or cess applicable on output of the works contract shall be adjusted on either side, increase or decrease.

Provided further that for Building and Other Construction Workers Welfare Cess or any tax (other than GST), levy or cess varied or imposed after the last date of receipt of tender including extension if any, any increase shall be reimbursed to the contractor only if the contractor necessarily and properly pays such increased amount of taxes/levies/cess.

Provided further that such increase including GST shall not be made in the extended period of contract for which the contractor alone is responsible for delay as determined by authority for extension of time under Clause 5 in Schedule F.

(ii) The contractor shall keep necessary books of accounts and other documents for the purpose of this condition as may be necessary and shall allow inspection of the same by a duly authorized representative of the Corporation and/or the Engineer-in-Charge and shall also furnish such other information/document as the Engineer-in-Charge may require from time to time.

(iii) The contractor shall, within a period of 30 days of the imposition of any such further tax or levy or cess, give a written notice thereof to the Engineer-in-charge that the same is given pursuant to this condition, together with all necessary information relating thereto.

#### **CLAUSE 39**

**Termination of Contract on**

Without prejudice to any of the rights or remedies under this contract, if the contractor dies, the **Chief Engineer/ Superintending Engineer** on behalf

**death of contractor** of the Corporation shall have the option of terminating the contract without compensation to the contractor.

#### **CLAUSE 40**

**If relative working in CWC then the contractor not allowed to tender** The contractor shall not be permitted to tender for works in the CWC responsible for award and execution of contracts in which his near relative is posted as Accounts Officer or as an officer in any capacity between the grades of the Chief Engineer and Assistant Engineer (both inclusive). He shall also intimate the names of persons who are working with him in any capacity or are subsequently employed by him and who are near relatives to any Officer in the Central Warehousing Corporation. or in the Ministry of Food, Consumer Affairs and Public Distribution, Government of India, New Delhi. **The contractor would also be debarred from tendering in the Corporation for five years for any breach of this condition.**

NOTE: By the term “near relatives” is meant wife, husband, parents and grandparents, children and grandchildren, brothers and sisters, uncles, aunts and cousins and their corresponding in-laws.

#### **CLAUSE 41**

**No Gazetted Engineer to work as Contractor within one year of retirement** No engineer of Group B and above or other Group B and above officers employed in engineering or administrative duties in Central Warehousing Corporation shall work as a contractor or employee of a contractor for a period of one year after his retirement from Corporation service without the previous permission of the Corporation of in writing. This contract is liable to be cancelled if either the contractor or any of his employees is found at any time to be such a person who had not obtained the permission of Central Warehousing Corporation as aforesaid, before submission of the tender or engagement in the contractor’s service, as the case may be.

#### **CLAUSE 42**

**Return of material & recovery for excess material issued.** (i) After completion of the work and also at any intermediate stage in the event of non-reconciliation of materials issued, consumed and in balance - (see Clause 10), theoretical quantity of materials issued by the Corporation for use in the work shall be calculated on the basis and method given hereunder: -

(a) Quantity of cement & bitumen shall be calculated on the basis of quantity of cement & bitumen required for different items of work as shown in the Schedule of Rates mentioned in Schedule ‘F’. In case any item is executed for which standard constants for the consumption of cement or

bitumen are not available in the above mentioned schedule/statement or cannot be derived from the same shall be calculated on the basis of standard formula to be laid down by the Engineer-in-Charge.

(b) Theoretical quantity of steel reinforcement or structural steel sections shall be taken as the quantity required as per design or as authorized by Engineer-in-Charge, including authorized lap pages, chairs etc. plus 3% wastage due to cutting into pieces, such theoretical quantity being determined and compared with the actual issues each diameter wise, section wise and category wise separately.

(c) Theoretical quantity of G.I. & C.I. or other pipes, conduits, wires and cables, pig lead and G.I./M.S. sheets shall be taken as quantity actually required and measured plus 5% for wastage due to cutting into pieces (except in the case of G.I./M.S. sheets it shall be 10%), such determination & comparison being made diameter wise & category wise.

(d) For any other material as per actual requirements.

(ii) Over the theoretical quantities of materials so computed a variation shall be allowed as specified in Schedule 'F'. The difference in the net quantities of material actually issued to the contractor and the theoretical quantities including such authorized variation, if not returned by the contractor or if not fully reconciled to the satisfaction of the Engineer-in-Charge within fifteen days of the issue of written notice by the Engineer-in-charge to this effect shall be recovered at the rates specified in Schedule 'F', without prejudice to the provision of the relevant conditions regarding return of materials governing the contract. Decision of Engineer-in-Charge in regard to theoretical quantities of materials, which should have been actually used as per the Annexure of the standard schedule of rates and recovery at rates specified in Schedule 'F', shall be final & binding on the contractor.

For non-scheduled items, the decision of the Superintending Engineer regarding theoretical quantities of materials which should have been actually used, shall be final and binding on the contractor.

(iii) The said action under this clause is without prejudice to the right of the Corporation to take action against the contractor under any other conditions of contract for not doing the work according to the prescribed specifications.

### CLAUSE 43

#### **Compensation during warlike situations**

The work (whether fully constructed or not) and all materials, machines, tools and plants, scaffolding, temporary buildings and other things connected therewith shall be at the risk of the contractor until the work has been delivered to the Engineer-in-Charge and a certificate from him to that effect obtained. In the event of the work or any materials properly brought to the site for incorporation in the work being damaged or destroyed in consequence of hostilities or warlike operation, the contractor shall when ordered (in writing) by the engineer-in-Charge to remove any debris from the site, collect and properly stack or remove in store all serviceable materials salvaged from the damaged work and shall be paid at the contract rates in accordance with the provision of this agreement for the work of clearing the site of debris, stacking or removal of serviceable material and for reconstruction of all works ordered by the Engineer-in-Charge, such payments being in addition to compensation up to the value of the work originally executed before being damaged or destroyed and not paid for. In case of works damaged or destroyed but not already measured and paid for, the compensation shall be assessed by the Engineer-in-Charge up to Rs. 5,000/- and by the Superintending Engineer concerned for a higher amount. The contractor shall be paid for the damages/destruction suffered and for restoring the material at the rate based on analysis of rates tendered for in accordance with the provision of the contract. The certificate of the Engineer-in-Charge regarding the quality and quantity of materials and the purpose for which they were collected shall be final and binding on all parties to this contract.

Provided always that no compensation shall be payable for any loss in consequence of hostilities or warlike operations (a) unless the contractor had taken all such precautions against air raid as are deemed necessary by the Engineer-in-Charge (b) for any material etc. not on the site of the work or for any tools, plant, machinery, scaffolding, temporary building and other things not intended for the work.

In the event of the contractor having to carry out reconstruction as aforesaid, he shall be allowed such extension of time for its completion as is considered reasonable by the Engineer-in-Charge.



**CLAUSE 44**

**Apprentices Act provisions to be complied with**

The contractor shall comply with the provisions of the Apprentices Act, 1961 and the rules and orders issued thereunder from time to time. If he fails to do so, his failure will be a breach of the contract and the Chief Engineer/ Superintending Engineer may, in his discretion, cancel the contract.

The contractor shall also be liable for any pecuniary liability arising on account of any violation by him of the provisions of the said Act.

**CLAUSE 45**

**Release of Security deposit after labour clearance**

Release of Security Deposit of the work shall not be refunded till the contractor produces a clearance deposit after labour certificate from the Labour Officer. As soon as the work is virtually complete the contractor shall apply for the clearance certificate to the Labour Officer under intimation to the Engineer-in-Charge. The Engineer-in-Charge, on receipt of the said communication, shall write to the Labour Officer to intimate if any complaint is pending against the contractor in respect of the work. If no complaint is pending, on record till after 3 months after completion of the work and/or no communication is received from the Labour Officer to this effect till six months after the date of completion, it will be deemed to have received the clearance certificate and the Security Deposit will be released if otherwise due.

### Annexure to clause 34 (x)

#### Showing quantities of materials for areas of surfacing to be considered for working out minimum period for which hire charges of road roller are to be recovered

Sl.No.	Material of surfacing	Quantity or areas
1	Consolidation of earth subgrade	1860 Sq.m.
2	Consolidation of stones soling 15 cm. to 22.5 cm thick	170 Cu.m.
3	Consolidation of brick soling 10 cm. to 20 cm. thick	230 Cu.m.
4	Consolidation of wearing coat of stone ballast 7.5 cm to 11.5 cm thick	30 Cu.m.
5	Consolidation of wearing coat of brick ballast 10 cm. thick	60 Cu.m.
6	Spreading and consolidation of red bajri 6 mm.	1860 Sq.m.
7	Painting one coat using stone aggregate 12.5 mm nominal size- (a)@ 1.65 m <sup>3</sup> per 100 m <sup>2</sup> and paving bitumen A-90 or S-90 @ 2.25 Kg per m <sup>2</sup> (OR) (b)@ 1.50 m <sup>3</sup> per 100 m <sup>2</sup> and bitumen emulsion or Road tar @ 2.25 Kg per m <sup>2</sup> :	930 Sq.m.
8	Painting two coats using-	
(a)	For first coat, stone aggregate 12.5 mm nominal size: (i) @ 1.50 m <sup>3</sup> per 100 m <sup>2</sup> with paving bitumen A-90 or S-90 @ 2 Kg per m <sup>2</sup> (OR) (ii) @1.35 m <sup>3</sup> per 100 m <sup>2</sup> with bitumen emulsion @ 2 Kg per m <sup>2</sup> (OR) (iii) @1.25 m <sup>3</sup> per 100 m <sup>2</sup> with roadtar @ 2.25 Kg per m <sup>2</sup> (OR)	:600 Sq.m.
(b)	For 2nd Coat, stone aggregate 10mm nominal size 0.9 Cu.m. per 100 Sq.m with- (i) 1kg of paving bitumen A-90 or S-90 or bitumen emulsion per Sq.m. (OR) (ii) 1.25 Kg. of road tar, per Sq.m.	:600 Sq.m.
9	Re-painting with stone aggregate 10 mm nominal size 0.9 Cu.m. per 100 Sq.m. with- (a) 1Kg. of paving bitumen, A-90 or S-90 per Sq.m. (OR) (b) 1.25 kg of Bitumen emulsion per Sq.m.	:1670 Sq.m.
10	2 cm premix carpet surfacing using 2.4 m <sup>3</sup> of stone aggregate 10 mm nominal size per 100 m <sup>2</sup> and binder including tack coat, the binder being hot cut back bitumen or bitumen emulsion specified quantities.	: 930 Sq.m.
11	2.5 cm. premix carpet surfacing using 3 m <sup>3</sup> of stone aggregate 10 mm nominal size per 100 m <sup>2</sup> and binder including tack coat, the binder being hot cut back Bitumen or bitumen emulsion in specified quantities.	:930 S q.m.
12	4 cm thick bitumen concrete surfacing using stone aggregate 3.8 Cu.m. (60% 20 mm nominal size and 40% 12.5 mm nominal size) per 100 m <sup>2</sup> and coarse sand 1.9 Cu.m. per 100 m <sup>2</sup> and hot cut back bitumen over a tack coat of hot cut back bitumen.	460 Sq.m
13	5 cm thick bitumen concrete surfacing using stone aggregate 4.8 Cu.m. (60% 25 mm nominal size and 40% 20 mm nominal size) per 100 m <sup>2</sup> and	

- coarse sand 2.4 Cu.m per 100 Sq.m. and hot cut back bitumen over a tack coat of hot cut back bitumen 370 Sq.m.
- 14 6cm thick bitumen concrete surfacing using stone aggregate 5.8 Cu.m. (60 % 40 mm. nominal size and 40% 25mm nominal size) per 100 Sq.m. and coarse sand 2.9 Cu.m. per 100 Sq.m. and hot cut back bitumen over a tack coat of hot cut back bitumen. 280 Sq.m
- 15 7.5cm thick bitumen concrete surfacing using stone aggregate 7.3 Cu.m. (60% 50mm nominal size and 40% 40 mm nominal size) per 100 Sq.m. and coarse sand 3.65 Cu.m. per 100 Sq.m. and hot cut back bitumen over a tack coat of hot cut back bitumen. 230 Sq.m.
- 16 2.5 cm bitumastic sheet using stone aggregate 1.65 Cu.m. (60% 12.5 mm nominal size, 40%10 mm nominal size) per 100 Sq.m. and coarse sand 1.65 Cu.m. per 100 Sq.m. and hot cut back bitumen over a tack coat of hot cut back bitumen. 750 Sq.m.
- 17 4cm bitumastic sheet, using stone aggregate 2.6 Cu.m. (60%12.5mm nominal size 40%10 mm nominal size) per 100 Sq.m., coarse sand 2.5 Cu.m. per 100 Sq.m. and hot cut back bitumen over a tack coat of hot bitumen. : 560 Sq.m.
- 18 Laying full grouted surface using stone aggregate 40 mm nominal size 6.10 Cum per 100 Sq.m. with binder, binding with 20mm to 12.5 mm nominal size stone grit. 1.83 Cu.m. per 100 Sq.m. and seal coat of binder and stone grit 10mm nominal size, 1.07Cu.m. per 100 Sq.m., the binder being hot bitumen or tar as specified. :460 Sq.m.
- 19 Laying full grouted surface using stone aggregate 50 mm nominal size 9.14 Cu.m. per 100 sq.m. grouting with binder, with stone grit 20 mm to to 12.5 mm nominal size, 1.83 Cu.m. per 100 Sq.m. and seal coat of binder and stone grit 10mm nominal size, 1.07 Cu.m./100Sq.m. the binder being hot bitumen or tar. : 370 Sq.m.
- 20 4cm. thick premix macadam surfacing using stone aggregate 25mm nominal size 4.57 Cu.m. per 100 Sq.m and hot bitumen binding with stone aggregate 12.5 mm nominal size 1.52 Cu.m. per 100 Sq.m. and seal coat of hot bitumen and stone aggregate 10mm nominal size. 1.07 Cu.m. per 100 Sq.m. : 560 Sq.m.
- 21 5cm thick premix macadam surfacing with stone aggregate 25 mm nominal size, 6.10 Cu.m. per 100 Sq.m and hot bitumen binding with stone aggregate 12.5 mm nominal size 1.52 Cu.m. per 100 Sq.m. and seal coat of hot bitumen and stone aggregate 10mm nominal size 1.07 Cu.m. per 100 Sq.m. :460 Sq.m.

## SAFETY CODE

1. Suitable scaffolds should be provided for workmen for all works that cannot safely be done from the ground, or from solid construction except such short period work as can be done safely from ladders. When a ladder is used, an extra mazdoor shall be engaged for holding the ladder and if the ladder is used for carrying materials as well suitable footholds and hand-hold shall be provided on the ladder and the ladder shall be given an inclination not steeper than  $\frac{1}{4}$  to  $1\frac{1}{4}$  horizontal and 1 vertical.)
2. Scaffolding of staging more than 3.6 m (12ft.) above the ground or floor, swung or suspended from an overhead support or erected with stationary support shall have a guard rail properly attached or bolted, braced and otherwise secured at least 90 cm. (3ft.) high above the floor or platform of such scaffolding or staging and extending along the entire length of the outside and ends thereof with only such opening as may be necessary for the delivery of materials. Such scaffolding or staging shall be so fastened as to prevent it from swaying from the building or structure.
3. Working platforms, gangways and stairways should be so constructed that they should not sag unduly or unequally, and if the height of the platform or the gangway or the stairway is more than 3.6 m (12ft.) above ground level or floor level, they should be closely boarded, should have adequate width and should be suitably fastened as described in (2) above.
4. Every opening in the floor of a building or in a working platform shall be provided with suitable means to prevent the fall of person or materials by providing suitable fencing or railing whose minimum height shall be 90 cm. (3ft.)
5. Safe means of access shall be provided to all working platforms and other working places. Every ladder shall be securely fixed. No portable single ladder shall be over 9m. (30ft.) in length while the width between side rails in rung ladder shall in no case be less than 29 cm. (11½") for ladder up to and including 3 m. (10 ft.) in length. For longer ladders, this width should be increased at least  $\frac{1}{4}$ " for each additional 30 cm. (1 foot) of length. Uniform step spacing of not more than 30 cm shall be kept. Adequate precautions shall be taken to prevent danger from electrical equipment. No materials on any of the sites or work shall be so stacked or placed as to cause danger or inconvenience to any person or the public. The contractor shall provide all necessary fencing and lights to protect the public from accident and shall be bound to bear the expenses of defence of every suit, action or other proceedings at law that may be brought by any person for injury sustained owing to neglect of the above precautions and to pay any damages and cost which may be awarded in any such suit; action or proceedings to any such person or which may, with the consent of the contractor, be paid to compensate any claim by any such person.
6. (a) Excavation and Trenching - All trenches 1.2 m. (4ft.) or more in depth, shall at all times be supplied with at least one ladder for each 30 m. (100 ft.) in length or fraction thereof, Ladder shall extend from bottom of the trench to at least 90 cm. (3ft.) above the surface of the ground. The side of the trenches which are 1.5 m. (5ft.) or more in depth shall be stepped back to give suitable slope or securely held by timber bracing, so as to avoid the danger of sides collapsing. The excavated materials shall not be placed within 1.5 m. (5ft.) of the edges of the trench or half of

the depth of the trench whichever is more. Cutting shall be done from top to bottom. Under no circumstances, undermining or undercutting shall be done.

(b) Safety Measures for digging bore holes: -

- (i) If the bore well is successful, it should be safely capped to avoid caving and collapse of the bore well. The failed and the abandoned ones should be completely refilled to avoid caving and collapse;
- (ii) During drilling, sign boards should be erected near the site with the address of the drilling contractor and the Engineer in-charge of the work;
- (iii) Suitable fencing should be erected around the well during the drilling and after the installation of the rig on the point of drilling, flags shall be put 50m around the point of drilling to avoid entry of people;
- (iv) After drilling the borewell, a cement platform (0.50m x 0.50m x 1.20m) 0.60m above ground level and 0.60m below ground level should be constructed around the well casing;
- (v) After the completion of the borewell, the contractor should cap the bore well properly by welding steel plate, cover the bore well with the drilled wet soil and fix thorny shrubs over the soil. This should be done even while repairing the pump;
- (vi) After the borewell is drilled the entire site should be brought to the ground level.

7. Demolition - Before any demolition work is commenced and also during the progress of the work,

- (i) All roads and open areas adjacent to the work site shall either be closed or suitably protected.
- (ii) No electric cable or apparatus which is liable to be a source of danger or a cable or apparatus used by the operator shall remain electrically charged.
- (iii) All practical steps shall be taken to prevent danger to persons employed from risk of fire or explosion or flooding. No floor, roof or other part of the building shall be so overloaded with debris or materials as to render it unsafe.

8. All necessary personal safety equipment as considered adequate by the Engineer-in-Charge should be kept available for the use of the person employed on the site and maintained in a condition suitable for immediate use, and the contractor should take adequate steps to ensure proper use of equipment by those concerned: - The following safety equipment shall invariably be provided.

- (i) Workers employed on mixing asphaltic materials, cement and lime mortars shall be provided with protective footwear and protective goggles.
- (ii) Those engaged in white washing and mixing or stacking of cement bags or any material which is injurious to the eyes, shall be provided with protective goggles.
- (iii) Those engaged in welding works shall be provided with welder's protective eye shields.
- (iv) Stone breaker shall be provided with protective goggles and protective clothing and seated at sufficiently safe intervals.
- (v) When workers are employed in sewers and manholes, which are in active use, the contractors shall ensure that the manhole covers are opened and ventilated at least for an hour

before the workers are allowed to get into the manholes, and the manholes so opened shall be cordoned off with suitable railing and provided with warning signals or boards to prevent accident to the public. In addition, the contractor shall ensure that the following safety measure are adhered to: -

- (a) Entry for workers into the line shall not be allowed except under supervision of the JE or any other higher officer.
- (b) At least 5 to 6 manholes upstream and downstream should be kept open for at least 2 to 3 hours before any man is allowed to enter into the manhole for working inside.
- (c) Before entry, presence of Toxic gases should be tested by inserting wet lead acetate paper which changes colour in the presence of such gases and gives indication of their presence.
- (d) Presence of Oxygen should be verified by lowering a detector lamp into the manhole. In case, no Oxygen is found inside the sewer line, workers should be sent only with Oxygen kit.
- (e) Safety belt with rope should be provided to the workers. While working inside the manholes, such rope should be handled by two men standing outside to enable him to be pulled out during emergency.
- (f) The area should be barricaded or cordoned off by suitable means to avoid mishaps of any kind. Proper warning signs should be displayed for the safety of the public whenever cleaning works are undertaken during night or day.
- (g) No smoking or open flames shall be allowed near the blocked manhole being cleaned.
- (h) The malba obtained on account of cleaning of blocked manholes and sewer lines should be immediately removed to avoid accidents on account of slippery nature of the malba.
- (i) Workers should not be allowed to work inside the manhole continuously. He should be given rest intermittently. The Engineer-in-Charge may decide the time up to which a worker may be allowed to work continuously inside the manhole.
- (j) Gas masks with Oxygen Cylinder should be kept at site for use in emergency.
- (k) Air-blowers should be used for flow of fresh air through the manholes. Whenever called for, portable air blowers are recommended for ventilating the manholes. The Motors for these shall be vapour proof and of totally enclosed type. Non sparking gas engines also could be used but they should be placed at least 2 metres away from the opening and on the leeward side protected from wind so that they will not be a source of friction on any inflammable gas that might be present.
- (l) The workers engaged for cleaning the manholes/sewers should be properly trained before allowing to work in the manhole.
- (m) The workers shall be provided with Gumboots or non-sparking shoes bump helmets and gloves non sparking tools safety lights and gas masks and portable air blowers (when necessary). They must be supplied with barrier cream for anointing the limbs before working inside the sewer lines.
- (n) Workmen descending a manhole shall try each ladder stop or rung carefully before putting his full weight on it to guard against insecure fastening due to corrosion of the rung fixed to manhole well.

- (o) If a man has received a physical injury, he should be brought out of the sewer immediately and adequate medical aid should be provided to him.
  - (p) The extent to which these precautions are to be taken depend on individual situation but the decision of the Engineer-in-Charge regarding the steps to be taken in this regard in an individual case will be final.
  - (vi) The Contractor shall not employ men and women below the age of 18 years on the work of painting with products containing lead in any form. Wherever men above the age of 18 are employed on the work of lead painting, the following precaution should be taken: -
    - (a) No paint containing lead or lead products shall be used except in the form of paste or readymade paint.
    - (b) Suitable face masks should be supplied for use by the workers when paint is applied in the form of spray or a surface having lead paint is dry rubbed and scrapped.
    - (c) Overalls shall be supplied by the contractors to the workmen and adequate facilities shall be provided to enable the working painters to wash during and on the cessation of work.
9. An additional clause (viii)(i) of Central Public Works Department Safety Code (iv) the Contractor shall not employ women and men below the age of 18 on the work of painting with product containing lead in any form, wherever men above the age of 18 are employed on the work of lead painting, the following principles must be observed for such use:
- (i) White lead, sulphate of lead or product containing these pigment, shall not be used in painting operation except in the form of pastes or paint ready for use.
  - (ii) Measures shall be taken, wherever required in order to prevent danger arising from the application of a paint in the form of spray.
  - (iii) Measures shall be taken, wherever practicable, to prevent danger arising out of from dust caused by dry rubbing down and scraping.
  - (iv) Adequate facilities shall be provided to enable working painters to wash during and on cessation of work.
  - (v) Overall shall be worn by working painters during the whole of working period.
  - (vi) Suitable arrangement shall be made to prevent clothing put off during working hours being spoiled by painting materials.
  - (vii) Cases of lead poisoning and suspected lead poisoning shall be notified and shall be subsequently verified by medical man appointed by competent authority of Central Warehousing Corporation.
  - (viii) The Central Warehousing Corporation may require, when necessary medical examination of workers.
  - (ix) Instructions with regard to special hygienic precautions to be taken in the painting trade shall be distributed to working painters.
10. When the work is done near any place where there is risk of drowning, all necessary equipment's should be provided and kept ready for use and all necessary steps taken for prompt rescue of any person in danger and adequate provision, should be made for prompt first aid treatment of all injuries likely to be obtained during the course of the work.

11. Use of hoisting machines and tackle including their attachments, anchorage and supports shall conform to the following standards or conditions: -
- (i) (a) These shall be of good mechanical construction, sound materials and adequate strength and free from patent defects and shall be kept repaired and in good working order.
  - (b) Every rope used in hoisting or lowering materials or as a means of suspension shall be of durable quality and adequate strength, and free from patent defects.
  - (ii) Every crane driver or hoisting appliance operator, shall be properly qualified and no person under the age of 21 years should be in charge of any hoisting machine including any scaffolding winch or give signals to operator.
  - (iii) In case of every hoisting machine and of every chain ring hook, shackle swivel and pulley block used in hoisting or as means of suspension, the safe working load shall be ascertained by adequate means. Every hoisting machine and all gear referred to above shall be plainly marked with the safe working load. In case of a hoisting machine having a variable safe working load each safe working load and the condition under which it is applicable shall be clearly indicated. No part of any machine or any gear referred to above in this paragraph shall be loaded beyond the safe working load except for the purpose of testing.
  - (iv) In case of departmental machines, the safe working load shall be notified by the Electrical Engineer in- Charge. As regards contractor's machines the contractors shall notify the safe working load of the machine to the Engineer-in-Charge whenever he brings any machinery to site of work and get it verified by the Electrical Engineer concerned.
12. Motors, gearing, transmission, electric wiring and other dangerous parts of hoisting appliances should be provided with efficient safeguards. Hoisting appliances should be provided with such means as will reduce to the minimum the risk of accidental descent of the load. Adequate precautions should be taken to reduce to the minimum the risk of any part of a suspended load becoming accidentally displaced. When workers are employed on electrical installations which are already energized, insulating mats, wearing apparel, such as gloves, sleeves and boots as may be necessary should be provided. The worker should not wear any rings, watches and carry keys or other materials which are good conductors of electricity.
13. All scaffolds, ladders and other safety devices mentioned or described herein shall be maintained in safe condition and no scaffold, ladder or equipment shall be altered or removed while it is in use. Adequate washing facilities should be provided at or near places of work.
14. These safety provisions should be brought to the notice of all concerned by display on a notice board at a prominent place at work spot. The person responsible for compliance of the safety code shall be named therein by the contractor.
15. To ensure effective enforcement of the rules and regulations relating to safety precautions the arrangements made by the contractor shall be open to inspection by the Labour Officer or Engineer-in-Charge of the department or their representatives.
16. Notwithstanding the above clauses from (1) to (15), there is nothing in these to exempt the contractor from the operations of any other Act or Rule in force in the Republic of India.



**SECTION – VI**  
**(DIRECTIVES OF HON'BLE NATIONAL GREEN TRIBUNAL)**

---

## **Directives of Hon'ble National Green Tribunal**

1. The contractor shall not store/dump construction material or debris on metalled road. **(new works)**
2. The contractor shall get prior approval from Engineer-in-charge for the area where the construction material or debris can be stored beyond the metalled road. This area shall not cause any obstruction to the free flow of traffic/inconvenience to the pedestrians. It should be ensured by the contractor that no accidents occur on account of such permissible storage. **(new works)**
3. The contractor shall take appropriate protection measures like raising wind breakers of appropriate height on all side of the plot/area using CGI sheets or plastic and/or other similar material to ensure that no construction material dust fly outside the plot area. **(new works)**
4. The contractor shall ensure that all the trucks or vehicles of any kind which are used for construction purposes/or are carrying construction material like cement, sand and other allied material are fully covered. The contractor shall take every necessary precautions that the vehicles are properly cleaned and dust free to ensure that enroute their destination, the dust, sand or any other particles are not released in air/contaminate air.
5. The contractor shall provide mask to every worker working on the construction site and involved in loading, unloading and carriage of construction material and construction debris to prevent inhalation of dust particles.
6. The contractor shall provide all medical help, investigation and treatment to the workers involved in the construction of building and carry of construction material and debris relatable to dust emission.
7. The contractor shall ensure that C&D waste is transported to the C&D waste site only and due record shall be maintained by the contractor.
8. The contractor shall compulsory use of wet jet in grinding and stone cutting.
9. The contractor shall comply all the preventive and protective environmental steps as stated in the MoEF guidelines,2010.
10. The contractor shall carry out on-Road-Inspection for black smoke generating machinery. The contractor shall use cleaner fuel.
11. The contractor shall ensure that all DG sets comply emission norms notified by MoEF.
12. The contractor shall use vehicles having pollution under control certificate. The emissions can be reduced by a large extent by reducing the speed of a vehicle to 20Kmph. Speed bumps shall be used to ensure speed reduction. In case where speed reduction cannot effectively reduce fugitive dust, the contractor shall divert traffic to nearby paved areas.
13. The contractor shall ensure that the construction material is covered by tarpaulin. The contractor shall take all other precaution to ensure that no dust particles are permitted to pollute air quality as a result of such storage.
14. The paving of the path for plying of vehicles carrying construction material is more permanent solution to dust control and suitable for longer duration projects. The NIT approving authority shall carry out cost benefit ratio analysis of the same. **(new works)**

## **Section-VII**

### **(MODEL RULES FOR THE PROTECTION OF HEALTH AND SANITARY ARRANGEMENTS FOR WORKERS)**

## **Model Rules for the Protection of Health and Sanitary Arrangements for Workers Employed by Central Warehousing Corporation or its Contractors**

### **1. APPLICATION**

These rules shall apply to all buildings and construction works in charge of Central Warehousing Corporation in which twenty or more workers are ordinarily employed or are proposed to be employed in any day during the period during which the contract work is in progress.

### **2. DEFINITION**

Work place means a place where twenty or more workers are ordinarily employed in connection with construction work on any day during the period during which the contract work is in progress.

### **3. FIRST-AID FACILITIES**

(i) At every work place, there shall be provided and maintained, so as to be easily accessible during working hours, first-aid boxes at the rate of not less than one box for 150 contract labour or part thereof ordinarily employed.

(ii) The first-aid box shall be distinctly marked with a red cross on white back ground and shall contain the following equipment: -

(a) For work places in which the number of contract labour employed does not exceed 50-

Each first-aid box shall contain the following equipments: -

1. 6 small sterilised dressings.
2. 3 medium size sterilised dressings.
3. 3 large size sterilised dressings.
4. 3 large sterilised burn dressings.
5. 1 (30 ml.) bottle containing a two per cent alcoholic solution of iodine.
6. 1 (30 ml.) bottle containing Sal volatile having the dose and mode of administration indicated on the label.
7. 1 snakebite lancet.
8. 1 (30 gms.) bottle of potassium permanganate crystals.
9. 1 pair scissors.
10. 1 copy of the first-aid leaflet issued by the Director General, Factory Advice Service and Labour Institutes, Government of India.
11. 1 bottle containing 100 tablets (each of 5 gms.) of aspirin.
12. Ointment for burns.
13. A bottle of suitable surgical antiseptic solution.

(b) For work places in which the number of contract labour exceed 50.

Each first-aid box shall contain the following equipments.

1. 12 small sterilised dressings.
2. 6 medium size sterilised dressings.
3. 6 large size sterilised dressings.
4. 6 large size sterilised burn dressings.

5. 6 (15 gms.) packets sterilised cotton wool.
6. 1 (60 ml.) bottle containing a two per cent alcoholic solution iodine.
7. 1 (60 ml.) bottle containing Sal volatile having the dose and mode of administration indicated on the label.
8. 1 roll of adhesive plaster.
9. 1 snake bite lancet.
10. 1 (30 gms.) bottle of potassium permanganate crystals.
11. 1 pair scissors.
12. 1 copy of the first-aid leaflet issued by the Director General Factory Advice Service and Labour Institutes /Government of India.
13. A bottle containing 100 tablets (each of 5 gms.) of aspirin.
14. Ointment for burns.
15. A bottle of suitable surgical antiseptic solution.

(iii) Adequate arrangements shall be made for immediate recoument of the equipment when necessary.

(iv) Nothing except the prescribed contents shall be kept in the First-aid box.

(v) The first-aid box shall be kept in charge of a responsible person who shall always be readily available during the working hours of the work place.

(vi) A person in charge of the First-aid box shall be a person trained in First-aid treatment in the work places where the number of contract labour employed is 150 or more.

(vii) In work places where the number of contract labour employed is 500 or more and hospital facilities are not available within easy distance from the works. First-aid posts shall be established and run by a trained compounder. The compounder shall be on duty and shall be available at all hours when the workers are at work.

(viii) Where work places are situated in places which are not towns or cities, a suitable motor transport shall be kept readily available to carry injured person or person suddenly taken ill to the nearest hospital.

#### **4. DRINKING WATER**

(i) In every work place, there shall be provided and maintained at suitable places, easily accessible to labour, a sufficient supply of cold water fit for drinking.

(ii) Where drinking water is obtained from an Intermittent public water supply, each work place shall be provided with storage where such drinking water shall be stored.

(iii) Every water supply or storage shall be at a distance of not less than 50 feet from any latrine drain or other source of pollution. Where water has to be drawn from an existing well which is within such proximity of latrine, drain or any other source of pollution, the well shall be properly chlorinated before water is drawn from it for drinking. All such wells shall be entirely closed in and be provided with a trap door which shall be dust and waterproof.

(iv) A reliable pump shall be fitted to each covered well, the trap door shall be kept locked and opened only for cleaning or inspection which shall be done at least once a month.

## 5. WASHING FACILITIES

- (i) In every work place adequate and suitable facilities for washing shall be provided and maintained for the use of contract labour employed therein.
- (ii) Separate and adequate cleaning facilities shall be provided for the use of male and female workers.
- (iii) Such facilities shall be conveniently accessible and shall be kept in clean and hygienic condition.

## 6. LATRINES AND URINALS

- (i) Latrines shall be provided in every work place on the following scale namely: -
  - (a) Where females are employed, there shall be at least one latrine for every 25 females.
  - (b) Where males are employed, there shall be at least one latrine for every 25 males. Provided that, where the number of males or females exceeds 100, it shall be sufficient if there is one latrine for 25 males or females as the case may be up to the first 100, and one for every 50 thereafter.
- (ii) Every latrine shall be under cover and so partitioned off as to secure privacy, and shall have a proper door and fastenings.
- (iii) Construction of latrines: The inside walls shall be constructed of masonry or some suitable heat-resisting non-absorbent materials and shall be cement washed inside and outside at least once a year, Latrines shall not be of a standard lower than borehole system.
- (iv) (a) Where workers of both sexes are employed, there shall be displayed outside each block of latrine and urinal, a notice in the language understood by the majority of the workers "For Men only" or "For Women Only" as the case may be.
  - (b) The notice shall also bear the figure of a man or of a woman, as the case may be.
- (v) There shall be at least one urinal for male workers up to 50 and one for female workers up to fifty employed at a time, provided that where the number of male or female workmen, as the case may be, exceeds 500 it shall be sufficient if there is one urinal for every 50 males or females up to the first 500 and one for every 100 or part thereafter.
- (vi) (a) The latrines and urinals shall be adequately lighted and shall be maintained in a clean and sanitary condition at all times.
  - (b) Latrines and urinals other than those connected with a flush sewage system shall comply with the requirements of the Public Health Authorities.
- (vii) Water shall be provided by means of tap or otherwise so as to be conveniently accessible in or near the latrines and urinals.
- (viii) Disposal of excreta: - Unless otherwise arranged for by the local sanitary authority, arrangements for proper disposal of excreta by incineration at the work place shall be made by means of a suitable incinerator. Alternately excreta may be disposed of by putting a layer of night soil at the bottom of a pucca tank prepared for the purpose and covering it with a 15 cm. layer of waste or refuse and then covering it with a layer of earth for a fortnight (when it will turn to manure).
- (ix) The contractor shall at his own expense, carry out all instructions issued to him by the Engineer-in-Charge to effect proper disposal of night soil and other conservancy work in

respect of the contractor's workmen or employees on the site. The contractor shall be responsible for payment of any charges which may be levied by Municipal or Cantonment Authority for execution of such on his behalf.

## **7. PROVISION OF SHELTER DURING REST**

At every place there shall be provided, free of cost, four suitable sheds, two for meals and the other two for rest separately for the use of men and women labour. The height of each shelter shall not be less than 3 metres (10 ft.) from the floor level to the lowest part of the roof. These shall be kept clean and the space provided shall be on the basis of 0.6 sq.m. (6 sft) per head.

Provided that the Engineer-in-Charge may permit subject to his satisfaction, a portion of the building under construction or other alternative accommodation to be used for the purpose.

## **8. CRECHES**

- (i) At every work place, at which 20 or more women worker are ordinarily employed, there shall be provided two rooms of reasonable dimensions for the use of their children under the age of six years. One room shall be used as a play room for the children and the other as their bedroom. The rooms shall be constructed with specifications as per clause 19H (ii) a, b& c.
- (ii) The rooms shall be provided with suitable and sufficient openings for light and ventilation. There shall be adequate provision of sweepers to keep the places clean.
- (iii) The contractor shall supply adequate number of toys and games in the play room and sufficient number of cots and beddings in the bed room.
- (iv) The contractor shall provide one Ayaa to look after the children in the creche when the number of women workers does not exceed 50 and two when the number of women workers exceed 50.
- (v) The use of the rooms earmarked as creches shall be restricted to children, their attendants and mothers of the children.

## **9. CANTEENS**

- (i) In every work place where the work regarding the employment of contract labour is likely to continue for six months and where in contract labour numbering one hundred or more are ordinarily employed, an adequate canteen shall be provided by the contractor for the use of such contract labour.
- (ii) The canteen shall be maintained by the contractor in an efficient manner.
- (iii) The canteen shall consist of at least a dining hall, kitchen, storeroom, pantry and washing places separately for workers and utensils.
- (iv) The canteen shall be sufficiently lighted at all times when any person has access to it.
- (v) The floor shall be made of smooth and impervious materials and inside walls shall be lime washed or colour washed at least once in each year. Provided that the inside walls of the kitchen shall be lime-washed every four months.
- (vi) The premises of the canteen shall be maintained in a clean and sanitary condition.

- (vii) Waste water shall be carried away in suitable covered drains and shall not be allowed to accumulate so as to cause a nuisance.
- (viii) Suitable arrangements shall be made for the collection and disposal of garbage.
- (ix) The dining hall shall accommodate at a time 30 per cent of the contract labour working at a time.
- (x) The floor area of the dining hall, excluding the area occupied by the service counter and any furniture except tables and chairs shall not be less than one square metre (10 sft) per diner to be accommodated as prescribed in sub-Rule 9.
- (xi) (a) A portion of the dining hall and service counter shall be partitioned off and reserved for women workers in proportion to their number.  
(b) Washing places for women shall be separate and screened to secure privacy.
- (xii) Sufficient tables stools, chair or benches shall be available for the number of diners to be accommodated as prescribed in sub-Rule 9.
- (xiii) (a) 1. There shall be provided and maintained sufficient utensils crockery, furniture and any other equipments necessary for the efficient running of the canteen.  
2. The furniture utensils and other equipment shall be maintained in a clean and hygienic condition.  
(b) 1. Suitable clean clothes for the employees serving in the canteen shall be provided and maintained.  
2. A service counter, if provided, shall have top of smooth and impervious material.  
3. Suitable facilities including an adequate supply of hot water shall be provided for the cleaning of utensils and equipments.
- (xiv) The food stuffs and other items to be served in the canteen shall be in conformity with the normal habits of the contract labour.
- (xv) The charges for food stuffs, beverages and any other items served in the canteen shall be based on 'No profit, no loss' and shall be conspicuously displayed in the canteen.
- (xvi) In arriving at the price of foodstuffs, and other article served in the canteen, the following items shall not be taken into consideration as expenditure namely: -
  - (a) The rent of land and building.
  - (b) The depreciation and maintenance charges for the building and equipments provided for the canteen.
  - (b) The cost of purchase, repairs and replacement of equipments including furniture crockery, cutlery and utensils.
  - (d) The water charges and other charges incurred for lighting and ventilation.
  - (e) The interest and amounts spent on the provision and maintenance of equipments provided for the canteen.
- (xvii) The accounts pertaining to the canteen shall be audited once every 12 months by registered accountants and auditors.



**10. ANTI-MALARIAL PRECAUTIONS**

The contractor shall at his own expense, conform to all anti-malarial instructions given to him by the Engineer-in-Charge including the filling up of any borrow pits which may have been dug by him.

- 11.** The above rules shall be incorporated in the contracts and in notices inviting tenders and shall form an integral part of the contracts.

**12. AMENDMENTS**

Government may, from time to time, add to or amend these rules and issue directions - it may consider necessary for the purpose of removing any difficulty which may arise in the administration thereof.

**Section-VIII**  
**(C.P.W.D. Contractor's Labour Regulations)**

**C.P.W.D. Contractor's Labour Regulations-**  
**THESE REGULATIONS SHALL *MUTATIS-MUTANDIS* APPLY TO THE WORK OF THE**  
**CENTRAL WAREHOUSING CORPORATION**

**1. SHORT TITLE**

These regulations may be called the C.P.W.D./PWD (DA) Contractors Labour Regulations.

**2. DEFINITIONS**

i) **Workman** means any person employed by C.P.W.D./PWD (DA) or its contractor directly or indirectly through a subcontractor with or without the knowledge of the Central Public Works Department/PWD (DA) to do any skilled, semiskilled or unskilled manual, supervisory, technical or clerical work for hire or reward, whether the terms of employment are expressed or implied but does not include any person: -

a) Who is employed mainly in a managerial or administrative capacity: or

b) Who, being employed in a supervisory capacity draws wages exceeding five hundred rupees per mensem or exercises either by the nature of the duties attached to the office or by reason of powers vested in him, functions mainly of managerial nature: or

c) Who is an out worker, that is to say, person to whom any article or materials are given out by or on behalf of the principal employers to be made up cleaned, washed, altered, ornamental finished, repaired adopted or otherwise processed for sale for the purpose of the trade or business of the principal employers and the process is to be carried out either in the home of the out worker or in some other premises, not being premises under the control and management of the principal employer.

No person below the age of 14 years shall be employed to act as a workman.

ii) **Fair Wages** means wages whether for time or piece work fixed and notified under the provisions of the Minimum Wages Act from time to time.

iii) **Contractors** shall include every person who undertakes to produce a given result other than a mere supply of goods or articles of manufacture through contract labour or who supplies contract labour for any work and includes a subcontractor.

iv) **Wages** shall have the same meaning as defined in the Payment of Wages Act.

3. i) Normally working hours of an adult employee should not exceed 9 hours a day. The working day shall be so arranged that inclusive of interval for rest, if any, it shall not spread over more than 12 hours on any day.

ii) When an adult worker is made to work for more than 9 hours on any day or for more than 48 hours in any week, he shall be paid over time for the extra hours put in by him at double the ordinary rate of wages.

iii) a) Every worker shall be given a weekly holiday normally on a Sunday, in accordance with the provisions of the Minimum Wages (Central) Rules 1960 from time to time irrespective as amended of whether such worker is governed by the Minimum Wages Act or not.

b) Where the minimum wages prescribed by the Government under the Minimum Wages Act are not inclusive of the wages for the weekly day of rest, the worker shall be entitled to rest day wages at the rate applicable to the next preceding day, provided he has worked under the same contractor for a continuous period of not less than 6 days.

c) Where a contractor is permitted by the Engineer-in-Charge to allow a worker to work on a normal weekly holiday, he shall grant a substituted holiday to him for the whole day on one of the five days immediately before or after the normal weekly holiday and pay wages to such worker for the work performed on the normal weekly holiday at overtime rate.

#### **4. DISPLAY OF NOTICE REGARDING WAGES ETC.**

The contractor shall before he commences his work on contract, display and correctly maintain and continue to display and correctly maintain in a clear and legible condition in conspicuous places on the work, notices in English and in the local Indian languages spoken by the majority of the workers giving the minimum rates of wages fixed under Minimum Wages Act, the actual wages being paid, the hours of work for which such wage are earned, wages periods, dates of payments of wages and other relevant information as per Appendix 'III'.

#### **5. PAYMENT OF WAGES**

i) The contractor shall fix wage periods in respect of which wages shall be payable.

ii) No wage period shall exceed one month.

iii) The wages of every person employed as contract labour in an establishment or by a contractor where less than one thousand such persons are employed shall be paid before the expiry of seventh day and in other cases before the expiry of tenth day after the last day of the wage period in respect of which the wages are payable.

iv) Where the employment of any worker is terminated by or on behalf of the contractor the wages earned by him shall be paid before the expiry of the second working day from the date on which his employment is terminated.

v) All payment of wages shall be made on a working day at the work premises and during the time and on a date notified in advance and in case the work is completed before the expiry of the wage period, final payment shall be made within 48 hours of the last working day.

vi) Wages due to every worker shall be paid to him direct **by contractor through bank or ECS or online transfer to his Bank account.**

- vii) All wages shall be paid **through Bank or ECS or online transfer**
- viii) Wages shall be paid without any deductions of any kind except those specified by the Central Government by general or special order in this behalf or permissible under the Payment of Wages Act 1956.
- ix) A notice showing the wages period and the place and time of disbursement of wages shall be displayed at the place of work and a copy sent by the contractor to the Engineer-in-Charge under acknowledgment.
- x) It shall be the duty of the contractor to ensure the disbursement of wages through bank account of labour.
- xi) The contractor shall obtain from the Junior Engineer or any other authorised representative of the Engineer-in-Charge as the case may be, a certificate under his signature at the end of the entries in the "Register of Wages" or the "Wage-cum-Muster Roll" as the case may be in the following form: -  
 "Certified that the amount shown in column No .....has been paid to the workman concerned **through bank account of labour** on ..... at ....."

## 6. FINES AND DEDUCTIONS WHICH MAY BE MADE FROM WAGES

- (i) The wages of a worker shall be paid to him without any deduction of any kind except the following: -
  - (a) Fines
  - (b) Deductions for absence from duty i.e. from the place or the places where by the terms of his employment he is required to work. The amount of deduction shall be in proportion the period for which he was absent.
  - (c) Deduction for damage to or loss of goods expressly entrusted to the employed person for custody, or for loss of money or any other deduction which he is required to account, where such damage or loss is directly attributable to his neglect or default.
  - (d) Deduction for recovery of advances or for adjustment of overpayment of wages, advances granted shall be entered in a register.
  - (e) Any other deduction which the Central Government may from time to time allow.
- (ii) No fines should be imposed on any worker save in respect of such acts and omissions on his part as have been approved of by the Chief Labour Commissioner.  
**Note:** - An approved list of Acts and Omissions for which fines can be imposed is enclosed at Appendix-X
- (iii) No fine shall be imposed on a worker and no deduction for damage or loss shall be made from his wages until the worker has been given an opportunity of showing cause against such fines or deductions.

(iv) The total amount of fine which may be imposed in any one wage period on a worker shall not exceed an amount equal to three paise in a rupee of the total wages, payable to him in respect of that wage period.

(v) No fine imposed on any worker shall be recovered from him by instalment, or after the expiry of sixty days from the date on which it was imposed.

(vi) Every fine shall be deemed to have been imposed on the day of the act or omission in respect of which it was imposed.

## 7. LABOUR RECORDS

(i) The contractor shall maintain a **Register of persons employed** on work on contract in Form XIII of the CL (R&A) Central Rules 1971 (Appendix IV)

(ii) The contractor shall maintain a **Muster Roll** register in respect of all workmen employed by him on the work under Contract in Form XVI of the CL (R&A) Rules 1971 (Appendix V).

(iii) The contractor shall maintain a **Wage Register** in respect of all workmen employed by him on the work under contract in Form XVII of the CL (R&A) Rules 1971 (Appendix VI).

(iv) **Register of accident** - The contractor shall maintain a register of accidents in such form as maybe convenient at the work place but the same shall include the following particulars:

- a) Full particulars of the labourers who met with accident.
- b) Rate of Wages.
- c) Sex
- d) Age
- e) Nature of accident and cause of accident.
- f) Time and date of accident.
- g) Date and time when admitted in Hospital,
- h) Date of discharge from the Hospital.
- i) Period of treatment and result of treatment.
- j) Percentage of loss of earning capacity and disability as assessed by Medical Officer.
- k) Claim required to be paid under Workmen's Compensation Act.
- l) Date of payment of compensation.
- m) Amount paid with details of the person to whom the same was paid.
- n) Authority by whom the compensation was assessed.
- o) Remarks

(v) The contractor shall maintain a **Register of Fines** in the Form XII of the CL (R&A) Rules 1971 (Appendix-XI)

The contractor shall display in a good condition and in a conspicuous place of work the approved list of acts and omissions for which fines can be imposed (Appendix-X)

(vi) The contractor shall maintain a **Register of deductions for damage or loss** in Form XX of the CL (R&A) Rules 1971 (Appendix-XII)

(vii) The contractor shall maintain a **Register of Advances** in Form XXIII of the CL (R&A) Rules 1971 (Appendix-XIII)

(viii) The contractor shall maintain a **Register of Overtime** in Form XXIII of the CL (R&A) Rules 1971 (Appendix-XIV)

#### **8. ATTENDANCE CARD-CUM-WAGE SLIP**

- i) The contractor shall issue an **Attendance card-cum-wage slip** to each workman employed by him in the specimen form at (Appendix-VII)
  - ii) The card shall be valid for each wage period.
  - iii) The contractor shall mark the attendance of each workman on the card twice each day, once at the commencement of the day and again after the rest interval, before he actually starts work.
  - iv) The card shall remain in possession of the worker during the wage period under reference.
  - v) The contractor shall complete the wage slip portion on the reverse of the card at least a day prior to the disbursement of wages in respect of the wage period under reference.
  - vi) The contractor shall obtain the signature or thumb impression of the worker on the wage slip at the time of disbursement of wages and retain the card with himself.

#### **9. EMPLOYMENT CARD**

The contractor shall issue an **Employment Card** in Form XIV of the CL (R&A) Central Rules 1971 to each worker within three days of the employment of the worker (Appendix-VIII).

#### **10. SERVICE CERTIFICATE**

On termination of employment for any reason whatsoever the contractor shall issue to the workman whose services have been terminated, a **Service certificate** in Form XV of the CL (R&A) Central Rules 1971 (Appendix-IX)

#### **11. PRESERVATION OF LABOUR RECORDS**

All records required to be maintained under Regulations Nos. 6 & 7 shall be preserved in original for a period of three years from the date of last entries made in them and shall be made available for inspection by the Engineer-in-Charge or Labour Officer or any other officers authorised by the Ministry of Urban Development in this behalf.

## **12. POWER OF LABOUR OFFICER TO MAKE INVESTIGATIONS OR ENQUIRY**

The Labour Officer or any person authorised by Corporation on their behalf shall have power to make enquires with a view to ascertaining and enforcing due and proper observance of Fair Wage Clauses and the Provisions of these Regulations. He shall investigate into any complaint regarding the default made by the contractor or subcontractor in regard to such provision.

## **13. REPORT OF LABOUR OFFICER**

The Labour Officer or other persons authorised as aforesaid shall submit a report of result of his investigation or enquiry to the Engineer-in-Charge indicating the extent, if any, to which the default has been committed with a note that necessary deductions from the contractor's bill be made and the wages and other dues be paid to the labourers concerned. In case an appeal is made by the contractor under Clause 13 of these regulations, actual payment to labourers will be made by the Engineer-in-Charge after the Chief Engineer/ Superintending Engineer has given his decision on such appeal.

i) The Engineer-in-Charge shall arrange payments to the labour concerned within 45 days from the receipt of the report from the Labour Officer or the Chief Engineer/ Superintending Engineer as the case may be.

## **14. APPEAL AGAINST THE DECISION OF LABOUR OFFICER**

Any person aggrieved by the decision and recommendations of the Labour Officer or other person so authorised may appeal against such decision to the Chief Engineer/ Superintending Engineer concerned within 30 days from the date of decision, forwarding simultaneously a copy of his appeal to the Engineer-in-Charge but subject to such appeal, the decision of the officer shall be final and binding upon the contractor.

## **15. PROHIBITION REGARDING REPRESENTATION THROUGH LAWYER**

- i) A workman shall be entitled to be represented in any investigation or enquiry under these regulations by: -
- a) An officer of a registered trade union of which he is a member.
  - b) An officer of a federation of trade unions to which the trade union referred to in clause (a) is affiliated.
  - c) Where the employer is not a member of any registered trade union, by an officer of a registered trade union, connected with the industry in which the worker is employed or by any other workman employed in the industry in which the worker is employed.
- ii) An employer shall be entitled to be represented in any investigation or enquiry under these regulations by: -
- a) An officer of an association of employers of which he is a member.
  - b) An officer of a federation of associations of employers to which association referred to in clause (a) is affiliated.



- c) Where the employers are not a member of any association of employers, by an officer of association of employer connected with the industry in which the employer is engaged or by any other employer, engaged in the industry in which the employer is engaged.
- iii) No party shall be entitled to be represented by a legal practitioner in any investigation or enquiry under these regulations.

#### **16. INSPECTION OF BOOKS AND SLIPS**

The contractor shall allow inspection of all the prescribed labour records to any of his workers or to his agent at a convenient time and place after due notice is received or to the Labour Officer or any other person, authorised by the Central Government on his behalf.

#### **17. SUBMISSIONS OF RETURNS**

The contractor shall submit periodical returns as may be specified from time to time.

#### **18. AMENDMENTS**

The Central Government may from time to time add to or amend the regulations and on any question as to the application/Interpretation or effect of those regulations the decision of the Superintending Engineer concerned shall be final.

**APPENDIX - I**

REGISTER OF MATERNITY BENEFITS [Clause 19F]

Name and Address of the contractor(s) \_\_\_\_\_  
 \_\_\_\_\_

Name and Location of the work \_\_\_\_\_  
 \_\_\_\_\_

Name of the employee	Father's/Husband's Name	Nature of employment	Period of actual appointment	Date on which notice of confinement given
1	2	3	4	5

Date on which maternity leave commenced and ended

Date of miscarriage	Delivery/	In case of delivery		In case of miscarriage	
		Commenced	Ended	Commenced	Ended
6	7	8	9	10	10

Leave pay paid to the employee

<u>In case of delivery</u>		<u>In case of miscarriage</u>		Remarks
Rate of leave pay	Amount paid	Rate of leave pay	Amount paid	
11	12	13	14	15

**SPECIMEN FORM OF THE REGISTER, REGARDING  
MATERNITY BENEFIT ADMISSIBLE TO THE CONTRACTOR'S LABOUR  
IN CENTRAL WAREHOUSING CORPORATION WORKS.**

Name and address of the contractor.....

Name and location of the work.....

1. Name of the woman and her husband's name
2. Designation.
3. Date of appointment.
4. Date with months and years in which she is employed.
5. Date of discharge/dismissal, if any.
6. Date of production of certificates in respect of pregnancy.
7. Date on which the woman informs about the expected delivery.
8. Date of delivery/miscarriage/death
9. Date of production of certificate in respect of delivery/miscarriage.
10. Date with the amount of maternity/death benefit paid in advance of expected delivery.
11. Date with amount of subsequent payment of maternity benefit.
12. Name of the person nominated by the woman to receive the payment of the maternity benefit after her death.
13. If the woman dies, the date of her death, the name of the person to whom maternity benefit amount was paid, the month thereof and the date of payment.
14. Signature of the contractor authenticating entries in the register.
15. Remarks column for the use of Inspecting Officer.

**Labour Board**

Name of work.....  
 Name of Contractor.....  
 Address of Contractor.....  
 Name and address of Corporate Office.....  
 Name of Labour Enforcement Officer.....  
 Address of Labour Enforcement Officer.....

Sl.No.	Category	Minimum wage fixed	Actual wage paid	Number present	Remarks

Weekly holiday.....  
 Wage period.....  
 Date of payment of wages.....  
 Working hours.....  
 Rest interval.....

**APPENDIX 'IV'**

**FORM XIII**  
[See rule 75]

**Register of Workman Employed by Contractor**

Name & Address of Contractor \_\_\_\_\_

Name & Address of establishment under which contract is carried on \_\_\_\_\_

Nature & location of work \_\_\_\_\_

Name & Address of Principal Employer \_\_\_\_\_

Sl. No.	Name & Surname of workman	Age & Sex	Father's/ Husband's name	Nature of employment/ designation	Permanent home Address of the workman (Village and Tehsil, Taluk and District)	Local address	Date of commencement of employment	Signature or thumb impression of the workman	Date of termination of employment	Reasons for termination	Remarks
1	2	3	4	5	6	7	8	9	10	11	12

**FORM XVI**  
**[(See Rule 78 (2) (a))]**  
**MUSTER ROLL**

Name & Address of Contractor \_\_\_\_\_

Name & Address of establishment under which contract is carried on \_\_\_\_\_

Nature & location of work \_\_\_\_\_

Name & Address of Principal Employer \_\_\_\_\_ For the month/fortnight \_\_\_\_\_

Sl.No.	Name of Workman	Sex	Father's/Husband's Name	Dates					Remarks	
				1	2	3	4	5		
1	2	3	4	5					6	

**FORM XVII**  
**[See Rule 78 (2) (a)]**  
**REGISTER OF WAGE**

Name & Address of Contractor \_\_\_\_\_

Name & Address of establishment under which contract is carried on \_\_\_\_\_

Nature & location of work \_\_\_\_\_

Name & Address of Principal Employer \_\_\_\_\_ Wage period : Monthly/Fortnightly \_\_\_\_\_

Sl. No.	Name of workman	Sl. No. in the register of workman	Designation /nature of work done.	No. of days worked	Unit of work done	Daily rate of wages / piece rate	Basic wages	Dearness allowance	Overtime	Other cash payment (nature of payment to be indicated)	Total	Deduction if any (indicate nature)	Net amount paid	Signature/Thumb impression of workman.	Initials of contractor or his representative
1	2	3	4	5	6	7	8	9	10	11	12	13	14	15	16

Wage Card No. \_\_\_\_\_

**(Obverse) Appendix 'VII'**

**WAGE CARD**

Name & Address of Contractor \_\_\_\_\_

Date of issue \_\_\_\_\_

Name and location of work \_\_\_\_\_

Designation \_\_\_\_\_

Name of work man \_\_\_\_\_

Month/Fortnight \_\_\_\_\_

Rate of Wages \_\_\_\_\_

1	2	3	4	5	6	7	8	9	10	11	12	13	14	15	16	17	18	19	20	21	22	23	24	25	26	27	28	29	30	31
Morning																														
Evening																														
Initial																														

Received from \_\_\_\_\_

the sum of Rs. \_\_\_\_\_ on account of my wages

Signature

The Wages Card is valid for one month from the date of issue.



**FORM XIX**  
**[See Rule 78(2) (b)]**

**Wages Slip**

Name and address of contractor.....

Name and Father's/Husband's name of workman.....

Nature and location of work.....

For the Week/Fortnight/Month ending.....

1. No. of days worked.....
2. No. of units worked in case of piece rate workers.....
3. Rate of daily wages/piece rate .....
4. Amount of overtime wages.....
5. Gross wages payable.....
6. Deduction, if any.....
7. Net amount of wages paid.....
8. Initials of the contractor or his representative
9. Name and location of work Designation

---

**Initial of the Contractor or  
His representative**

**FORM XIV**  
**[See Rule 76]**  
**EMPLOYMENT CARD**

**Employment Card**

Name and address of contractor-----

Name and address of establishment under which contract is carried on-----

Name of work and location of work-----

Name and address of Principal Employer-----

1. Name of the workman-----

2. SI. No. in the register of workman employed-----

3. Nature of employment/designation-----

4. Wage rate (with particulars of unit in case of piece work)-----

5. Wage period-----

6. Tenure of employment-----

7. Remarks-----

\_\_\_\_\_  
Signature of Contractor

**FORM XV**  
**[See Rule 77]**  
**SERVICE CERTIFICATE**

Name & Address of Contractor \_\_\_\_\_  
 Nature & location of work \_\_\_\_\_  
 Name & Address of Workman \_\_\_\_\_  
 Age or date of birth \_\_\_\_\_  
 Identification Mark \_\_\_\_\_  
 Father's/Husband's name \_\_\_\_\_  
 Name and address of establishment in/under which contract is carried on \_\_\_\_\_  
 Name and address of principal employer \_\_\_\_\_

Sl. No.	Total period for which employed		Nature of work done	Rates of wage (with Particulars of Unit in case of piece work)	Remarks
	From	To			
1	2	3	4	5	6

Signature

**LIST OF ACTS AND OMISSIONS FOR WHICH FINES CAN BE IMPOSED**

In accordance with rule 7 (v) of C.P.W.D. Contractor's Labour Regulations to be displayed prominently at the site of work both in English and local Language.

1. Wilful insubordination or disobedience, whether alone or in combination with other.
2. Theft, fraud or dishonesty in connection with the contractors beside a business or property of Central Warehousing Corporation.
3. Taking or giving bribes or any illegal gratifications.
4. Habitual late attendance.
5. Drunkenness, fighting, riotous or disorderly or indifferent behaviour.
6. Habitual negligence.
7. Smoking near or around the area where combustible or other materials are locked.
8. Habitual indiscipline.
9. Causing damage to work in the progress or to property of the Central Warehousing Corporation or of the contractor.
10. Sleeping on duty.
11. Malingering or slowing down work.
12. Giving of false information regarding name, age, father's name etc.
13. Habitual loss of wage cards supplied by the employers.
14. Unauthorised use of employers property of manufacturing or making of unauthorised articles at the work place.
15. Bad workmanship in construction and maintenance by skilled workers which is not approved by the Corporation and for which the contractors are compelled to undertaken rectifications.
16. Making false complaints and/or misleading statements.
17. Engaging on trade within the premises of the establishments.
18. Any unauthorised divulgence of business affairs of the employees.
19. Collection or canvassing for the collection of any money with in the premises of an establishment unless authorised by the employer.
20. Holding meeting inside the premises without previous sanction of the employers.
21. Threatening or intimidating any workman or employee during the working hours within the premises.

**FORM XII**  
**[See rule 78 (2) (d)]**  
**REGISTER OF FINES**

Name & Address of Contractor \_\_\_\_\_

Name & Address of establishment in/under which contract is carried on \_\_\_\_\_

Name & location of work \_\_\_\_\_

Name & Address of Principal Employer \_\_\_\_\_

Sl · N o.	Name of workm an	Father's/ Husbands name	Designation/ nature of employment	Act/ Omission for which fine imposed	Date of offence	Whether workman showed cause against time	Name of person in whose presence employee's explanation was heard	Wage periods and wages payable	Amount of fine imposed	Date on which fine realised	Remarks
1	2	3	4	5	6	7	8	9	10	11	12

**FORM XX**  
**[See Rule 78 (2) (d)]**  
**REGISTER OF DEDUCTION FOR DAMAGE OR LOSS**

Name & Address of Contractor \_\_\_\_\_

Name & Address of establishment in/under which contract is carried on \_\_\_\_\_

Nature & Location of work \_\_\_\_\_

Name & Address of Principal Employer \_\_\_\_\_

Sl. No.	Name of workman	Father's /Husband's name	Designation/nature of employment	Particulars of damage or loss	Date of damage or loss	Whether workman showed cause against deduction	Name of person in whose presence employee's Explanation was heard	Amount of deduction imposed	No. of instalments	Date of Recovery		Remarks
										First instalment	Last instalment	
1	2	3	4	5	6	7	8	9	10	11	12	13

**FORM XXII**  
**[See Rule 78 (2) (d)]**  
**REGISTER OF ADVANCE**

Name & Address of Contractor \_\_\_\_\_

Name & Address of establishment in/under which contract is carried on \_\_\_\_\_

Nature & Location of work \_\_\_\_\_

Name & Address of Principal Employer \_\_\_\_\_

Sl. No.	Name of workman	Father's/ Husband's Name	Designation/ nature of employment.	Wage period and wages payable	Date & Amount of advance given	Purpose(s) for which advance made	No. of instalments by which advance to be paid	Date & amount of each instalment repaid	Date on which last instalment was repaid	Remarks
1	2	3	4	5	6	7	8	9	10	11

**FORM XXIII**  
**[See Rule 78 (2) (e)]**  
**REGISTER OF OVER TIME**

Name & Address of Contractor \_\_\_\_\_

Name & Address of establishment in/under which contract is carried on \_\_\_\_\_

Nature \_\_\_\_\_ & \_\_\_\_\_ Location \_\_\_\_\_ of work \_\_\_\_\_

Name & Address of Principal Employer \_\_\_\_\_

Sl. No.	Name of workman	Father's/ Husband's name	Sex	Designation/ Nature of employment	Date on which Overtime worked	Total over time worked or production in case of piece rated	Normal rate of wages	Overtime rate of wages	Overtime earnings	Rate on which overtime wages paid	Remarks
1	2	3	4	5	6	7	8	9	10	11	12



**Notice for appointment of arbitrator  
[Refer Clause 25]**

To,  
The Managing Director  
Central Warehousing Corporation  
CORPORATE OFFICE  
4/1, Siri Institutional Area,  
August KrantiMarg, HauzKhas,  
New Delhi-110016

Dear Sir,

In terms of clause 25 of the agreement, particulars of which are given below, I/we hereby give notice to you to appoint an arbitrator for settlement of disputes mentioned below:

1. Name of applicant
2. Whether applicant is Individual/Prop. Firm/Partnership Firm/Ltd. Co.
3. Full address of the applicant
4. Name of the work and contract number in which arbitration sought
5. Name of the Office which entered into contract
6. Contract amount in the work
7. Date of contract
8. Date of initiation of work
9. Stipulated date of completion of work
10. Actual date of completion of work (if completed)
11. Total number of claims made
12. Total amount claimed
13. Date of intimation of final bill (if work is completed)
14. Date of payment of final bill (if work is completed)
15. Amount of final bill (if work is completed)
16. Date of request made to Engineer-in-charge for decision
17. Date of receipt of Engineer-in-charge's decision
18. Date of appeal to you
19. Date of receipt of your decision.

Specimen signatures of the applicant  
(only the person/authority who  
signed the contract should sign)

I/We certify that the information given above is true to the best of my/our knowledge. I/We enclose following documents.

1. Statement of claims with amount of claims.
- 2.
- 3.

Yours faithfully,

(Signature)

Copy in duplicate to:

1. The Engineer-in-charge,

**FORM OF APPLICATION BY THE CONTRACTOR FOR SEEKING RESCHEDULING  
OF MILESTONES  
(Refer Clause 5.3)**

- 1. Name of contractor**
- 2. Name of work as given in the agreement**
- 3. Agreement no.**
- 4. Estimated amount put tender**
- 5. Date of commencement of work as per agreement**
- 6. Period allowed for completion of work as per agreement**
- 7. Date of completion stipulated in agreement**
- 8. Rescheduling of milestones done previously**

Milestone No. Already Reschedules	EE's Letter No. and Date	Rescheduling of Milestones Done	
		Original Date	Rescheduled Date
(A) 1st Milestone			
(B) 2nd Milestone			

**Rescheduling of Milestone applied for**

Milestone No. For Which Rescheduling is Applied	Original/ Reschedule d Date	Details and Period of Hindrances	Comments of Executive Engineer	Proposed Rescheduled Date of
(A) 1st Milestone				
(B) 2nd Milestone				
.....				

**Submitted to the Chief Engineer/ Superintending Engineer  
Contractor**

**Signature of**

**Dated**

**FORM OF APPLICATION BY THE CONTRACTOR FOR SEEKING EXTENSION OF TIME**

1. Name of Contractor
2. Name of work as given in the agreement
3. Agreement no.
4. Estimated amount put tender
5. Date of commencement of work as per agreement
6. Period allowed for completion of work as per agreement
7. Date of completion stipulated in agreement
8. Period for which extension of time if has been given by authority in Schedule ‘F’ previously

	Letter no. and date	Extension granted	
		Months	Days
(a) 1st extension			
(b) 2nd extension			
(c) 3rd extension			
(d) 4th extension			
(e) Total extension previously given			

9. Reasons for which extension have been previously given (copies of the previous applications should be attached)
10. Period for which extension applied for
11. Hindrances on account of which extension is applied for with dates on which hindrances occurred and the period for which these are likely to last (for causes under clause 5.2/ and 5.3).

Submitted to the Authority indicated in Schedule F with copy to the Engineer-in-Charge and Chief Engineer/ Superintending Engineer.

Signature of Contractor  
Dated

**INDENTURE FOR SECURED ADVANCES (Referred to in paragraphs 10.2.20 and 10.2.22  
of CPW A Code)**

(For use in cases in which the contract is for finished work and the contractor has entered into an agreement for the execution of a certain specified quantity of work in a given time)

THIS INDENTURE made the..... day of .....20..... BETWEEN ..... (hereinafter called the Contractor which expression shall where the context so admits or implies be deemed to include his executors administrators and assigns) of the one part and the CORPORATION (hereinafter called the President which expression shall where the context so admits or implies be deemed to include his successors in office and assigns) of the other part.

WHEREAS by an agreement dated..... (hereinafter called the said agreement) the Contractor has agreed AND WHEREAS the Contractor has applied to the President that he may be allowed advances on the security of materials absolutely belonging to him and brought by him to the site of the works the subject of the said agreement for use in the construction of such of the works as he has undertaken to execute at rates fixed for the finished work (inclusive of the cost of materials and labour and other charges) AND WHEREAS the President has agreed to advance to the Contractor the sum of Rupees ..... on the security of materials the quantities and other particulars of which are detailed in Accounts of Secured Advances attached to the Running Account Bill for the said works signed by the Contractor on .....and the President has reserved to himself the option of making any further advance or advances on the security of other materials brought by the Contractor to the site of the said works. Now THIS INDENTURE WITNESSETH that in pursuance of the said agreement and in consideration of the sum of Rupees .....on or before the execution of these presents paid to the Contractor by the President (the receipt whereof the Contractor doth hereby acknowledge) and of such further advances (if any) as may be made to him as aforesaid the Contractor doth hereby covenant and agree with the President and declare as follows: -

- (1) That the said sum of Rupees .....so advanced by the President to the Contractor as aforesaid and all or any further sum or sums advanced as aforesaid shall be employed by the Contractor in or towards expediting the execution of the said works and for no other purpose whatsoever.
- (2) That the materials detailed in the said Account of Secured Advances which have been offered to and accepted by the President as security are absolutely the Contractor's own property and free from encumbrances of any kind and the contractor will not make any application for or receive a further advance on the security of materials which are not absolutely his own property and free from encumbrances of any kind and the Contractor indemnifies the President against all claims to any materials in respect of which an advance has been made to him as aforesaid.
- (3) That the materials detailed in the said Account of Secured Advances and all other materials on the security of which any further advance or advances may hereafter be made as aforesaid (hereinafter called the said materials) shall be used by the Contractor solely in the execution of the said works in accordance with the directions of the Chief Engineer/ Superintending Engineer,

Corporate Office (hereinafter called the Chief Engineer/ Superintending Engineer) and in the term of the said agreement.

(4) That the Contractor shall make at his own cost all necessary and adequate arrangements for the proper watch, safe custody and protection against all risks of the said materials and that until used in construction as aforesaid the said materials shall remain at the site of the said works in the Contractor's custody and on his own responsibility and shall at all times be open to inspection by the Chief Engineer/ Superintending Engineer or any officer authorised by him. In the event of the said materials or any part thereof being stolen, destroyed or damaged or becoming deteriorated in a greater degree than is due to reasonable use and wear thereof the Contractor will forthwith replace the same with other materials of like quality or repair and make good the same as required by the Chief Engineer/ Superintending Engineer.

(5) That the said materials shall not on any account be removed from the site of the said works except with the written permission of the Chief Engineer/ Superintending Engineer or an officer authorised by him on that behalf.

(6) That the advances shall be repayable in full when or before the Contractor receives payment from the Corporation of the price payable to him for the said works under the terms and provisions of the said agreement. Provided that if any intermediate payments are made to the Contractor on account of work done than on the occasion of each such payment the Corporation will be at liberty to make a recovery from the Contractor's bill for such payment by deducting there from the value of the said materials then actually used in the construction and in respect of which recovery has not been made previously, the value for this purpose being determined in respect of each description of materials at the rates at which the amounts of the advances made under these presents were calculated.

(7) That if the Contractor shall at any time make any default in the performance or observance in any respect of any of the terms and provisions of the said agreement or of these presents the total amount of the advance or advances that may still be owing to the Corporation shall immediately on the happening of such default be repayable by the Contractor to the Corporation together with interest thereon at twelve per cent per annum from the date or respective dates of such advance or advances to the date of e-payment and with all costs charges, damages and expenses incurred by the Corporation in or for the recovery thereof or the enforcement of this security or otherwise by reason of the default of the Contractor and the Contractor hereby covenants and agrees with the Corporation to repay and pay the same respectively to him accordingly.

(8) That the Contractor hereby charges all the said materials with the repayment to the Corporation of the said sum of Rupees .....and any further sum or sums advanced as aforesaid and all costs charges, damages and expenses payable under these presents PROVIDED ALWAYS and it is hereby agreed and declared that notwithstanding anything in the said agreement and without prejudice to the powers contained therein if and whenever the covenant for payment and repayment herein before contained shall become enforceable and the money owing shall not be paid in accordance therewith the Corporation may at any time thereafter adopt all or any of the following courses as he may deem best :-

(a) Seize and utilize the said materials or any part thereof in the completion of the said works on behalf of the Contractor in accordance with the provisions in that behalf contained in the said agreement debiting the Contractor with the actual cost of effecting such completion and the amount due in respect of advances under these presents and crediting the Contractor with the value of work done as if he had carried it out in accordance with the said agreement and at the

rates thereby provided. If the balance is against the Contractor he is to pay same to the Corporation on demand.

(b) Remove and sell by public auction the seized materials or any part thereof and out of the moneys arising from the sale retain all the sums aforesaid repayable or payable to the Corporation under these presents and pay over the surplus (if any) to the Contractor.

(c) Deduct all or any part of the moneys owing out of the security deposit or any sum due to the Contractor under the said agreement.

(9) That except in the event of such default on the part of the Contractor as aforesaid interest on the said advance shall not be payable.

(10) That in the event of any conflict between the provisions of these presents and the said agreement the provisions of these presents shall prevail and in the event of any dispute or difference arising over the construction or effect of these presents the settlement of which has not been herein before expressly provided for the same shall be finally resolved as per provisions of clause 25 of the contract.

In witness whereof the said .....and .....by the order and under the direction of the Corporation have hereunto set their respective hands the day and year first above written

Signed, sealed and delivered by..... the said contractor in the presence of

Signature .....

Witness Name .....

.....

Address .....

Signed by..... by the order and direction of the Engineer-in-charge in the presence of

Signature .....

Witness Name .....

.....

Address .....

**INDEMNITY BOND**

(On non-judicial stamp paper of appropriate value)

Name of the work -----  
-----  
-----

Know all men by these presents that I/we \_\_\_\_\_

Name of Contractor with address \_\_\_\_\_

Do hereby execute Indemnity Bond on \_\_\_\_\_ day of \_\_\_\_\_ 2018 in favor of (I) CENTRAL WAREHOUSING CORPORATION, CORPORATE OFFICE 4/1, SiriInstitutional Area, August KrantiMarg, HauzKhas, New Delhi-110016 and

(II) .....appointed as the Engineers for the Project Management for and on behalf of CWC for the work of .....vide Tender No. ....

**THIS DEED WITNESSETH AS FOLLOWS:**

I/We \_\_\_\_\_ (Name of contractor) hereby do indemnify and save harmless CWC & ..... having their office at 4/1, SiriInstitutional Area, August KrantiMarg, HauzKhas, New Delhi-110016and ..... respectively from:

- (1) Any third party claims, civil or criminal complaints/liabilities, site mishaps and other accidents or disputes and/or damages occurring or arising out of any mishaps at the site due to faulty work, negligence, faulty construction and/or by violation of any law, rules and regulations in force, for the time being while executing/executed civil works by me/us.
- (2) Any damage, loss or expenses due to or resulting from any negligence or breach of duty on the part of me/us or any sub-contractor, if any, servants or agents.
- (3) Any claims by an employee of Mine/ours or of sub-contractor(s) if any, under the Workman Compensation Act and Employers' Liability act, 1939 or any other law, rules and regulations in force for the time being and any acts replacing and/or amending the same or any of the same as may be in force at the time and under any law in respect of injuries to persons or property arising out of and in the course of execution of the contract, work and/or arising out of and in the course of employment of any workman/employee.

(4) Any Act or omission of mine/ours or sub-contractors if any. Our/their servants or agent which may involve any loss, damage, liability, civil or criminal action.

IN WITNESS WHEREOF THE.....

HAS SET HIS/THEIR HANDS ON THIS DAY OF ..... **20...**

SIGNED AND DELIVERED BY THE

AFORESAID.....

IN THE PRESENCE OF WITNESS

1. ....

2. ....



**Section-IX**  
**(OPERATIVE SCHEDULES)**

## SCHEDULES

(Operative Schedules to be supplied separately to each intending Tenderer)

### SCHEDULE 'A'

Schedule of quantities

(Enclosed with NIT)

### SCHEDULE 'B'

Schedule of materials to be issued to the contractor.

S.No.	Description of item	Quantity	Rates in figures & words at which the material will be charged to the contractor	Place of Issue
1	2	3	4	5
	NIL i.e. CWC shall not issue any material to Contractor for incorporating in the work against this NIT.	NIL	Not applicable	Not applicable

### SCHEDULE 'C'

Tools and plants to be hired to the contractor

Sl.No.	Description	Hire charges per day	Place of Issue
1	2	3	4
	NIL i.e. CWC shall not issue any material to Contractor for incorporating in the work against this NIT.	Not applicable	Not applicable

### SCHEDULE 'D'

Extra schedule for specific requirements/document for the work, if any .....NIL...

### SCHEDULE 'E'

Name of work: Major repairs and strengthening to Gable walls of Godown No. 2A to avoid differential settlement and remedial measures including Piling at CW gadag-II,( Karnataka)

Estimated cost of work: Rs.35,87,578/-.

i) Earnest money: Rs. 71,800/- (to be adjusted in Security Deposit of Successful Bidder)

ii) Performance Guarantee 5% of tendered value.

- iii) Security 2.5% of tendered value.  
 Deposit: OR

2.5% of tendered value plus 50% of PG for contracts involving maintenance of the building and services/ other work after construction of same building and services/ other work.

## SCHEDULE 'F'

**GENERAL** Officer inviting tender As per NIT  
**RULES &**  
**DIRECTIONS**

Maximum percentage for quantity of items of work to be executed beyond which rates are to be determined in accordance with Clauses 12.2 & 12.3 30% in Superstructure  
100% in foundation

### Definitions:

- 2(v) Engineer-in-Charge Superintending Engineer  
 2(viii) Accepting Authority As per DOP of CWC  
 2(x) Percentage on cost of materials and labour to cover all overheads and profits. 15%  
 2(xi) Standard Schedule of Rates DSR 2016 & NSI 2016 (based on DSR 2016).  
 2(xii) Department CWC

### Clause 1

- (i) Time allowed for submission of Performance Guarantee, **Programme Chart (Time and Progress) and applicable labour licenses, registration with EPFO, ESIC and BOCW Welfare Board or proof of applying thereof from the date of issue of letter of acceptance 15 days.**
- (ii) Maximum allowable extension with late fee @ 0.1% per day of Performance Guarantee amount beyond the period provided in (i) above 15 days

### Clause 2

Authority for fixing compensation under clause 2: As per DOP of CWC

### Clause 2A

**DELETED**

### Clause 5

Number of days from the date of issue of letter of acceptance for reckoning date of start....**15**.... days

Mile stone(s) as per table given below: -

SI.No.	Description of Milestone (Physical)	Time Allowed in days (from date of start)	Amount to be with-held in case of non-achievement of milestone
1.			
2.			
3.			
3.			

Time allowed for execution of work. 90 Days from the date of START.

**Authority to decide:**

- (i) Extension of time: As per DOP in CWC
- (ii) Rescheduling of mile stones: Engineer in Charge.
- (iii) Shifting of date of start in case of delay in handing over of site: Engineer in Charge.

**Schedule of handing over of site**

Part	Portion of site	Description	Time Period for handing over reckoned from date of issue of letter of Acceptance
Part A	Portion without any hindrance	100 % site area is available without any Hindrance.	15 Days i.e on Stipulated date of START.
Part B	Portions with encumbrances	-	-
Part C	Portions dependent on work of other agencies	-	-

**Schedule of Issue of Designs**

Part	Portion of design	Description	Time Period for issue of design reckoned from date of issue of letter of Acceptance.
Part A	Portion already included in NIT	All Concept design/drawings to be provided by CWC are already included in NIT. No special separate drawing is required.	
Part B-1	Portions of Architectural Designs to be issued		

Part B-2	Portions of Civil Designs to be issued		
Part B-3	Portions of E&M Designs to be issued		

**Clause 5.2**

**Nature of Hindrance Register (either Physical or Electronic):** Physical

**Clause 5.4**

**Schedule of rate of recovery for delay in submission of the modified programme in terms of delay days**

Sl. No.	Contract Value	Recovery Rs.
I.	Less than or equal to Rs. 1 Crore	500
II.	More than Rs. 1 Crore but less than or equal to Rs. 5 Crore	1000
III.	More than Rs. 5 Crore but less than or equal to Rs. 20 Crores	2500
IV.	More than 20 Crores	5000

**Clause 6, 6A**

Clause applicable – Clause 6 or Clause 6A: Clause 6A

**(Computerized Measurement book only)**

**Clause 7**

Gross work to be done together with net payment after adjustment of advances for material collected, if any, since the last such payment for being eligible to interim payment if work done payment is 5% or more of contract value  
Rs.....

**Whether Clause 7A shall be applicable**                      **Yes/No**

**Clause 8B**

- (i) **This shall not apply for maintenance or up gradation contracts not involving any services.**
- (ii) **For other works, the limit shall be as below:**

Sl. No.	Contract Value	Limit Rs.
I.	Less than or equal to Rs. 1 Crore	10,000

II.	More than Rs. 1 Crore but less than or equal to Rs. 5 Crore	35,000
III.	More than Rs. 5 Crore but less than or equal to Rs. 20 Crores	1,00,000
IV.	More than 20 Crores	2,00,000

**Clause 10A**

List of testing equipment to be provided by the contractor at site lab.

Slump Cone	Measuring Instrument Taps etc.	Auto Level

**Clause 10B(ii) DELETED**

**Clause 10C DELETED**

**Clause 10CA DELETED**

Sl.No.	Materials Covered under this clause:	Nearest Materials (other than cement*, reinforcement bars, the structural steel and POL) for which All India Wholesale Price Index to be followed:	Base Price and its corresponding period of all the Materials covered under clause 10 CA
1			

\* includes Cement component used in RMC brought at site from outside approved RMC plants, if any.

\*\* Base price and its corresponding period of all the materials covered under clause 10 CA is to be mentioned at the time of approval of NIT. In case of recall of tenders, the base price may be modified by adopting latest base price and its corresponding period.

**Clause 10CC DELETED**

Clause 10 CC to be applicable in contracts with stipulated period of completion exceeding the period shown in next column ..... months  
 Schedule of component of other Materials, Labour etc. for price escalation.  
 Component of civil (except materials covered under clause 10CA) /Electrical construction Xm ..... %  
 value of work. -  
 Component of Labour - Y ..... %  
 expressed as percent of total value of work.

**Note :** Xm.....% should be equal to (100) - (materials covered under clause 10CA i.e. Cement, Steel, POL and other material specified in clause 10CA + Component of Labour )

**Clause 11**

Specifications to be	CPWD Specifications Vol-I& II 2009 for Civil Works
----------------------	--

followed for execution of work	and CPWD General Specifications for Electrical Works Part-I(Internal) 2013&Part-II (External) 1994 with up to date correction slips.
--------------------------------	--

**Clause 12**

Type of work \*\*\* Original Work

\*\*\*To be filled by NIT approving authority either Project and original, work or Maintenance works including works of aesthetic, special repair, addition/ alteration in buildings. The items related to road work like upgradation, improvement of carriage way by patch repair or annual/periodical repairs of road surface and A/R & M/O works pertaining to road shall be treated as maintenance work.

New road construction works, replacement of AC sheet roofing with Galvalumepre-coated steel sheet roofing and the strengthening of floor & road surface shall be considered as original works.

12.2 & 12.3	Deviation Limit beyond which clause 12.2 & 12.3 shall apply for building work	As per provision of CPWD Manual applicable as on date of opening of tenders
12.5	(i) Deviation Limit beyond which clauses 12.2 & 12.3 shall apply for foundation work (except items mentioned in earth work subhead in DSR and related items) (ii) Deviation Limit for items mentioned in earthwork subhead of DSR and related items	As mentioned above.

**Clause 16**

Competent Authority for deciding reduced rates.

As per DOP in CWC

**Clause 18**

List of mandatory machinery, tools & plants to be deployed by the contractor at site:-

1. Concrete Mixture	2. Excavator (as and when required)	3. Hydra Crane (As and when required)
---------------------	-------------------------------------	---------------------------------------

**Clause 25**

Constitution of Dispute Re-dressal Committee (DRC)

Chairman - Chief Engineer

Member - DGM (Finance)

Member - DGM (G)

1. Place of Arbitration- New Delhi

Clause 36 (i)

Requirement of Technical Staff for a Work and Rate of recovery

SI. No.	Cost of Work (Rs. In Lakh)	Minimum Qualification of Technical Representative	Discipline	Designation (Principal Technical/Technical representative)	Minimum Experience	Number	Rate at which recovery shall be made from the contractor in the event of not fulfilling provision of clause 36(i)
1.	1000 to 2000	(i) Project Manager with Degree in corresponding discipline of Engineering. (ii) Graduate Engineer. (iii) Graduate Engineer Or Diploma Engineer	Civil	Principal Technical Representative	10 Years	1	Rs. 30,000/-p.m.
				Technical Representative	5 Years	1	Rs. 25,000/-p.m.
				Project/Site Engineer and Project Planning/billing Engineer	2 Years	2	Rs. 15,000/-p.m.
				Project/Site Engineer and Project Planning/billing Engineer	5 Years	2	Rs. 15,000/-p.m.
2.	500 to 1000	(i) Graduate Engineer. (ii) Graduate Engineer Or Diploma Engineer	civil	Principal Technical Representative	5 Years	1	Rs. 25,000/-p.m.
				Project/Site Engineer And Engineer	2 Years	2	Rs. 15,000/-p.m.
				Project/Site Engineer And Engineer	5 Years	2	Rs. 15,000/-p.m.
3.	Upto 500 Lacs	Graduate Engineer Or Diploma Engineer	Conc ern Disci pline	Principal Technical Representative	2 Years	1	Rs. 15,000/-p.m.
				(Project Planning/Site/billing Engineer)	5 Years	1	Rs. 15,000/-p.m.



Assistant Engineers retired from Government services that are holding Diploma will be treated at par with Graduate Engineers.

Diploma holder with minimum 10 years relevant experience with a reputed construction co. can be treated at par with Graduate Engineers for the purpose of such deployment subject to the condition that such diploma holders should not exceed 50% of requirement of degree engineers.

**Clause 42**

(I) (a) Schedule/statement for determining theoretical quantity of cement & bitumen on the basis of Delhi Schedule of Rates 2016 printed by C.P.W.D.

(II) Variations permissible on theoretical quantities:

(a) Cement

For works with estimated cost put to tender not more than Rs. 5 lakh. 3% plus/minus.

For works with estimated cost put to tender more than Rs.5 lakh. 2% plus/minus.

(b) Bitumen All Works 2.5% plus & only & nil on minus side.

(c) Steel Reinforcement and structural steel sections for each diameter, section and category 2% plus/minus

(d) All other materials. Nil

**RECOVERY RATES FOR QUANTITIES BEYOND PERMISSIBLE VARIATION**

Sl.No.	Description of Item	Rates in figures and words at which recovery shall be made from the Contractor	
		Excess beyond permissible variation	Less use beyond permissible variation
1.	Cement		
2.	Steel reinforcement		
3.	Structural Sections		
4.	Bitumen issued free		
5.	Bitumen issued at stipulated fixed price		

**SECTION – X**  
**(TECHNICAL CONDITIONS/SPECIFICATIONS)**

# TECHNICAL SPECIFICATIONS FOR CIVIL WORKS

## 1.0 GENERAL

### 1.1 SCOPE

These specifications establish and define the materials and constructional requirements for civil engineering construction works in brief.

### 1.2 EQUIVALENCY OF STANDARDS AND CODES, MEASUREMENTS & MATERIALS

- 1.2.1 Wherever reference is made in the contract to specific standards and codes to be met by the goods and materials to be furnished, and work performed or tested, the provisions of the latest current edition or revision of the relevant standards and codes in effect shall apply, unless otherwise expressly stated in the contract. In case, no reference is made for any particular work, relevant IS /BIS Codes will be followed.
- 1.2.2 Providing and operating necessary measuring and testing devices and materials including all consumables are included in the Scope of Work. No separate measurement or payment for testing the work shall be made but rates quoted for various items shall be deemed to include cost of such tests, which are required to ensure achievement of specified quality.
- 1.2.3 All materials shall be of standard quality, manufactured by renowned concerns, conforming to Indian Standards and shall have certification work from Bureau of Indian Standards as far as possible, unless otherwise approved by Engineer. The contractor shall get all materials approved by Engineer prior to procurement and use. The contractor shall furnish manufacturer's certificates, for materials supplied by him when asked for. Further to that he shall get materials tested from an approved Test House, if asked for by the Engineer. The cost for all the tests and test certificates shall be borne by the contractor. No separate payment shall be made for the testing. The Engineer shall have the right to determine whether all or any of the materials are suitable. Any materials procured or brought to site and not conforming to specifications and satisfaction of the Engineer shall be rejected and the contractor shall have to remove the same immediately from site at his own expense and without any claim for compensation due to such rejection.
- 1.2.4 All goods and materials to be incorporated in the works shall be new, unused, of the most recent or current models and incorporate all recent improvements in design and materials, unless provided otherwise in the contract.

- 1.2.5 Wherever referred to in this tender document, only the latest revision of Specifications, Codes of Practice and other publications of the Indian Standards shall be applicable.

## **2.0 WORK SPECIFICATIONS**

The works will be executed, as indicated in the nomenclature of each items, Bill of Quantities, Drawings, Specification and Terms and Conditions read in conjunction with those given in this Contract.

### **2.1 Site Clearance:**

Before the earthwork is started, the area coming under cutting and filling shall be cleared of shrubs, rank vegetation, grass, brushwood, trees and sapling of girth up to **30cm.** measured at a height of one meter above ground level and rubbish removed outside boundary. The roots of trees and saplings shall be removed to a depth of **60 cm.** below ground level or 30 cm below formation level or **15cm** below sub-grade level whichever is lower and holes or hollows filled up with the earth, rammed or leveled. Payment of this item of site clearance will be made as per relevant item in BOQ.

### **2.2 Brick Masonry Wall**

Bricks used shall have compressive strength not less than 7.5 MPa. Other specifications shall be as per Railway/ CPWD Specifications. In case bricks of compressive strength 7.5 MPa are not available and the structure is not of load bearing nature, then use of less compressive strength bricks can be relaxed as per CPWD specification, at reduced rate as worked out by the Engineer in-charge.

All brick Masonry work as mentioned in this schedule of quantities shall be done with the available size of F.P.S. Bricks conforming to CPWD specifications with up to date correction slips. For the measurement of the brick work, it would be in the multiples of the half brick. Above three bricks, the brick work would be measured as per the actual thickness.

The 'Modular bricks' "shall only be used where use of same is specifically mentioned in the relevant items." In such cases the modular Bricks shall also conform to CPWD specifications and mode of measurement would be the same as mentioned in above para.

### **2.3 Concrete work**

All mixed design concrete shall be executed by Concrete Batch Mix Plant of suitable capacity, to be installed by Contractor at site. In special cases RMC shall be allowed by Engineer on written request of the contractor but the RMC should also be from a plant of appropriate capacity. **No extra payment shall be allowed on account of Concrete from batch mix plant or RMC.**

If at any stage of the work, during or after placing the concrete in the structure the work is found defective such concrete shall be removed and work be done with fresh concrete and adequate rigid forms at the cost of the contractor. The contractor shall be liable to bear the cost for the cement concrete thus dismantled.

The construction work shall be done with proper and assured system of curing duly identified areas with dates marked in paint. In hot weather the contractor shall take relevant care to cover the work with wet gunny bags/hessian cloth or use continuous ponding of water on surface so as to keep the surface wet.

#### 2.4 **Fine Aggregates**

Coarse sand of approved quality conforming to relevant IS code shall be used as fine aggregate. For cement concrete, reinforced cement concrete and concrete of any other type, sand / quarries dust shall be cleaned and absolutely free from dirt and no other deleterious material shall be permitted. Samples of sand to be used shall be approved by Engineer-in-charge or his authorised representative.

The sand used in various items of work shall generally conform to the CPWD specifications for works 2009 Volume-I with up to date correction slips.

The sand to be used in brick masonry, concrete and R.C.C. shall have a fineness modulus of not less than 2.5 except for items otherwise specified in schedule of quantities and CPWD specifications and shall be obtained from nearest approved quarry and the material to be in conformity with the CPWD specifications.

The sand used in items where use of 'Fine Sand' is mentioned in schedule of quantities and in all items under 'Finishing' (shall have a fineness modulus of not less than 1.0) and shall be obtained from nearest approved quarry.

#### 2.5 **Coarse Aggregate**

The coarse aggregate which may be either stone ballast or stone chips as directed, should be well graded and preferably machine broken and should conform to CPWD Specifications and /or relevant IS code and should be obtained from approved quarries. The stone should be free from soft thin elongated or laminated or decayed particles. The aggregates should be free from dust. Cleaning and washing, if necessary, should be carried out as per the direction of the Engineer or his authorised representative.

The mention of any sources does not, however, absolve the contractor's for his / their liability to ensure that the coarse sand, stone chips and ballast as may be required for the work strictly in accordance with Standard Specification .In case, these materials cannot be had according to specification, from these sources the contractor may bring the materials from any other sources by obtaining prior permission of the Engineer – in- charge, provided materials are according to standard specifications.

In addition to the routine tests, special tests on materials will be carried out whenever required by the Engineer. The cost of the special test done will be borne by the contractor. Necessary facilities in the form of moulds, cones, scales materials, labour for casting, curing, specimen and such other facilities as pre –requisite to any standard concrete tests will in any case be afforded by the contractor free of cost.

## 2.6 Form work and shuttering

For cement concrete in slabs, columns, beams, chajjas, etc, the contractor should use water proof plywood / steel shuttering plate sets as per the drawing. The steel plate should have smooth surface and should be free of bulge during the concreting. The entire shuttering should be water proof and conform to relevant IS Code. If however, the contractor wants to use wooden shuttering, he will have to use new planks and scanting, for fabrication of such shuttering so as to ensure smooth and leak proof surface.

## 2.7 Reinforcement

Binding wire of approved quality shall be arranged by the contractor himself and the rates quoted for RCC work will includes cost of binding wire and the process, of binding etc,

All works shall be done strictly in accordance with the approved drawings and no departure shall be made by the contractor without the order of the Engineer in writing.

## 2.8 Paint

Standard brands of paints and primers as per relevant IS code or as specified, all labour and materials, cleaning materials, ladder scaffolding, tools plant and equipment's including brushes of approved /pattern of contractor expenses.

## 2.9 Preparation of sub-grade

Where the pavement is to be laid on surface obtained after cutting the soil, the sub-grade for pavement shall be prepared as per specifications relevant to item in BOQ for achieving not less than 97% of dry density as per IS : 2720 Part VIII at no extra cost or otherwise as per the procedure mentioned hereafter.

The sub-grade shall be excavated to a depth of 0.5 meter, watered and compacted in layers not exceeding 250mm thickness, dressing to required camber and profile and consolidation with vibratory roller of 80 to 100 KN static weight so as to achieve not less than 97% of dry density as per IS : 2720 Part VIII. However, before relaying and compacting the loosened material the surface below this level shall be suitably consolidated as directed by the Engineer but with a minimum six passes of vibratory roller. If the next 15 cm below this level does not have a relative compaction of 90%, it shall be compacted until not less than 95% dry density is obtained. Rate for work of this nature shall be covered in the item of preparation of sub-grade. Where the pavement is to be laid on fill and height of proposed fill is less than 0.5 meter, the procedure for sub-grade preparation as mentioned above shall be followed.

Where the pavement is to be laid on fill and the height of proposed fill is more than 0.5 meter, preparation of sub-grade is not required at these locations, however, in such locations original ground level shall be compacted by rolling as directed by the Engineer as much as possible but with a minimum of six passes of vibratory roller of 80 to 100 KN static weight. No separate payment shall be made for this, as same shall covered in item of earth work in excavation and / or filling.

**2.10 Water Bound Macadam**

The standard specifications and code of practice for Water Bound Macadam as per IRC: 19-2005 shall apply to all road work.

The stone aggregate of Grade I, II & III as specified under the sub work of 'Roads' shall conform to IRC: 19-2005.

**2.11 Specification for Pavement Quality Concrete (PQC)**

The work of PQC pavement for road work shall be executed as per latest CPWD Specification and minimum cement content shall **not be less** than as specified for design mix cement concrete. However, if higher grade and of concrete is to be executed excess / less cement used as per design mix shall be payable / recoverable separately as per relevant BOQ item.

**2.12 Assembling and erection of the tubular cum structural steel trusses over column etc.**

2.12.1 The drawing for different components of steel trusses, purlins, etc. including accessories will be supplied by the Corporation to the contractor as he should see before quoting his rates, Before assembling the members, the contractor should remove the rust and clean them properly, straighten kinks, and form screw threads etc. for which nothing extra shall be paid. The completed truss work shall be true to the alignment to the entire satisfaction of Engineer-in-Charge. Any rectification required to get the truss work and purlins etc. to the proper alignment shall be carried out by the contractor without any extra payment. If any of the components of the tubular trusses or purlins or accessories are lost while in the custody of the contractor, the loss shall be made good by the contractor at his own cost.

2.12.2 Payment on weight basis would be made as per the theoretical or actual weight whichever is less.

2.12.3 Sheet roofing shall be completely leak proof and to the entire satisfaction of the Engineer-in-Charge. The contractor shall have to provide the overlaps as per the specifications of the relevant items and the sheets to be in conformity with the relevant codes as mentioned in the items. The measurement of the items of the sheeting will be done as laid down in the latest CPWD specifications/BIS Codes/as per the item.

2.12.4 Nothing extra shall be paid for rough cutting of bricks/stones for forming gable walls tapered masonry in long walls, gable/partition walls footing etc.

2.12.5 Top of platform coping shall be given a brush finish, if required, for which no extra payment shall be made.

2.12.6 The rate for roofing includes cutting of chases in masonry walls and filling the same with cement concrete as directed by the Engineer-in-Charge for fixing the roofing sheets over the platform. Nothing extra shall be paid for the same.

2.12.7 The cost of supplying bitumen is included in the items of applying bitumen on Damp proof course.

2.12.8 The rate to be quoted for making plinth protection should include cost of necessary earth work in excavation/filling and disposal of earth within a lead of 50 meters as directed by the Engineer-in-Charge.

2.12.9 The rate for steel windows, ventilators etc. include cost of all the fittings complete including M.S. Oxidised stays, handles etc. and nothing extra shall be paid for the same.

**2.13 Specification of Sheet & Item Related with The Pre-Coated Galvalume Profile Sheets.**

S. No.	ITEM DESCRIPTION	SPECIFICATION
<b>PRE-COATED GALVALUME PROFILE SHEET</b>		
1.	Depth	30 mm
2.	Pitch	200mm
3.	Total coating thickness	0.60mm
4.	Yield Strength	550MPa
5.	Galvalume	AZ-150
6.	Polyester paint & coating	20-25 micron RMP on exposed surface including primer and 7-10 epoxy coating on unexposed surface including primer
7.	Self drilling/tapping screws size	5.5x55mm with EPDM seal and washers of make-Coroshield/ Durotuff (as per the instruction of Engineer-in- Charge)
8.	Tolerance	As per relevant IS code

**2.14 Steel Rolling Shutters/M.S. Garage doors.**

Rolling shutters should be in general conforming to the detailed specifications In Delhi CPWD Specification 2009 Vol-I except for details as under:-

The shaft of rolling shutters shall be of M.S. Pipe heavy duty 40 mm. nominal bore, 48.3 mm outer dia, thickness 4.05 mm and weight of pipe shall be 4.43 Kg./metre. At least three springs made of H.T. steel grade 2 of I.S. 4454/1967 of 27.5 mm. length shall be used in each shutter. The guide channels of minimum 60 mm depth shall be made of 3.15 mm thick M.S. strips Lock rail at bottom shall be of 3.15 mm thickness with M.S. angle 35 mm x 35 mm x 5 mm welded at the bottom and brackets for fixing the M.S. pipe on wall shall be of M.S. plate 3.15 mm thick. Top cover of shutters shall be made out of M.S. Plate 1-25 mm thick sliding bolt for lock rail shall be made of M.S. flats not less than 50 mm x 6 mm size at both ends with inside and outside locking arrangement. Further details if any not covered by general specifications of Delhi CPWD specifications 2009 Volume I and details described above shall be as per IS specifications No.6248 of 1971/revision (latest)

The contractor shall arrange one more spring than the total required number, for testing purpose. The Engineer-in-Charge shall select at random one spring to be sent for test regarding grade of H.T. steel wire used in the springs. No extra payment shall be made for the additional spring arranged.

The rates to be quoted for supplying and fixing rolling shutter should include making necessary chases in masonry and making good the same for fixing of side guide etc.

Garage doors with frames should be provided as per the relevant drawing and in accordance with the details provided in the item.



## Technical specifications of turbo ventilators

Model	Standard
Central dia. of vanes	28 Inch (710mm)
Neck/Throat Diameter	21 Inch (530mm)
No. of Vanes(Blades)	36 Inch Vanes
Height	19 Inch (480mm)
Capacity at 25 ft height	1850 CFM
Base Ring	Stainless Steel
Top Cover	Stainless Steel
Top Plate MOC (material of construction)	Aluminium 1 mm Thickness Alloy 8011 H2
Vanes MOC	Aluminium 0.635mm Thickness
Bottom Ring	Aluminium 1.27mm Thickness
Rotation	Pivot bush support without Bearing
Pointer MOC	10 mm dia EN-8 with Electroplating
Centre Shaft	Derline black (Hardest PTE grade)
Inner Arms	M.S. 20mm with Electroplating
Outer Arms	M.S. 20mm dia with Electroplating
Centre Pipe	M.S. 20mm with Electroplating
Net Weight	5.8 Kgs. (Approx.)
Base Plate	3mm thick sky light Poly Carbonate Profile Sheet with 30 micron thick protective UV coating of make Lotus/Luxon/Bayer/Sabic
Packing	As per requirement
Poly Carbonate Ventury Dome	Poly Carbonate stretched from 3.00 mm thick sheet (1.5 mm thickness)
Miscellaneous Items Like 'J'-hooks/ Nuts & Bolts/ Self drilling/tapping screws size 5.5x55mm with EPDM seal and washers of make-Coroshield/ Durotuff (as per the instruction of Engineer-in- Charge)	Zinc plating or Galvanized
Sealing compound having mixture of Cobalt, fiber glass, resin and catalyst or silicone sealant and butyle water proofing tape should be used all around overlapping area of Poly Carbonate sheet,	Sealing of Joints/ over-lapping portion complete

- Powder Coating is done with Epoxy Polyester Powders for excellent corrosion resistance

## List of Approved Makes

S. Nr.	Name of Material	Make
	<b>Civil Items</b>	
1 (a)	Cement (Portland Pozzolana Cement)	ACC, Ultra Tech., J. P. Rewa, Vikram, Shree Cement, Lafarge cement, Mycem cement, Birla cements, Prism Cement, Ambuja Cement & Cement Corporation of India, JK Laxmi, Dalmia or Reputed manufacturers of Major plants approved by Engineer-in Charge whose cement confirming to latest IS Specification..
1 (b)	Cement (Ordinary Portland Cement)	Gujarat Ambuja, ACC, JK, Vikram, Shree, Ultratech, Birla Uttam, Binani, Lafarge, Madras Cement (Ramco), India Cement, Jaypee, Dalmia or Reputed manufacturers of Major plants approved by Engineer-in Charge whose cement confirming to latest IS Specification
2	Reinforcement Steel	TATA, SAIL, RINL, JINDAL or BIS approved Licence holder/ manufacturer
3	White Cement	Birla White, JK, Kamdhenu.
4	Ceramic Glazed Tile	Kajaria, Johnson and Somany (all first quality) or equivalent
5	Vitrified Floor Tile	Kajaria, Johnson and Somany (all first quality) or equivalent (Min. 10mm thickness & Grade-V)
6	Atactic poly-propylene (Membrane sheet)	Fibrex India Ltd, Polygamma Industries Pvt Ltd, and Industrial rubber products. (Minimum thickness 5.0 mm)
7	PVC drain Pipe	Supreme, Prakash, Kissan (Agro) (Min 6.0 kgf pressure or as/ Engineer's Instructions)
8.	CPVC water supply pipe	Astral, Supreme, Prakash & Prince (wall pressure Min 500 psi)
9.	G.I. Pipes	Jindal (Hissar), Prakash Surya, Tata or equivalent
10.	WC	Roca, Kohler and Hindware
11.	Wash Basin	Roca, Kohler and Hindware
12.	Urinal	Roca, Kohler and Hindware
13.	CP fitting	Grohe, Kohler and Hindware
14.	C.I. pipe & fitting	SKF, Electrosteel
15.	Aluminium frame	Jindal, Hindalco
16.	Float glass	Modi, St Gobains or HNGIL
17.	Toughened Glass	GSC, AIS, Assahi
18.	Frameless Glass fitting	Ozone or Dorma
19.	Pre-laminated board	Greenlam, Merino or Kitply
20.	Gypsum Board ceiling	Channels and board make of India Gypsum or Lafarz
21.	Grid Ceiling	Grid and tile of Armstrong make (ULTIMA regular panel and Silhouette XI 1/8" Reveal)
22.	POP punning	Sakarni, Shri Ram, JK
23.	Acrylic Paint	Asian, ICI (Dulux), Nerolac, Berger, Jhonson & Necolson
24.	Stainless Steel	Jindal, SAIL, Indian Stainless Steel

S. Nr.	Name of Material	Make
25.	G.I. Fittings	UNIK, ZOLOTO, NVR or equivalent
26.	Structural Steel	TATA, SAIL, Jindal, RINL,IISCO or Manufacturer having BIS approved Licence.
27.	Structural Steel- MS pipes only	TATA, Jindal, or Manufacturer having BIS approved Licence.
28.	Stainless Steel Hardware	Hettich, Godrej, Droma
29.	Stainless Steel Bolts, Washers & Nuts	Kundan, Puja, Atul
30.	Chequered Precast Concrete Tile	Hindustan Tiles, Ultra, Swatik Tiles
31.	PVC casing pipe	Kissan (Agro), Appollo& Supreme
32.	Plyboard& Ply	Green Ply, Kitply, Century
33.	Laminate	Greenlam, Merino, Century
34.	Wall putty	Birla, JK, Asian
35.	Submersible Pump	Crompton Greaves, Kirloskar, KSB
36.	Galvalume Sheets	TATABluescope, JSWcolouron, JSW Steel
37.	Self-drilling/ tapping Zinc plated screws size 5.5x55mm for Galvalume sheets	HILTI or equivalent

**NOTE:**Above makes are approved subject to their meeting the specifications. The contractor, however, shall seek approval of specific make from Engineer In-charge before commencing the work. The decision of Engineer in-charge shall be final and binding on the contractor in this respect.

(The availability of Approved make at local market should ensure during the preparation of detailed estimate and make of item should also indicate in estimate/Market rate list/ analysis of rates.)

## **TECHNICAL CONDITION AND SPECIFICATION FOR ELECTRICAL WORKS**

### **1. Tender Drawings and Construction Drawings:**

- 1.1 These drawings are meant for Tenderer's guidance only. "Approval for Construction" drawings will be furnished to the contractor during the progress of work to supplement the bid drawings. Construction drawings will be revised and fresh copies issued to the contractor time to time to incorporate any change to be adopted in the work as per final design to suit any change to be adopted in the work as per final design to suit any condition encountered during the progress of work. Hence "Approved for construction" drawings will be furnished progressively during the progress of the work broadly conforming to construction schedule.
- 1.2 HT/LT main panel, other major equipment, other distribution board drawings and cable route shall be submitted by the contractor for approval of CWC/ consultant before starting fabrication, manufacture.
- 1.3 Details shown either on the drawings or stated in the specification shall prevail upon drawings in case of doubts. However, in case of ambiguity, the more stringent shall be applicable.
- 1.4 **Conformity to IE Act, IE Rules and Standards:** All Electrical works shall be carried out in accordance with the provisions of Indian Electricity Act, 2003 and Indian Electricity Rules, 1956 amended up to date (date of call of tender unless otherwise specified).

### **1.5 EARTHING**

Earthing shall be carried out as per IS rules 3043 code of practice for earthing with latest amendments and as per specification and site requirement.

### **2.0 GUARANTEE**

The tenderer shall guarantee the equipments offered for satisfactory performance for a period of 12 months from the date of commissioning and handing over the installation to the employer against defects arising out of faulty design, material & workmanship. The tenderer should make good all the defects free of costs during the guarantee period and replace or repair the defective equipments/parts free of cost promptly and satisfactorily.

### **3.0 INSPECTION & TESTING**

The purchase representative shall be free to visit the manufacturer's work at all reasonable times to witness and inspect the testing of equipment's. It is the duty of the tenderer to see that all the equipments supplied are tested as per relevant IS/BS specification. The contractor shall furnish three copies of manufacturer test certificate for the routine and type test conducted on the equipments offered. If necessary the contractor shall arrange to conduct all the routine tests at the manufacturer's premises in presence of CWC representative. ON receipt of the equipments/materials at site the tenderer shall offer equipments/materials for inspection of electric engineer and get approved before installation.

### **4.0 PRE-COMMISSIONING TESTS OF EQUIPMENT**

HT/LT switchgear, Transformer LT cables and DG set shall be subjected to the pre-commissioning tests as per approved performance by employer. The pre-commissioning test

report shall be sent to the consultant/CWC for approval for electrical installation/license for release-sanctioned load.

## **5.0 APPROVAL OF DRAWINGS**

The drawings for HT Panels and LT Panels, High Mast, DG set and cable layout shall be offered by the tender for approval of CWC and manufacturing/laying of these items can be taken in the hand only after the approval of the drawings by CWC. The tenderer shall also supply three copies of approved drawings for LT switchgear and transformers (both the dimensional and schematic) along with 03 copies route drawings and earthing positions etc.

**6.0** The contractor shall provide all kind of facilities for inspection of the works by the Engineer of CWC.

**7.0** The electrical work shall conform to CPWD General specifications for external with up to date amendments and for internal electrification works with up to date amendments.

**7.1** The electrical works other than internal and external electrification like DG Set, Substation, High Mast, Fire Detection and Alarm system, Heating, Ventilation & Air Conditioning System (HVAC) and Lifts & Escalators shall conform to latest CPWD General Specifications with up to date amendments.

## **8. Liaisoning/ Approval work with statutory Authorities.**

It will be responsibility of the contractor to do liaisoning work for obtaining necessary approvals/ clearances for electrical load sanction and power supply connection etc. to energizing the terminal, the statutory charges as per the State Electricity Board demand note will be paid by the CWC.

## Approved list of Materials/Equipment/Accessories

### Electrical Items

S.No.	Equipment	IS No.	Approved Makes/ Manufactures
1	LT Panel	Relevant IS	Havells, Neptune, Advance, C&S, Adlec, Geetu Electrical System Pvt. Ltd./ECS, Ghaziabad/Risha Control Engineers Pvt. Ltd./TSR Enterprises, Kolkata
2	MCCB		L&T, Siemens, C&S, GE, Crompton/Schnieder/ABB/Indo-Asian, Havells
3	Floodlight /light fittings	-do-	Bajaj, Crompton, Phillips, Halonix, Havells
4	High Masts		Bajaj, Crompton, Valmont, Phillips
5	XLPE insulated, PVC Sheathed Alu. Conductor armoured/un-armoured power cables (HT & LT)	ISI 7098 (Part I)	M/s Havells , M/s Fort Gloster M/s ICL/Gem Cab, universal, polycab, KEC/KEI, Grandlay
6	Copper conductor cables		Havells/Standard/Finolex/Gem Cab, universal, polycab, Grandlay
7	Cable joints for XLPE LT & HT		Raychem, M-Seal
8	Measuring instruments (Digital)	1248 and 6236 latest	AE, Capital, Neptune/Rishab (L&T)/as per OEM Standard
9	Selector Switch	To relevant ISS	Control Switch Gear/Kaycee/L&T as per OEM standards.
10	Indicating lamps (LED TYPE)/Push Buttons	-do-	Binay/Schneider/L&T/HPL or as per OEM standard
11	Contactors	-do-	L&T/ABB/Schnider/Siemens/Indo-Asian
12	MCB		MDS/ Hager , legrand, ABB/Indo-Asian/Havells
13	Instrument Transformer		AE, Kappa, Alsthom or as per OEM standard
14	Diesel Engine		Cummins/Kirlosker/Kirlosker Green/ KOEL/Caterpillar/Greaves/KEC
15	Alternator		AVK/Stamford/KEC/Crompton Greaves/ KOEL/Kirlosker Green
16	Cable Glands	Relevant IS	Comet/Jainson
17	Cable lugs copper/ Aluminium	Relevant IS	Dowells/Jainson
18	Distribution Boards	Relevant IS	Hager/standard/Legrand/ ABB/Havells
19	Battery	Relevant IS	Exide, Standard Feruk/Cummins /as per OEM standard
20	Transformer	As per latest IS/IS-1180	Kirloskar, Indian Transformer(Gurgaon)/ Kanohar/AMCO/KOTSONS/

			Crompton/MEIL
21	HT Panel		AREVA/Kirloskar/Crompton/ Tricolite/Adlec/ABB/Schnider/GE
22	Vacuum Circuit Breaker		Kirloskar/AREVA/Crompton/GE ABB/Schnider/ Indo-Asian
23	Relay		ABB/Siemens/L&T/English Electric/Areva/as per OEM standard.
24	Capacitors		Neptune Ducattai/ Siemens/Matrix/ABB
25	LED fittings		Crompton/Philips/Bajaj/Orient/Insta Power/Halonix/Havells
26	Ceiling fans/Exhaust Fan		Crompton/Havells/GE/Orient/Bajaj
27	Window Air Conditioner & Split Air Conditioner		Toshiba/ Carrier/ Mitsubishi/ Daikin / Voltas/ Hitachi, / Blue Star/ LG

**Note:**

**Above makes of equipment are approved subject to their meeting the specifications. The contractor, however, shall seek approval of specific make from Engineer In-charge before commencing the work. The decision of Engineer in-charge shall be final and binding on the contractor in this respect.**

Items that are not covered in the above list and are required for execution shall be procured with the approval of Engineer In-charge. The decision of Engineer In-charge shall be final and binding on the contractor in this respect.

**SECTION – XI**  
**(WORK REGISTERS & TESTING PROFORMAS)**



**SITE ORDERS BOOKS**

NAME OF WORK.....

DATE OF COMMENCEMENT/PERIOD FOR COMPLETION

<b>S.NO.</b>	<b>REMAKRS OF THE INSPECTING OFFICER OR CONTRACTOR</b>	<b>ACTON TAKEN AND BY WHOM</b>	<b>REMARKS</b>
1	2	3	4

### HINDRANCE REGISTER

<b>S. No.</b>	<b>Nature Of Hindrance</b>	<b>Items Of Work That Could Not Be Executed Due To This Hindrance</b>	<b>Date Of Start Of Hindrance</b>	<b>Date Of Removal Of Hindrance</b>	<b>Over-Lapping Period If Any</b>	<b>Net Hindrance In Days</b>	<b>Sign Of AE</b>	<b>Weightage Of The Hindrance</b>	<b>Net Effective Days Of Hindrance</b>	<b>Sign Of EE</b>	<b>Remarks Of Reviewing Officer</b>
1	2	3	4	5	6	7	8	9	10	11	12

## MATERIAL AT SITE ACCOUNTS

Region.....

Name of work.....

Name of article.....

Estimate requirements.....

Issue rate.....

S.No.	Date Of Receipt	Received From	Unit	Qty. Received	Progressive received Qty.	Date of issue	To whom issued	Qty. issued	Progressive issued qty.	Balance	Remarks
1	2	3	4	5	6	7	8	9	10	11	12

**CEMENT REGISTER**

<b>Date Of Receipts</b>	<b>Quantity Received</b>	<b>Progressive Recd. Quantity</b>	<b>Date Of Issue</b>	<b>Quantity Issued</b>	<b>Items Of Work For Which Issued</b>	<b>Quantity Returned At The End Of The Day</b>	<b>Total Issue</b>	<b>Progressive Total</b>	<b>Daily Balance At Hand</b>	<b>Contractor's Initial</b>	<b>Site Engineer's Initial</b>	<b>Remarks AE/EE At Periodical Checks</b>
<b>1</b>	<b>2</b>	<b>3</b>	<b>4</b>	<b>5</b>	<b>6</b>	<b>7</b>	<b>8</b>	<b>9</b>	<b>10</b>	<b>11</b>	<b>12</b>	<b>13</b>

**REGISTER FOR RECORDING LEVELS**

<b>S.No.</b>	<b>Changes</b>	<b>Back sight</b>	<b>Intermediate sight</b>	<b>Fore sight</b>	<b>Height of the instrument</b>	<b>Reduced level</b>	<b>Remarks</b>
1	2	3	4	5	6	7	8

**REGISTER FOR SILT CONTENT OF FINE/COARSE SAND**

<b>S.NO</b>	<b>DATE OF TEST</b>	<b>SOURCE OF MATERIAL</b>	<b>HEIGHT OF SILT AFTER SETTING (V-1)</b>	<b>HEIGHT OF SNAD AFTER SETTING (V-2)</b>	<b>%AGE OF SILT CONTENT V1/V2X100</b>	<b>ACCEPTABILITY AS PER SPECIFICATION</b>	<b>SIGN OF SITE ENGINEER WITH DATE</b>	<b>SIGN OF CONTRACTOR WITH DATE</b>	<b>LOCATION ON WHERE SAND USED</b>	<b>REMARKS / ACTION TAKEN</b>
<b>1</b>	<b>2</b>	<b>3</b>	<b>4</b>	<b>5</b>	<b>6</b>	<b>7</b>	<b>8</b>	<b>9</b>	<b>10</b>	<b>11</b>

**REGISTER FOR SLUMP TEST**

<b>S.No.</b>	<b>Date Of Testing</b>	<b>Item Of Work &amp; Location</b>	<b>Vibrator Used Yes/No</b>	<b>Quantity Of Water Added Per Bag Of Cement (Ltrs.)</b>	<b>Height Of Specimen After Removal Of Mould In(mm)</b>	<b>Slump (mm)</b>	<b>Acceptability Of Result Or Action Taken</b>	<b>Sign Of Site Engineer With Date</b>	<b>Sing Of Contractor With Date</b>	<b>Remarks</b>
<b>1</b>	<b>2</b>	<b>3</b>	<b>4</b>	<b>5</b>	<b>6</b>	<b>7</b>	<b>8</b>	<b>9</b>	<b>10</b>	<b>11</b>

**SAMPLE REGISTER**

<b>Material &amp; Identification Mark</b>	<b>No.Of Samples Collected</b>	<b>S.No. Of Sample</b>	<b>Place From Where Sample Collected</b>	<b>Qty. Of Work/Lot Represented By Each Sample</b>	<b>Test</b>	<b>Field/ Lab</b>	<b>Letter No.&amp; Date By Which Sample Sent For Testing</b>	<b>Signature Of Official Drawing Sample</b>	<b>Signature Of The Contractor</b>	<b>Reference For The Results Received</b>	<b>Remarks</b>
<b>1</b>	<b>2</b>	<b>3</b>	<b>4</b>	<b>5</b>	<b>6</b>	<b>7</b>	<b>8</b>	<b>9</b>	<b>10</b>	<b>11</b>	<b>12</b>



**REGISTER FOR PARTICLE SIZE DISTRIBUTION FOR COARSE AGG. & FINE AGG.**

<b>S.No</b>	<b>Date</b>	<b>Weight Of Sample In Gms</b>	<b>Size Of Sieves</b>	<b>Weight Retained On Each Sieve</b>	<b>%Age Of Weight Retained</b>	<b>Cumulative %Age Of Weight Retained</b>	<b>%Age Of Weight Passing</b>	<b>Specified %Age Of Weight Passing</b>	<b>Sign Of Contractor With Date</b>	<b>Sign Of Site Engineer With Date</b>	<b>Remarks/ Action Taken</b>
<b>1</b>	<b>2</b>	<b>3</b>	<b>4</b>	<b>5</b>	<b>6</b>	<b>7</b>	<b>8</b>	<b>9</b>	<b>10</b>	<b>11</b>	<b>12</b>

**NOTE: SIZE OF SEIVE SHOULD BE AS PER CPWD MANUAL/BIS SPECIFICATIONS.**

**PHYSICAL WEIGHMENT REGISTER**

**Tor steel bars/truss members/other misc. items**

<b>S. No.</b>	<b>Date</b>	<b>Description of sample</b>	<b>Actual weight per unit</b>	<b>Theoretical weight per unit</b>	<b>Actual thickness outerdia</b>	<b>Theoretical thickness Outer dia</b>	<b>Remarks accepted/rejected</b>	<b>Initials of Site Engineer</b>	<b>Contractor Sign.</b>
<b>1</b>	<b>2</b>	<b>3</b>	<b>4</b>	<b>5</b>	<b>6</b>	<b>7</b>	<b>8</b>	<b>9</b>	<b>10</b>

### CUBE TEST

S.No.	Date Of Collection	Grade Of Mix	Mark Of Specificaton	7 Days Test Result				28 Days Test Result				Required Specified Strength	Approx.Qty.Repre sented By Specimen	Item Of Work From Where The Sample Is	Sign Of Site Engineer With Date	Contractor/Contr actor's Rep. With Sign
				DATE OF TESTING	LOAD IN kN	COMPRESSIVE STRENGTH(kN /mm2)	AVERAGE COMPRESSIVE STRENGTH(kN /mm2)	DATE OF TESTING	LOAD IN kN	COMPRESSIVE STRENGTH(kN /mm2)	AVERAGE COMPRESSIVE STRENGTH(kN /mm2)					
1	2	3	4	5	6	7	8	9	10	11	12	13	14	15	16	17

### Density Test by Core Cutter Method

MDD as per lab test W5.....

Sl. No	Location (C.H.) / Area Represented by the Test	Core Cutter Nos.	Weight of Core Cutter + Weight of Soil (in gram) (W1)	Weight of Empty Core cutter (in gram) (W2)	Weight of Wet Soil (in gram) W = W1-W2	Volume of Core Cutter (in CC) V	Bulk Density (gram/cc) W3= W/V	Moisture Content of compaction layers (M)	Dry Density gram/cc W4 = W3/ (1+M)	Degree of compaction W4/W5	Acceptability limit	Sign. of Site Engineer with date	Contractor / contractor's representative Signature with Name & date
1	2	3	4	5	6	7	8	9	10	11	12	13	14

**TEST FOR THICKNESS AND DENSITY OF THE COMPACTED LAYER (BY SAND REPLACEMENT METHOD)**

for Asphalt Concrete / Bitumen Macadam / CC Pavement

Lab Test Density in gms/CC .....

Sl. No	Date of Test	Qty. represented by the test	Location of holes	Thickness of Layer		Weight of materials removed from the carpet Hole	Initial weight of sand taken in Cylinder	Weight of sand filling in cone of cylinder	Weight of sand remaining in cylinder	Predetermined bulk density of sand	Density = $\frac{A.d. W}{W1+W2}$	Remarks / Acceptability	Sign. Of Site Engineer	Contractor / contractor's representative Signature with Name & date	Action Taken
				Individual (mm)	Average (mm)										
1	2	3	4	5	6	A gm	W gm	WI gm	W2 gm	d gm/CC	gm/CC	13	14	15	16

## DENSITY TEST REGISTER FOR SOIL ---- BY SAND REPLACEMENT METHOD

Wt. of Standard Sand in grams/CC (W6) = .....

Unit Lab Test MDD in gms/cc (W10) = .....

Sl. No	Date of Test	Qty. represented by the test	Location of holes	Thickness of Layer (mm)		Wt. of Material from the hole	Moisture Content %age	Initial weight of sand taken in the Cylinder before filling in hole in gms	Wt. of sand after filling in hole in gms	Wt. of sand in hole & cone in gms	Wt. of sand in cone in gms	Wt. of sand in hole in gms	Volume of hole in CC	Bulk Density in gms/CC	Dry Density in gms/CC	Degree of compaction	Remarks / Acceptability	Sign. Of Site Engineer with date	Contractor / contractor's representative Signature with Name & date	Action Taken
1	2	3	4	5 Individual	6 Average	7 (W) gms	8 (Y)	9 (W1)	10 (W2)	11 (W3)= W1-W2	12 (W4)	13 W5 = (W3-W4)	14 (W7)= W5/W6	15 (W8)=W/W7	16 (W9)= W8/Y	17 W9/W10 x100	18 W9/W10 x100	19	20	21

**TEST OF THE BRICK / BRICK TILES FOR COMPRESSIVE STRENGTH**

<b>Sl. No</b>	<b>Date of collection of sample</b>	<b>Date of testing</b>	<b>Wt. (in Kg)</b>	<b>No. of Specimen</b>	<b>Size in cm/Area in cm<sup>2</sup></b>	<b>Compressive Strength obtained for individual</b>	<b>Average Strength in Kg/Cm<sup>2</sup></b>	<b>Specified Compressive Strength in</b>	<b>Acceptability</b>	<b>Sign. Of Site Engineer with</b>	<b>Contractor / contractor's representative Signature with</b>	<b>Action Taken / Remark</b>
<b>1</b>	<b>2</b>	<b>3</b>	<b>4</b>	<b>5</b>	<b>6</b>	<b>7</b>	<b>8</b>	<b>9</b>	<b>10</b>	<b>11</b>	<b>12</b>	<b>13</b>

### ROAD ROLLER REGISTER

S.No.	Date	Period		Hours	Description of item rolled	Qty. of area rolled	Theoretical Qty./area to be rolled.	Signature of Site Engineer	Signature of contractor	Remarks
		From	To							
1	2	3	4	5	6	7	8	9	10	11



**REGISTER FOR DISMANTLED MATERIAL**

Name of work.....

Name of Division.....

S.No.	Date of Receipt	Ref. to No. & page of MB	Full particulars of material giving size etc. if any	Opening balance	Qty. Recd.	Total	Ref.to its disposal whether by write off sale of transfer to other works	Qty. issued or disposed off	Closing balance	Dated initial of the site Engineer	Date of verification of balance by whom verified	Remarks
1	2	3	4	5	6	7	8	9	10	11	12	13

**REGISTER FOR BULKING OF SAND**

<b>S.NO.</b>	<b>Date Of Testing</b>	<b>Particulars of work represented by sample</b>	<b>Qty.of lot/qty.of material</b>	<b>Height of dry sand (X)</b>	<b>Height of sand after mixing water (Y)</b>	<b>Bulking of sand (X/Y-1)x100</b>	<b>Action taken for bulkage</b>	<b>Signature of Site Engineer</b>	<b>Signature of contractor</b>	<b>REMARKS</b>
<b>1</b>	<b>2</b>	<b>3</b>	<b>4</b>	<b>5</b>	<b>6</b>	<b>7</b>	<b>8</b>	<b>9</b>	<b>10</b>	<b>11</b>

## BILL PROFORMA ON LETTER HEAD OF CONTRACTOR

Name of work:-

Agreement No:-

Date of preparation of bill:-

Date of start:-

Due date of completion:-

Details of Service Provider	Details of Service Receiver
Name:	Name:
Address:	Address:
City:	City:
State:	State:
State Code:	State Code:
GSTIN:	GSTIN (if Registered):
PAN NO.:	

Invoice Serial No.: \_\_\_\_\_

HSN

Date of Invoice: \_\_\_\_\_

Description of Services:

S.No	Item No.	Description of Items	Unit	Qty as per Agt.	Rate as per Agt.	Qty as per Pre. Bill	Qty as per this Bill	Cumulative Qty.	Amt. as per Previous Bill	Amt. as per this Bill	Cumulative Amt.
1											
2											
3											
						Total					
						Grand Total					

Total Invoice Value (in figure)

Total Invoice Value (in Words)

Amount of Tax Subject to reverse Charge:  
NIL

<b>Total Taxable Value</b>	
	<b>Rate</b>
CGST	%
SGST	%
IGST*	%
<b>Total Invoice Amt.</b>	

**Signature:** \_\_\_\_\_

**Name of the Signatory:** \_\_\_\_\_

**Designation/Status:** \_\_\_\_\_

**SECTION – XII**  
**(LIST OF MANDATORY TEST)**

### LIST OF MANDATORY TESTS

S. No.	Description of Material	Test	Reference of IS Code / Specification for testing	Field / Laboratory test	Frequency of testing
1	<b>Cement (Approved brand)</b>	Physical & chemical properties	IS : 4031	Lab	Initial Test-01 test for each brand of cement. Subsequently, 01 test for 200 MT or part thereof for each brand. Cement should be of approved brand and each lot should be accompanied by manufacturer's test certificates
2	<b>Reinforcement steel (Approved brand)</b>	Physical & chemical properties	IS :1786	Lab	Initial Test-01 test for each brand and each dia of reinforcement steel , Subsequently - One test for every 25/35/45 MT or part thereof (As specified in Special condition of Contract Para 6.7) Reinforcement Steel should be of approved brand and each lot should be accompanied by manufacturer's test certificates
3	<b>Water</b>	PH value, chlorides, sulphates, alkalinity test, acidity test, suspended matter, organic matter and inorganic matter	IS:3025	Lab	Initial Test- Source approval at commencement of work and Subsequently- every six months or change of source.

4	<b>Coarse Aggregate - Building works</b>	Gradation	IS 2386 - I	Field / Lab	Minimum one test for every 50 cum or part thereof.
		Deleterious material	IS 2386 - II	Field / Lab	
		Specific Gravity	IS 2386 - III	Field / Lab	
		Crushing value	IS 2386 - IV	Field / Lab	
		impact value	IS 2386 - IV	Field / Lab	
		10% fine value	IS 2386 - IV	Field / Lab	
5	<b>Fine Aggregate- Building works</b>	Organic impurities	Appendix 'A' of chapter 3, CPWD Specifications	Field	Minimum one test for every 50 cum or part thereof.
		Silt content	Appendix 'C' of chapter 3, CPWD Specifications	Field	
		Bulking of Sand	Appendix 'D' of chapter 3, CPWD Specifications	Field	
		Gradation	Appendix 'B' of chapter 3, CPWD Specifications	Field / Lab	
6	<b>Coarse Aggregate - Road , Pavement works</b>	Gradation	IS 2386 - I	Field / Lab	One test for every day's work.
		Flakiness and Elongation Index	IS 2386 - I	Field / Lab	Once for each source of supply and subsequently on monthly basis.
		Deleterious material	IS 2386 - II	Lab	Once for each source of supply and subsequently on monthly basis.
		Water Absorption	IS 2386 - III	Lab	Once for each source of supply and subsequently on monthly basis.

		Los Angeles Abrasion Value/Aggregate Impact value	IS 2386 - IV	Lab	Once for each source of supply and subsequently on monthly basis
		Soundness	IS 2386 - V	Lab	Before approving the aggregates and every month subsequently.
		Alkali aggregate reactivity	IS 2386 - VII, IS:456	Lab	Before approving the aggregates and every month subsequently.
<b>7</b>	<b>Fine Aggregate - Road , Pavement works</b>	Gradation	IS 2386 - I	Field / Lab	One test for every day's work.
		Deleterious material	IS 2386 - II	Lab	Once for each source of supply and subsequently on monthly basis.
		Water Absorption	IS 2386 - III	Lab	Once for each source of supply and subsequently on monthly basis.
		Silt Content	Appendix 'C' of chapter 3 ,CPWD Specifications	Field	Once for each source of supply and subsequently on monthly basis.
<b>8</b>	<b>Slump Test - Building Works</b>		Appendix 'D' of Chapter 4, CPWD Specifications	Field	Minimum one test for every 20 cum of concrete or part thereof
<b>9</b>	<b>Slump Test - Pavement Works</b>		IS 1199	Field	One test per each dumper load at both Batching plant site and paving site initially when work starts. Subsequently, sampling may be done from alternate dumper.
<b>10</b>	<b>Cube Test</b>				
<b>(i)</b>	<b>Reinforced Cement Concrete - Building works</b>	7 days and 28 days Compressive strength	IS 516	Lab	One sample of six cubes for every 50 cum or part thereof

(ii)	<b>Pavement Quality Concrete (PQC) - Pavement Work</b>	Compressive strength, flexure strength	IS 516	Lab	2 cube set samples and 2 beam set samples per 150 cum or part thereof for each day production.
<b>11</b>	<b>Earthwork</b>				
	<b>Control test on borrow pits.</b>	Gradation	IS 2720 -IV	Lab	One or two tests per 8000 cum
		Plasticity	IS: 2720-V	Lab	
		Proctor test	IS 2720-VIII	Lab	
		Maximum dry density / OMC	IS 2720-VIII	Lab	
		Deleterious Content		Lab	As and when required by Engineer
		Moisture Content	IS: 2720-II	Lab	250 cum.
	<b>Embankment under (OMC conditions)</b>		IS: 2720-XXVIII	Field	250 cum.
			IS: 2720-II	Field	250 cum.
<b>12</b>	<b>Granular Sub base</b>				
			IS 2386- I	Field / Lab	Minimum 01 test per source and additional test after every 1000 cum
			IS 2386- III	Lab	Minimum 01 test per source and additional test as required by Engineer
			IS 5640	Lab	As required by Engineer
			IS 2386- IV	Lab	Minimum 01 test per source and additional test after every 2000 cum
		Atterberg's limit	IS 2720-V	Lab	Minimum 01 test per source and additional test after every 1000 cum
		Maximum dry density /OMC	IS 2720-VIII	Lab	Minimum 01 test per source and additional test as required by Engineer
		Moisture content prior to compaction	IS 2720-II	Field	Minimum 01 test every 400 cum
		Field Density	IS 2720-	Field	one test per 2000 Sqm



			XXVIII		or part thereof
		Deleterious material	IS: 2720-XXVII	Lab	Minimum 01 test per source and additional test as required by Engineer
		CBR	IS 2720-XVI	Lab	Minimum 01 test per source and additional test as required by Engineer
<b>13</b>	<b>Water Bound Macadam</b>				
		Gradation	IS 2386- I	Field / Lab	Minimum 01 test per source and additional test after every 500 cum
		Aggregate Value or Aggregate Impact Value	IS 2386- IV or IS5640	Lab	Minimum 01 test per source and additional test after every 500 cum
		Combined Flakiness	IS 2386- I	Lab	Minimum 01 test per source and additional test after every 500 cum
		Lost Angles	IS 2386-IV	Lab	Minimum 01 test per source and additional test after every 500 cum or part thereof
<b>14</b>	<b>Wet Mix Macadam</b>	Gradation	IS 2386 - I	Field / Lab	Minimum 01 test per source and additional test after every 500 cum
		Water Absorption	IS 2386-III	Lab	Minimum 01 test per source and additional test as required by Engineer
		Soundness (if WA > 2.0%)	IS 2386-V	Lab	As required by Engineer
		Atterberg's limit of portion of aggregate passing 425 micron sieve	IS 2720 - V	Lab	Minimum 01 test per source and additional test after every 500 cum or part thereof
		Aggregate Impact value	IS 2386- IV or IS 5640	Lab	Minimum 01 test per source and additional test after every 500 cum
		Maximum Dry Density / OMC	IS 2720 - VIII	Lab	Minimum 01 test per source and additional test as required by Engineer

		Combined Flakiness and Elongation Indices	IS 2386 - I	Lab	Minimum 01 test per source and additional test after every 500 cum
		Moisture content	IS 2720-II	Field	Minimum 03 tests per day
		Field Density	IS 2720 - XXVIII	Field	One set of three test per 2000 sqm or part thereof
<b>15</b>	<b>Bitumen</b>				
		As prescribed in IS 73	As prescribed in IS 73	Lab	As required by the Engineer-in charge
<b>16</b>	<b>Dense Bituminous Macadam / Bituminous Concrete</b>				
		Quality of Binder	IS 73	Lab	As required
		Los Angeles Abrasion Value/ Aggregate impact value	IS 2386-IV	Lab	100 cum.
		Stripping Value	IS 6241	Lab	100 cum.
		Water Absorption	IS 2386-III	Lab	100 cum.
		Flakiness Index	IS 2386-I	Lab	One test for 100 cum.
		Sieve Analysis for filler	IS 2386- I	Lab	One test for each consignment subject to minimum one test per 5 cum.
		Mix Grading	IS 2386-I	Lab	One set of test on individual constituent and mixed aggregates from dryer of each 100 tonnes of mixed subject to a minimum of two sets per plant per day.
		Stability of Mix	ASTM: D-1559	Lab	Three marshall specimen per 100 tonnes of mix, subject to a minimum of two sets being tested per plant per day.
		Binder Content		Field	Minimum 2 tests per day
		Thickness, Density of compacted layer	Appendix 'B' of CPWD Specification	Field	One test of 3 samples per 500 sqm.
<b>17</b>	<b>Brick work / brick tiles / sewer brick/Burnt clay perforated building Bricks</b>				

		Dimension	Appendix A, B, C & D of Chapter 6 of CPWD Specifications	Lab	Minimum one test for every 50000 bricks or part thereof
		Compressive strength		Lab	
		Water Absorption		Lab	
		Efflorescence		Lab	
<b>18</b>	<b>Stone work</b>				
		Water absorption	IS 1124	Lab	Minimum one test for every 200 sqm / 100 cum or part thereof
		Transverse Strength	IS 1121 - II		
		Resistance to wear	IS 1706		
		Durability	IS 1126		
<b>19</b>	<b>Marble</b>				
		Moisture absorption	IS 1124	Lab	Minimum one test for every 100 sqm or part thereof
		Hardness test	Mho's Scale		
		Specific Gravity	IS 1122		
<b>20</b>	<b>Granite</b>				
		Moisture	IS 1124	Lab	Minimum one test for every 100 sqm or part thereof
		Specific Gravity	IS 1122		
<b>21</b>	<b>Structural Steel (other than PEB)</b>				
		Tensile strength	IS 1599	Lab	Minimum one test for every 20 tonnes or part thereof per source and also manufacturer's test certificates for each consignment should be accompanied.
		Bend Test			
<b>22</b>	<b>Steel Tubular pipes</b>				
		Tensile test	IS 1608	Lab	Minimum one test for every 8 tonne or part thereof per source and also manufacturer's test certificates for each consignment should be accompanied.
		Bend Test	IS 2329		
		Flattening Test	IS 2328		
<b>23</b>	<b>M 50 Grade Cement Concrete Paver Blocks</b>				
(i)	<b>M-50 Grade Pre-Cast Concrete</b>	Compressive Strength	As per IS code 15658	Field / Lab	Minimum one test for every 50000 bricks or

	<b>Paving Blocks</b>	Water absorption	As per IS code 15658	Field / Lab	part thereof
		Dimensions	As per IS code 15658	Field / Lab	
<b>(ii)</b>	<b>Sand for Bedding Layer</b>				
		Percentage of Deleterious material	IS 2386	Lab	Minimum one test for every 50 cum or part thereof
		Particle Size Distribution	As per Technical specification	Field / Lab	
		Silt Content	As per Appendix 'C' of Chapter 3 of CPWD Specifications	Field	
		Moisture Content	IS 2720	Field	
<b>(iii)</b>	<b>Sand for Joint Filling</b>	Particle Size Distribution	As per Technical specification	Field / Lab	Minimum one test for every 50 cum or part thereof.
<b>Note:-</b>	<b>For items not covered above may be dealt with as per the technical specifications in the contract / mandatory tests will be carried out as per CPWD specifications.</b>				

**ANNEXURE TO SCHEDULE 'A'**  
**(Schedule of Quantity)**

SLNo	Description	Qty	Unit	Rate	Amount
<b>1</b>	<b>EARTH WORK</b>				
1.1	Supplying and filling in plinth with sand under floors, including watering, ramming, consolidating and dressing complete.	39.88	cum	917.75	36600.00
<b>2</b>	<b>CONCRETE WORK</b>				
2.1	Providing and laying in position cement concrete of specified grade excluding the cost of centering and shuttering - All work up to plinth level :				
2.1.1	1:1½:3 (1 Cement: 1½ coarse sand (zone-III) : 3 graded stone aggregate 20 mm nominal size).	92.87	cum	5924.65	550222.00
2.1.2	1:2:4 (1 cement : 2 coarse sand (zone-III) : 4 graded stone aggregate 20 mm nominal size).	0.45	cum	5481.95	2467.00
2.1.3	1:4:8 (1 Cement : 4 coarse sand (zone-III) : 8 graded stone aggregate 40 mm nominal size)	25.25	cum	4478.15	113073.00
2.2	Making plinth protection 50mm thick of cement concrete 1:3:6 (1 cement : 3 coarse sand : 6 graded stone aggregate 20 mm nominal size) over 75mm thick bed of dry brick ballast 40 mm nominal size, well rammed and consolidated and grouted with fine sand, including necessary excavation, levelling & dressing & finishing the top smooth.	315.00	sqm	450.35	141860.00
<b>3</b>	<b>REINFORCED CEMENT CONCRETE</b>				
3.1	Providing and laying in position specified grade of reinforced cement concrete, excluding the cost of centering, shuttering, finishing and reinforcement - All work up to plinth level :				
3.1.1	1:1.5:3 (1 cement : 1.5 coarse sand (zone-III): 3 graded stone aggregate 20 mm nominal size).	39.41	cum	6215.35	244947.00
3.2	Reinforced cement concrete work in walls (any thickness), including attached pilasters, buttresses, plinth and string courses, fillets, columns, pillars, piers, abutments, posts and struts etc. above plinth level up to floor five level, excluding cost of centering, shuttering, finishing and reinforcement :				
3.2.1	1:1.5:3 (1 cement : 1.5 coarse sand(zone-III) : 3 graded stone aggregate 20 mm nominal size).	9.65	cum	7145.80	68957.00
3.3	Reinforced cement concrete work in beams, suspended floors, roofs having slope up to 15° landings, balconies, shelves, chajjas, lintels, bands, plain window sills, staircases and spiral stair cases above plinth level up to floor five level, excluding the cost of centering, shuttering, finishing and reinforcement, with 1:1.5:3 (1 cement : 1.5 coarse sand (zone-III) : 3 graded stone aggregate 20 mm nominal size).	16.44	cum	7390.80	121505.00
3.4	Centering and shuttering including strutting, propping etc. and removal of form for:				
3.4.1	Foundations, footings, bases of columns, etc. for mass concrete	35.84	sqm	193.95	6951.00

3.4.2	Walls (any thickness) including attached pilasters, buttresses, plinth and string courses etc.	82.64	sqm	378.60	31288.00
3.4.3	Lintels, beams, plinth beams, girders, bressumers and cantilevers	218.69	sqm	342.90	74989.00
3.4.4	Columns, Pillars, Piers, Abutments, Posts and Struts	110.52	sqm	467.85	51707.00
3.5	Steel reinforcement for R.C.C. work including straightening, cutting, bending, placing in position and binding all complete upto plinth level.				
3.5.1	Thermo-Mechanically Treated bars of grade Fe-500D or more.	8514.19	Kg	56.60	481903.00
<b>4</b>	<b>STONE WORK</b>				
4.1	Random rubble masonry with hard stone in foundation and plinth including levelling up with cement concrete 1:6:12 (1 cement : 6 coarse sand : 12 graded stone aggregate 20 mm nominal size) upto plinth level with :				
4.1.1	Cement mortar 1:6 (1 cement : 6 coarse sand)	6.22	cum	3965.85	24668.00
<b>5</b>	<b>WOOD AND P.V.C. WORK</b>				
5.1	Providing and fixing ISI marked oxidised M.S. sliding door bolts with nuts and screws etc. complete :				
5.1.1	250x16 mm	30	each	142.05	4262.00
<b>6</b>	<b>STEEL WORK</b>				
6.1	Structural steel work in single section, fixed with or without connecting plate, including cutting, hoisting, fixing in position and applying a priming coat of approved steel primer all complete.	530.82	kg	58.45	31026.00
6.2	Providing and fixing mild steel round holding down bolts with nuts and washer plates complete.	11.20	kg	68.00	762.00
<b>7</b>	<b>ROOFING</b>				
7.1	Providing and fixing precoated galvanised iron profile sheets (size, shape and pitch of corrugation as approved by Engineer-in-charge) 0.50 mm (+ 0.05 %) total coated thickness with zinc coating 120 grams per sqm as per IS: 277, in 240 mpa steel grade, 5-7 microns epoxy primer on both side of the sheet and polyester top coat 15-18 microns. Sheet should have protective guard film of 25 microns minimum to avoid scratches during transportation and should be supplied in single length upto 12 metre or as desired by Engineer- in-charge. The sheet shall be fixed using self drilling /self tapping screws of size (5.5x 55 mm) with EPDM seal, complete upto any pitch in horizontal/ vertical or curved surfaces, excluding the cost of purlins, rafters and trusses and including cutting to size and shape wherever required.	63.60	sqm	550.40	35005.00
7.2	Providing and fixing precoated galvanised steel sheet roofing accessories 0.50 mm (+ 0.05 %) total coated thickness, Zinc coating 120 grams per sqm as per IS: 277, in 240 mpa steel grade, 5-7 microns epoxy primer on both side of the sheet and polyester top coat 15-18 microns using self drilling/ self tapping screws complete :				
7.2.1	Ridges plain (500 - 600mm)	2.00	metre	360.45	721.00
7.2.2	Flashings /Aprons (upto 600mm)	31.20	metre	332.80	10383.00
<b>8</b>	<b>FINISHING</b>				
8.1	15 mm cement plaster on the rough side of single or half brick wall of mix :				

8.1.1	1:6 (1 cement: 6 fine sand)	234.35	sqm	185.20	43402.00
8.2	20 mm cement plaster of mix :				
8.2.1	1:6 (1 cement: 6 fine sand)	8.81	sqm	220.60	1943.00
8.3	12 mm cement plaster of mix :				
8.3.1	1:4 (1 cement: 4 coarse sand)	213.63	sqm	180.85	38635.00
8.4	6 mm cement plaster of mix :				
8.4.1	1:3 (1 cement : 3 fine sand)	145.32	sqm	143.80	20897.00
8.5	White washing with lime to give an even shade :				
8.5.1	New work (three or more coats)	285.01	sqm	17.25	4916.00
8.6	Applying one coat of water thinnable cement primer of approved brand and manufacture on wall surface :				
8.6.1	Water thinnable cement primer	308.29	sqm	36.95	11391.00
8.7	Finishing walls with Acrylic Smooth exterior paint of required shade :				
8.7.1	New work (Two or more coat applied @ 1.67 ltr/10 sqm over and including priming coat of exterior primer applied @ 2.20 kg/10 sqm)	308.29	sqm	96.05	29611.00
8.8	Painting with synthetic enamel paint of approved brand and manufacture to give an even shade :				
8.8.1	Two or more coats on new work	21.06	sqm	78.40	1651.00
<b>9</b>	<b>REPAIRS TO BUILDINGS</b>				
9.1	Painting with synthetic enamel paint of approved brand and manufacture of required colour to give an even shade :				
9.1.1	One or more coats on old work	69.31	sqm	51.30	3556.00
<b>10</b>	<b>DISMANTLING &amp; DEMOLISHING</b>				
10.1	Demolishing cement concrete manually/ by mechanical means including disposal of material within 50 metres lead as per direction of Engineer - in - charge.				
10.1.1	Nominal concrete 1:3:6 or richer mix (i/c equivalent design mix)	19.09	cum	997.05	19034.00
10.2	Demolishing R.C.C. work manually/ by mechanical means including stacking of steel bars and disposal of unserviceable material within 50 metres lead as per direction of Engineer - in - charge.	16.70	cum	1454.55	24291.00
10.3	Demolishing brick work manually/ by mechanical means including stacking of serviceable material and disposal of unserviceable material within 50 metres lead as per direction of Engineer-in-charge.				
10.3.1	In cement mortar	118.31	cum	842.75	99706.00
10.4	Demolishing stone rubble masonry manually/ by mechanical means including stacking of serviceable material and disposal of unserviceable material within 50 metres lead as per direction of Engineer-in-charge :				
10.4.1	In cement mortar	6.22	cum	1005.70	6255.00
10.5	Taking out doors, windows and clerestory window shutters (steel or wood) including stacking within 50 metres lead :				
10.5.1	Of area 3 sq. metres and below	8.00	each	61.25	490.00
10.5.2	Of area beyond 3 sq. metres	15.00	each	81.00	1215.00
10.6	Dismantling roofing including ridges, hips, valleys and gutters etc., and stacking the material within 50 metres lead of:				
10.6.1	G.S. Sheet	194.40	sqm	70.10	13627.00

10.7	Dismantling manually/ by mechanical means including stacking of serviceable material and disposal of unserviceable material within 50 metres lead as per direction of Engineer-in-charge :				
10.7.1	Water bound macadam road	360.83	sqm	90.50	32655.00
<b>11</b>	<b>ROAD WORK</b>				
11.1	Supplying and stacking at site.				
11.1.1	90 mm to 45 mm size stone aggregate	95.69	cum	1336.05	127847.00
11.1.2	63 mm to 45 mm size stone aggregate	35.98	cum	1449.30	52146.00
11.1.3	Stone screening 13.2 mm nominal size (Type A)	32.03	cum	1505.60	48224.00
11.2	Laying, spreading and compacting stone aggregate of specified sizes to WBM specifications in uniform thickness, hand picking, rolling with 3 wheeled road / vibratory roller 8-10 tonne capacity in stages to proper grade and camber, applying and brooming requisite type of screening / binding material to fill up interstices of coarse aggregate, watering and compacting to the required density .	108.74	cum	449.10	48835.00
<b>12</b>	<b>PILE WORK</b>				
12.1	Boring with hydraulic piling rigs with power units, Providing and installing cast in situ single under reamed piles of specified diameter and length below pile cap in M-25 cement concrete, to carry a safe working load not less than specified, excluding the cost of steel reinforcement but including the cost of boring with bentonite solution and the length of the pile to be embedded in pile cap etc. all complete. (Length of pile for payment shall be measured upto to the bottom of pile cap) :				
12.1.1	550 mm dia piles	70.40	metre	3199.85	225269.00
<b>13</b>	<b>NS-Road Works</b>				
13.1	Consolidation of sub grade with power road roller of 8 to 12 tonne capacity i/c making good the undulations etc. with earth or quarry spoils etc and rerolling the sub grade.	360.83	Sqm	2.30	830.00
<b>14</b>	<b>NS Items</b>				
14.1	Disposal of surplus excavated earth/soil ( as received from excavation of foundation trenches, drains/cables/pipes trenches, sub-grade of roads & floors, chamber pits & the like but excluding the earth soil/ as received from excavation over areas exceeding 30 cm in depth 1.5m in width as well as 10 sqm. On plan and surface dressing away from CWC premises in all leads, & lifts including transportation by Mechanical transport, loading and unloading as directed by Engineer in charge.	119.00	cum	155.80	18540.00
14.2	Earth work in excavation by mechanical means (Hydraulic excavator)/ manual means over areas(exceeding 30 cm. In depth 1.5 m in width as well as 10 sqm. On plan ) i/c disposal of excavated earth away from CWC premises in all leads and lifts and in all kinds of soils i/c transportation by Mechanical transport, loading and unloading as per directions of Engineer in charges.	62.06	Cum	184.95	11478.00



14.3	Supply & filling selected earth obtained from approved source (excluding rock) in layers not exceeding 20 cm. in depth breaking clods, watering and consolidation of each layer by half tonne roller or by using wooden or steel hammer and rolling every third and top most layer with power roller of minimum 8 tonnes and dressing up in embankments or roads plinth filling or filling of ground depressions within the campus, i/c of all leads and lifts (no royalty or seignorage shall be paid by the CWC to contractor.	123.32	cum	473.20	58355.00
14.4	Cutting of groove 6 X 20 mm size in the finished floor and filling with sealing compound as approved by Engineer-in-charge complete	307.46	metre	49.10	15096.00
14.5	Providing and spreading non-metallic floor hardener minimum @ 4.5kg/sqm in floor concrete (as per manufactures specifications and approved by Engineer-in-charge). Nothing extra shall be payable if manufacturer specifies extra quantity.	415.27	sqm	67.00	27823.00
<b>15</b>	<b>MR Items</b>				
15.1	Providing and laying over existing bed of concrete, WBM etc. 200 micron thick black polyethene sheet virgin, UV Resistant approved specifications as per IS 2508:1984 including all labour complete as per directions of engineer-in-charge	30.86	sqm	33.50	1034.00
15.2	Solid Cement block masonry in cement mortar using high density good quality solid CC Block should be mechanically compacted and water cured for (Mix ratio one part by volume of cement to nine part by volume of combined aggregate before mixing) having average compressive strength of 3.5N/Sqmm. in foundation and in plinth with cement mortar 1:4 (1 cement: 4 coarse sand) (400*200*200 size)	4.95	Cum	5009.00	24795.00
15.3	Solid Cement block masonry in cement mortar using high density good quality solid CC Block should be mechanically compacted and water cured for (Mix ratio one part by volume of cement to nine part by volume of combined aggregate before mixing) having average compressive strength of 3.5N/Sqmm. in superstructure upto floor V level with cement mortar 1:6 (1 cement: 6 coarse sand) (400*200*200 size)	70.05	Cum	5529.00	387307.00
15.4	Refixing of Dismantled V4 Ventilators mesh frame embedded in c.conc. blocks of size 75x75x125mm of c.conc. 1:2:4 (1 cement: 2 coarse sand: 4 graded stone aggregate 20 mm nominal size) Note: payment for c.con. blocks, bolts, shall be paid under relevant items, payment for m.s. frame shall be paid on area basis of outer to outer dimension of frame.	9.90	Sqm	863.00	8544.00

15.5	Drilling suitable holes in reinforced or plain cement concrete with power driven drill machine to a minimum depth of 100mm upto 200mm in RCC beams, lintels, columns and slabs to introduce steel bars for sunshades/balconies including fixing the steel bars in position using epoxy resin anchor grout of approved make but excluding the cost of reinforcement, all complete as per direction of Engineer-In- Charge.  Upto and including 16mm dia.				
a.)	Upto and including 16mm dia.	276	each	108.02	29814.00
b.)	20mm dia	96	each	120.35	11554.00
15.6	ReFixing precoated galvanised iron profile sheets taken out during dismantling from godowns The sheet shall be fixed using self drilling /self tapping screws of size (5.5x 55 mm) with EPDM seal, complete upto any pitch in horizontal/ vertical or curved surfaces, excluding the cost of purlins, rafters and trusses and including cutting to size and shape wherever required.	159.00	Sqm	108.20	17204.00
15.7	Re fixing precoated galvanised steel sheet roofing accessories 0.50 mm (+ 0.05 %) taken out during dismantling from godowns using self drilling/ self tapping screws complete.	5.00	Mtr	79.00	395.00
15.8	Providing of 40x6mm M.S flat iron section to fix flashing with wall. Fixing of flat section to be done with anchor bolts as per the directions of Engineer in charge. Fixing of anchor bolts to be paid separately.	3.30	Mtr	133.00	439.00
15.9	Providing and fixing anchor bolts of dimension 10x160mm, including drilling of hole in flat section, concrete/masonry, etc. As per directions of Engineer-in-charge to fix flashings to outer wall. etc. as per direction of Engineer-in-charge.	35.00	No.s	131.00	4585.00
15.10	Carrying out repair works in dismantled doors including but not limited to removing of dents, straightening any and all members of doors which are in bent condition and refixing the doors in its original place.	119.31	Sqm	678.00	80893.00
	<b>Total</b>				<b>3587578.00</b>
	<b>Credit items</b>				
	Reinforcement from Old Beams	751.5	Kg	12.00	8942.40
	Credit for stones from RR masonry	4.98	cum	800.00	3984.00
	Credit from Bricks by demolishing Walls	43018	No.s	2.00	86036.00
	Credit for Dismantled WBM	82.99	cum	1060.00	87970.00
	Total credit items				<b>186932.40</b>

**PRICE BID FORMAT**

**CENTRAL WAREHOUSING CORPORATION**

(A Govt. of India Undertaking)

Regional Office Bangalore

---

**Name of work:** -Major repairs and strengthening to Gable walls of Godown No. 2A to avoid differential settlement and remedial measures including Piling at CW gadag-II,( Karnataka)

**ESTIMATED COST FOR SCHEDULE OF QUANTITIES**

**For all Items of Tender BOQs per Table 1(Annexure of Schedule-A)is Rs. 35,87,578/-**(Rupees Thirty Five lakh Eighty seven thousand five hundred seventy eight Only

a) I / We hereby tender our rates as ..... % (..... Percent) **ABOVE** the rates entered in the schedule of quantities.

**OR**

b) I / We hereby tender our rates as ..... % (..... Percent) **BELOW** the rates entered in the schedule of quantities.

**NOTE:** The tenderers should quote their percentage appropriately either at (a) or at (b) mentioned above as the case may be in separate excel sheet (price bid) and digitally signed.

**Rates are not to be quoted here in technical bid.**

**SUPERINTENDING ENGINEER**

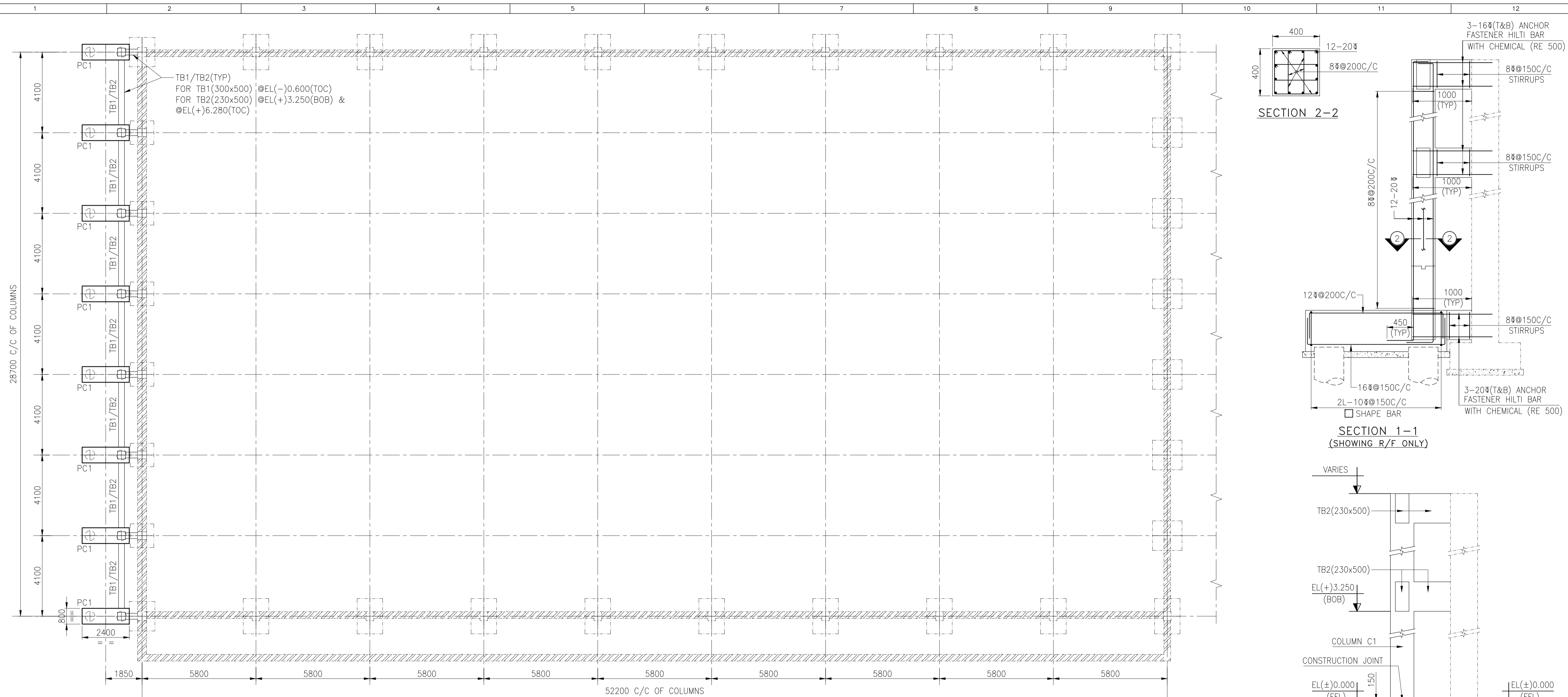

PILE CAP LAYOUT PLAN FOR CENTRAL WAREHOUSE

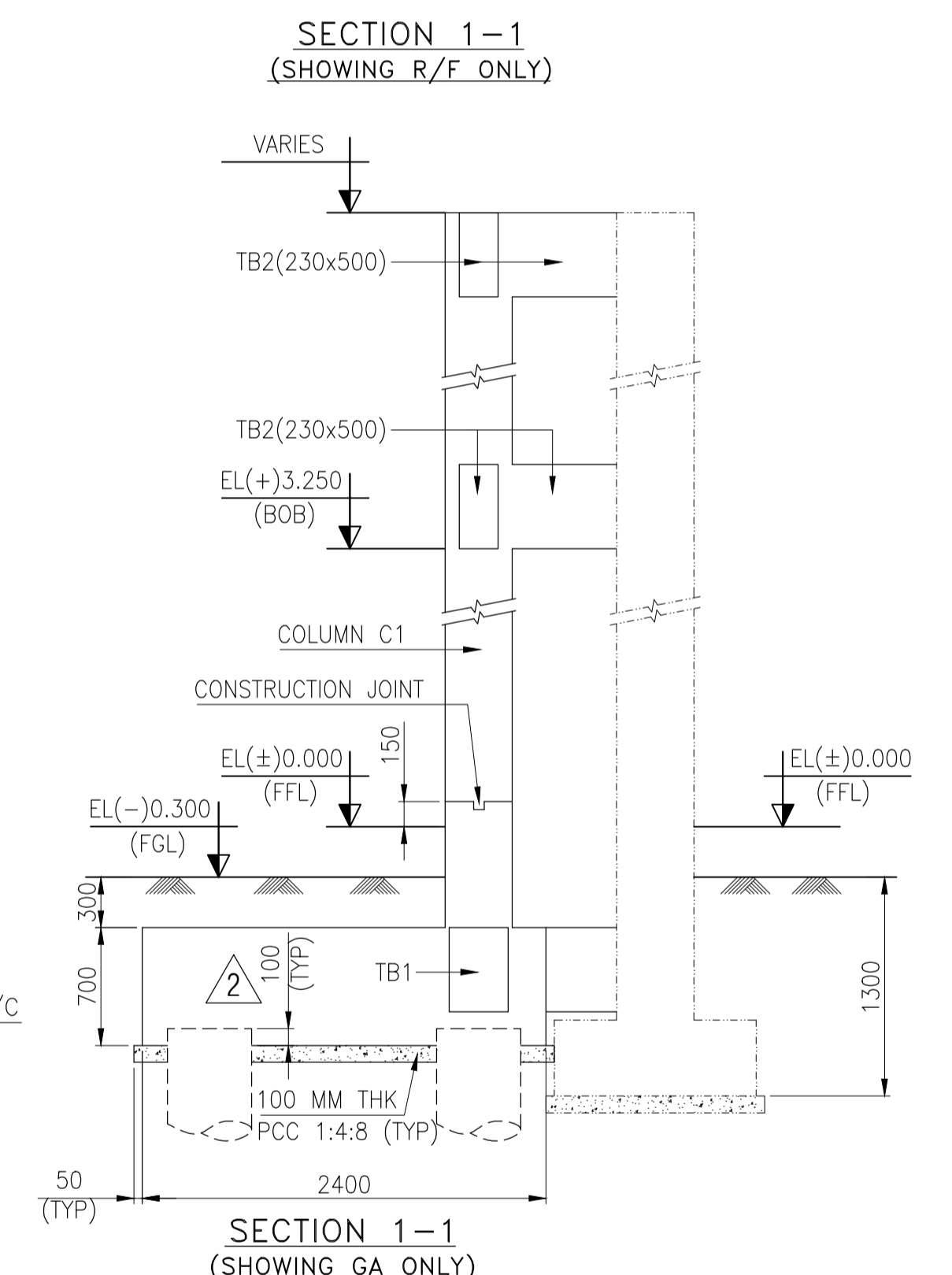
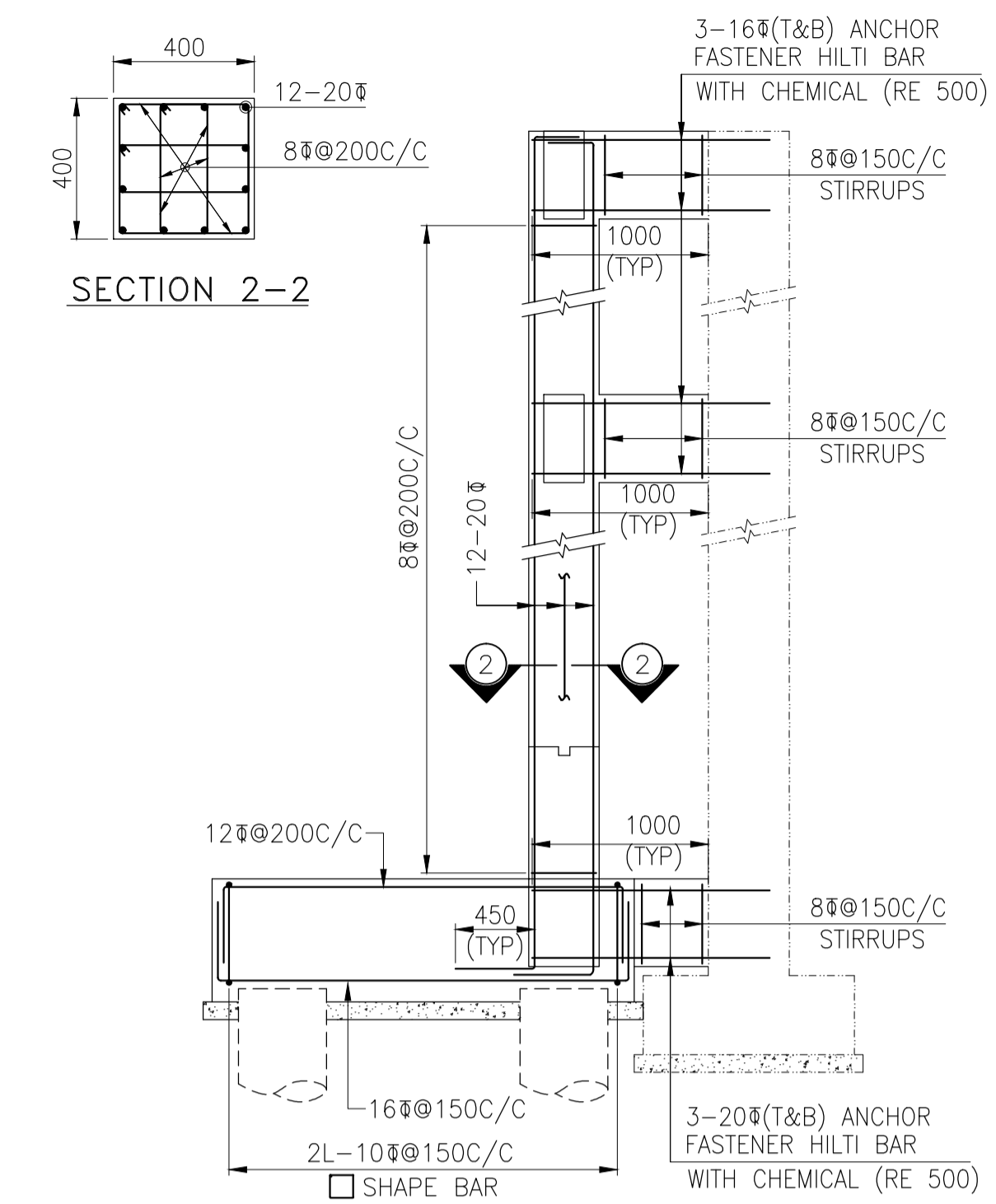

**DESIGN PHILOSOPHY:-**

1. WE PROPOSE TO PROVIDE ADDITIONAL COLUMN IN BETWEEN THE EXISTING COLUMN FLUSHING WITH INNER EXISTING SURFACE OF THE WALL.
2. BOTTOM PLINTH BEAM SHALL BE PROVIDED BETWEEN THESE PROPOSED COLUMNS.
3. NEW WALL SHALL BE ERECTED ON THESE BEAMS WHICH WILL BE SUPPORTED ON THE PROPOSED COLUMN.
4. WE PROPOSE TIE BEAM AT LINTEL LEVEL AND TOP LEVEL INLINE WITH THE NEW COLUMN.
5. AFTER ERECTING THE NEW WALL AND NEW COLUMN DAMAGE WALLS SHALL BE REMOVED.
6. THIS HAS BEEN ISSUED FOR APPROVAL OF PHILOSOPHY AS MENTIONED ABOVE.

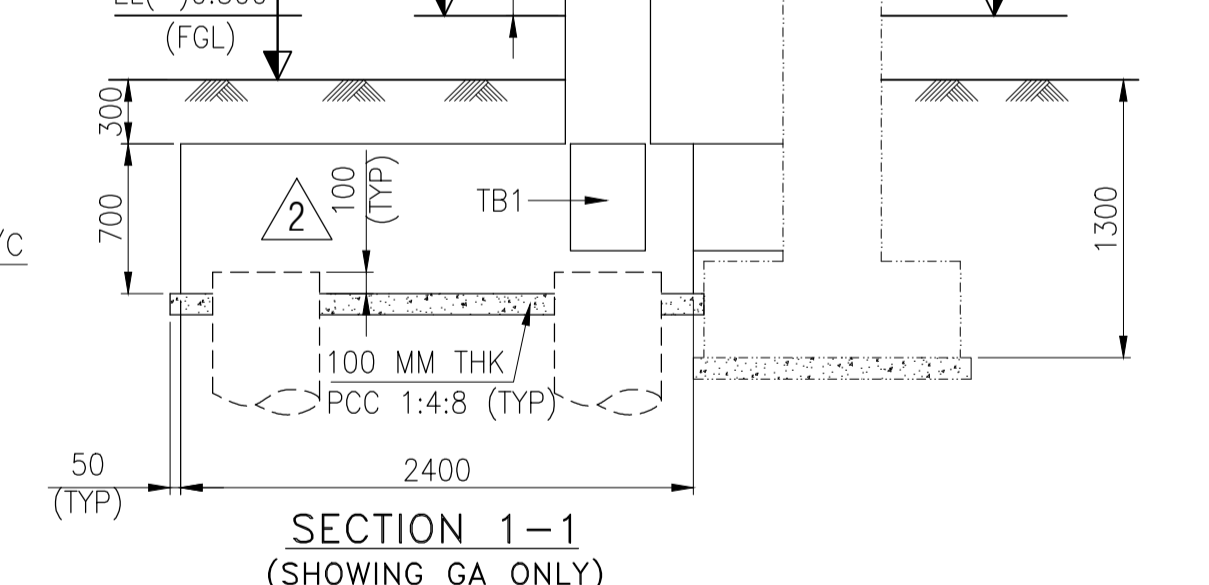
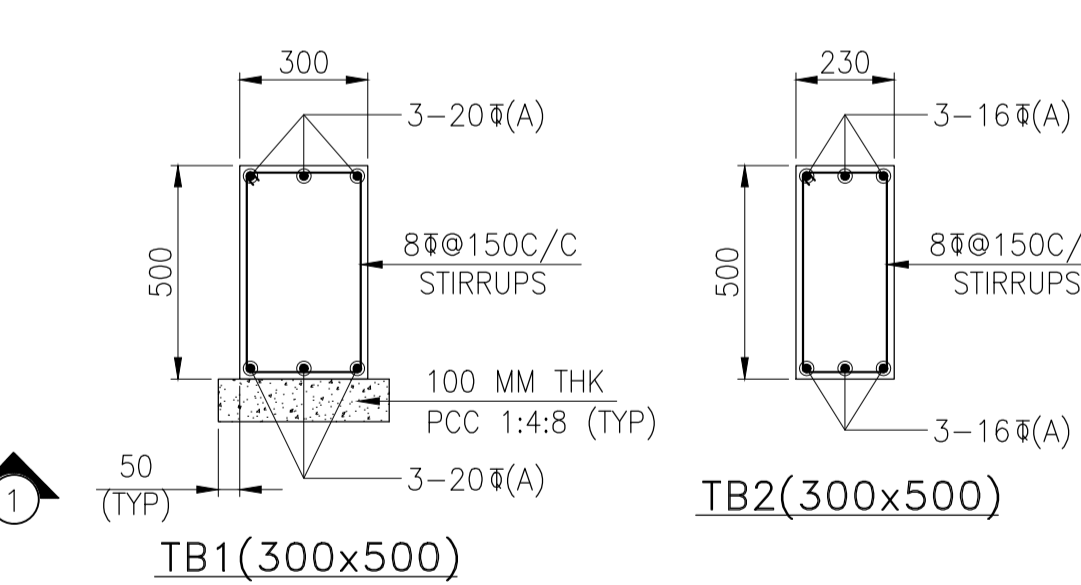
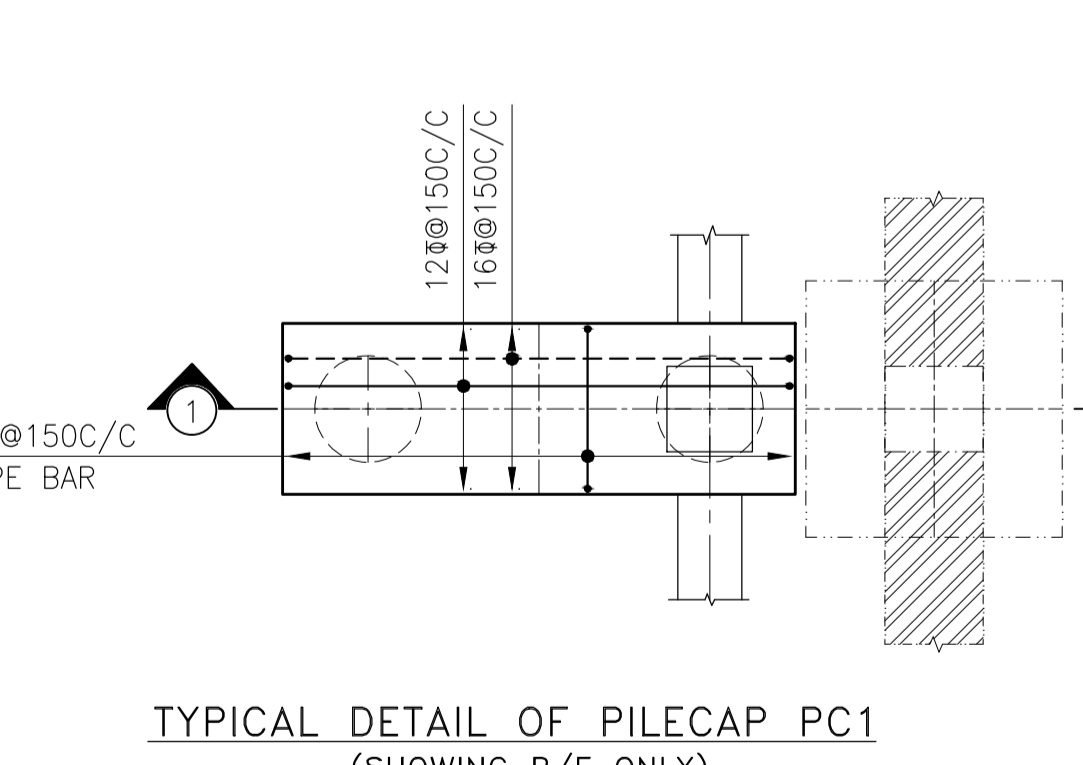
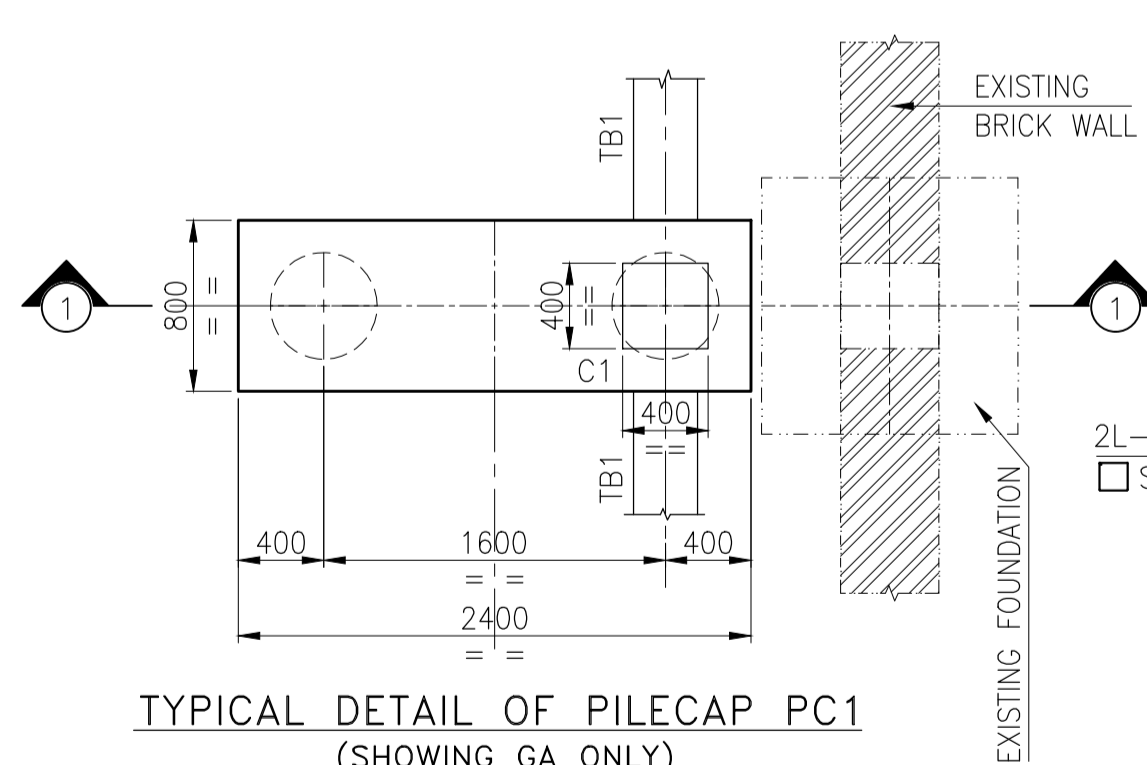

**GENERAL NOTE:-**

1. ALL DIMENSIONS ARE IN MILLIMETERS, CO-ORDINATES & LEVELS IN METERS.
2. GRADE OF RCC FOR 500 Ø SINGLE BULB UNDER REAMED PILES SHALL BE M35 CONFORMING TO IS: 456 AS PER GEO TECH RECOMMENDATION.
3. GRADE OF RCC SHALL BE M25 AS PER IS:456.
4. THE REINFORCEMENT BARS SHALL BE HIGH STRENGTH DEFORMED TMT STEEL GRADE Fe500D CONFORMING TO IS : 1786.
5. CLEAR COVER SHALL BE AS FOLLOWS:
  - a) PILECAP BOTTOM - 100 MM
  - b) PILECAP TOP & SIDE - 50 MM
  - c) COLUMN - 50 MM
  - d) BEAM - 50 MM
6. LAP LENGTH (LD) OF REBARS SHALL BE 50 TIMES OF REBAR DIAMETER REBAR DIAMETER.
7. PILE CASTING SHALL BE DONE AT LEAST 1.0M ABOVE CUT-OFF LEVEL.

8. THE CAPACITY OF PILES AS INDICATED CORRESPONDS TO THE MINIMUM SAFE ALLOWABLE LOAD ON INDIVIDUAL PILE AND SHALL BE CONFIRMED BY LOAD TEST.
9. THIS DWG SHALL BE READ IN CONJUNCTION WITH REFER DWG NO.- CWC/PG/397/1-AC, CWC/PG/280/3-AC & CWC/PG/279/2-AC & 2020-DEPL-PWH-ST-002.

**LEGENDS :-**

PCC - PLAIN CEMENT CONCRETE	TOB - TOP OF BEAM
TOC - TOP OF CONCRETE	BOB - BOTTOM OF BEAM
FFL - FINISHED FLOOR LEVEL	R/F - REINFORCEMENT
FGL - FINISHED GROUND LEVEL	GA - GENERAL ARRANGEMENT
EL - ELEVATION	TOPC - TOP OF PILE CAP
∅ - TOR STEEL	

REV	DATE	PARTICULAR	BY	CHKD	APPD
02	29.10.2020	REVISED AS MARKED	PAWAN	J.A.	M.B.L
01	09.09.2020	REVISED & REISSUED FOR APPROVAL	PAWAN	J.A.	M.B.L
00	11.07.2020	ISSUED FOR APPROVAL	PAWAN	J.A.	M.B.L

C.W.C. ENGINEER	CONSULTANTS	ARCHITECT
PROJECT	LAYOUT PLAN FOR CONTAINER FREIGHT STATION IN E.P.I.P. ZONE WHITE ELD - BANGALORE	
CLIENT:	CENTRAL WAREHOUSING CORPORATION (GOVT. OF INDIA UNDERTAKING)	
TITLE:	28.7M. SINGLE SPAN GODOWN PROPOSED LAYOUT FOR UNDERREAM PILES AND PROPOSED COLUMN LOCATION	
DATE	11.07.20	CONSULTANTS:
BY	PAWAN	DENFAB ENGINEERS PVT. LTD. A2/28 SAFDARJUNG ENCLAVE (N. DELHI)
CHKD	J.A.	
APPD	M.B.L	
SCALE	1: 100	DRG.NO. 2020-DEPL-PWH-ST-001
REV.	02	

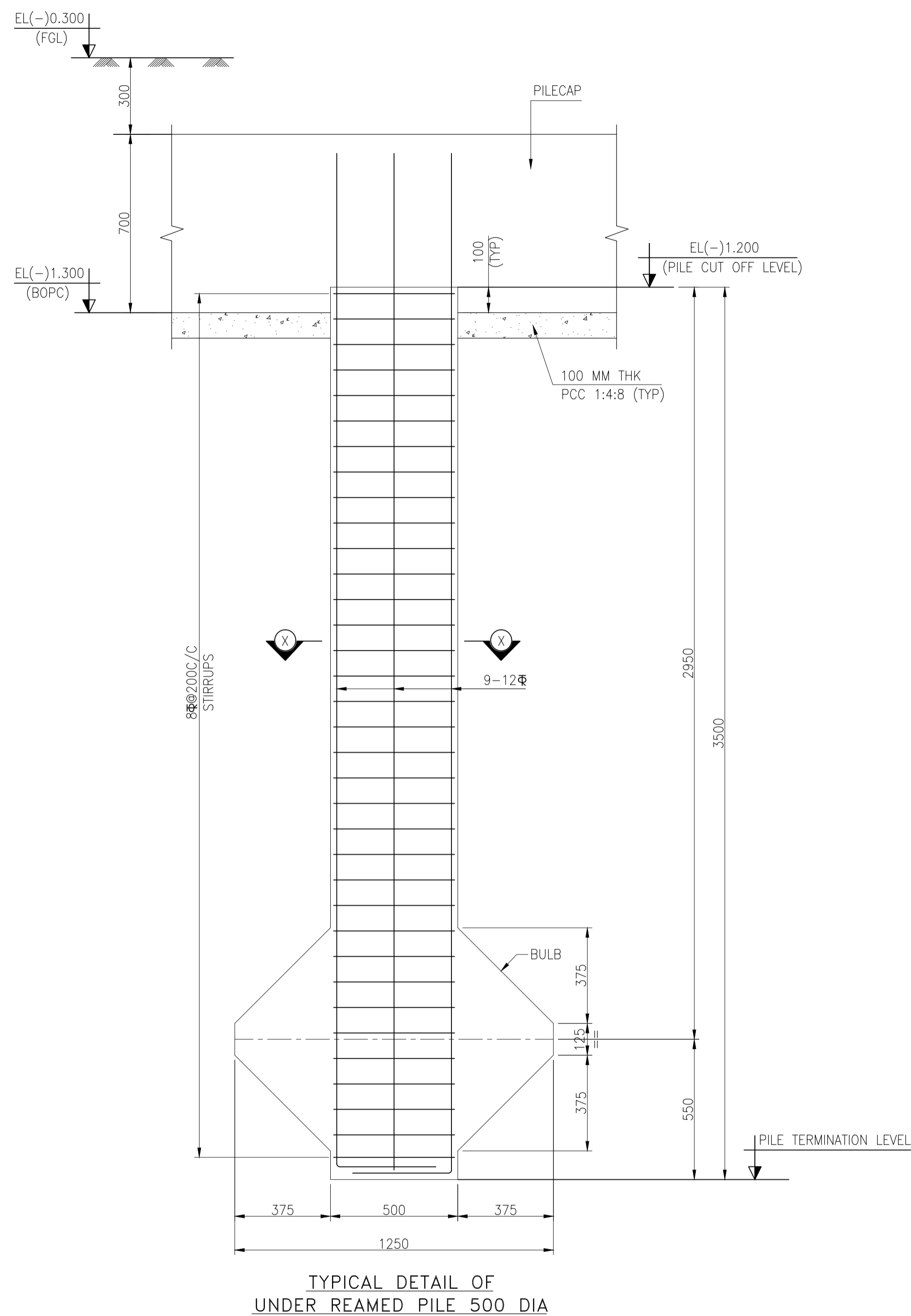

\* REFER NOTE:-4

* SCHEDULE OF SINGLE BULB UNDER REAMED PILE				
S. NOS.	DIA OF PILE	* COMPRESSION (T)	* TENSION (T)	* LATERAL THRUST (T)
1	500 DIA	40	16	3

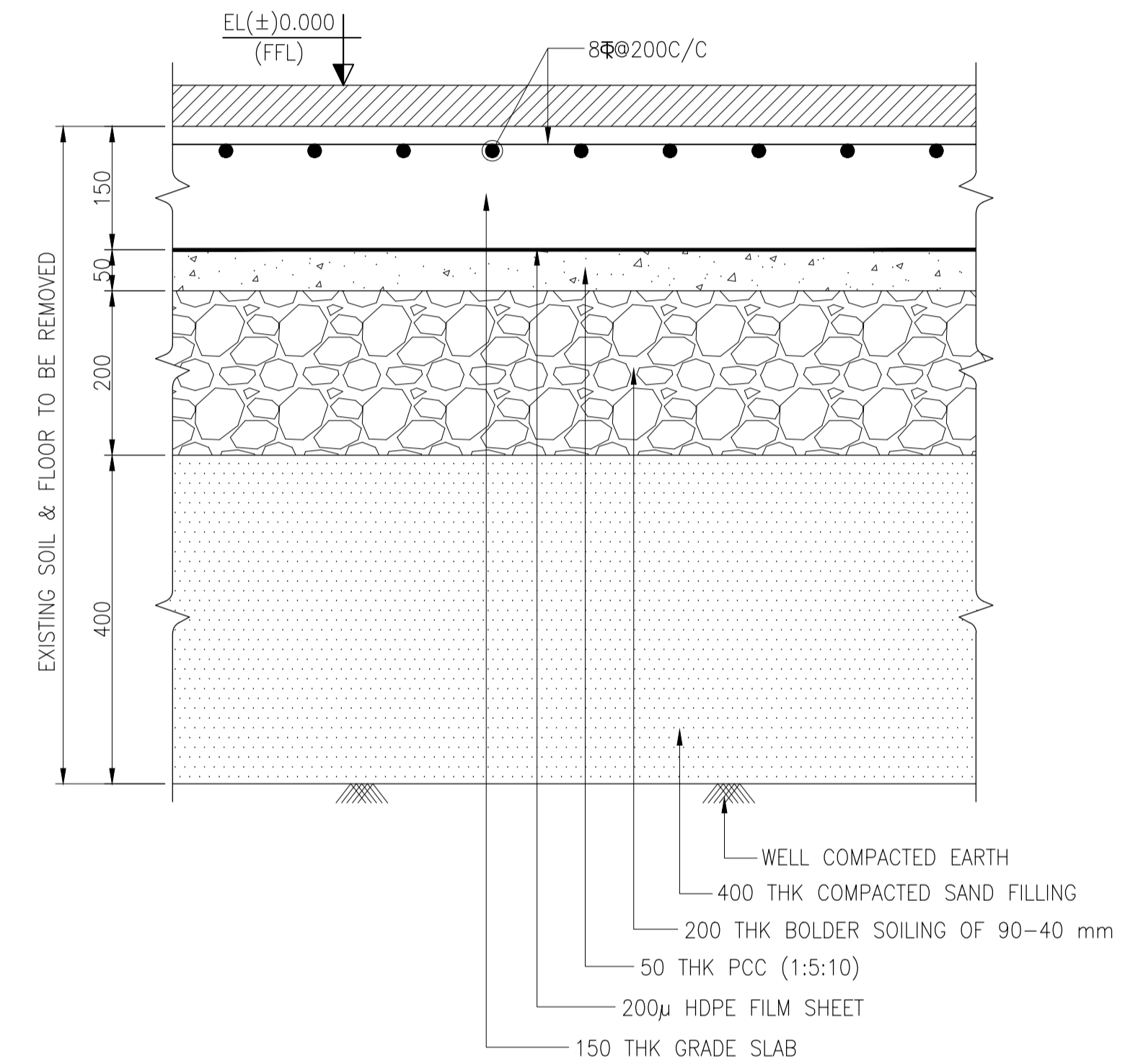
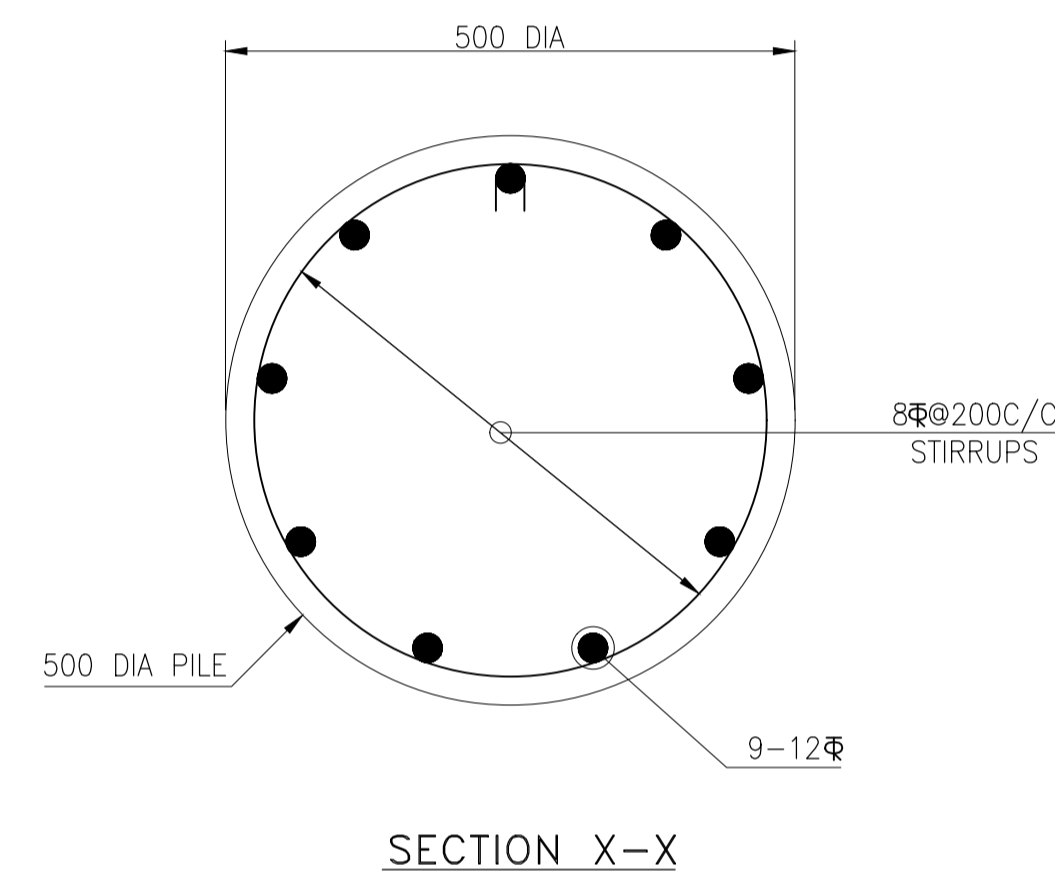

FLOOR OF REBUILT TYPICAL SECTION FOR DAMAGED FLOOR

**GENERAL NOTE:-**

1. ALL DIMENSIONS ARE IN MILLIMETERS, CO-ORDINATES & LEVELS IN METERS.
2. FOR OTHERS NOTES AND LEGENDS REFER DWG NO. 2020-DEPL-PWH-ST-001
3. THIS DWG SHALL BE READ IN CONJUNCTION WITH REFER DWG NO.-2020-DEPL-PWH-ST-001
4. PILE LOAD TEST SHALL BE CARRIED OUT TO VERIFY THE CAPACITY.

REV	DATE	PARTICULAR	BY	CHKD	APPD
00	29.10.2020	ISSUED FOR APPROVAL	PAWAN	J.A.	M.B.L
REVISIONS					

C.W.C. ENGINEER	CONSULTANTS	ARCHITECT			
PROJECT	LAYOUT PLAN FOR CONTAINER FREIGHT STATION IN E.P.I.P. ZONE WHITE ELD - BANGALORE				
CLIENT:	CENTRAL WAREHOUSING CORPORATION (GOVT. OF INDIA UNDERTAKING)				
TITLE:	28.7M. SINGLE SPAN GODOWN UNDERREAM PILES DETAILS AND GRADE SLAB DETAILS				
DATE	29.10.20	CONSULTANTS:			
BY	PAWAN	DENFAB ENGINEERS PVT. LTD. A2/28 SAFDARJUNG ENCLAVE (N. DELHI)			
CHKD	J.A.				
APPD	M.B.L				
SCALE	1: 25	DRG.NO.	2020-DEPL-PWH-ST-002	REV.	00